

ESQUEMAS Y FUNCIONES ELÉCTRICAS

TIPO	ESQUEMA	FUNCION	TIPO	ESQUEMA	FUNCION	FUNCION
...A2U...			...AR...			
...11T...			...K1R...			
...22T...			...K2R...			
...AU...			...11R...			
...A2T...			...22R...			
...AT...						

DIMENSIONES

PEDAL SIN PROTECCIÓN

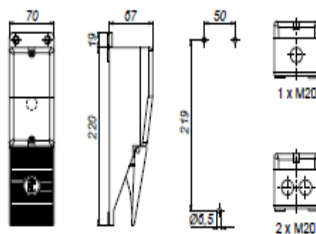

1xM20. TIPOS: FD-11T-G, FP-2,2KLIN-G, FP-4,7KLIN-G, FP-10KLIN-G.
2xM20. TIPOS: FD-A2U-G, FD-2AT-G

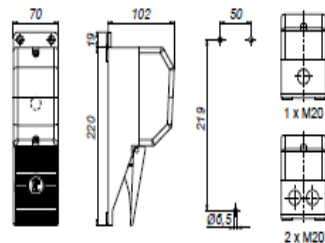

1xM20. TIPO: FD-22T-G
2xM20. TIPOS: FD-AU-G, FD-AT-G

PEDAL CON PROTECCIÓN

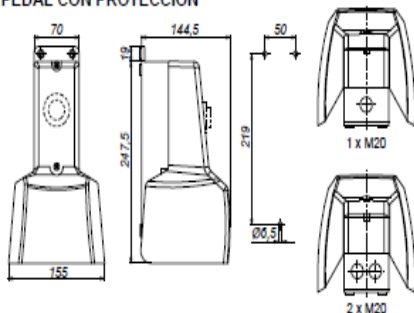

1xM20. TIPOS: FD-11T-GU, FD-22T-GU, FD-K2R-GU
2xM20. TIPOS: FD-A2U-GU, FD-A2T-GU, FD-AU-GU, FD-AT-GU

PEDAL DOBLE CON PROTECCIÓN

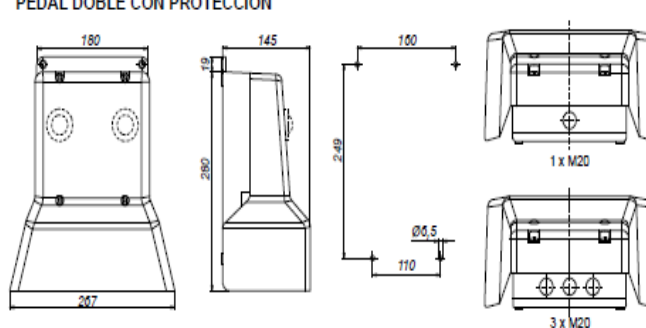

1xM20. TIPOS: FD-11T/11T-GU, FD-22T/22T-GU, FD-K1R/K1R-GU, FD-K2R/K2R-GU, FD-AR/11T-GU.