

MSR42, GuardShield Micro 400 and Safe 2/Safe 4 Light Curtains

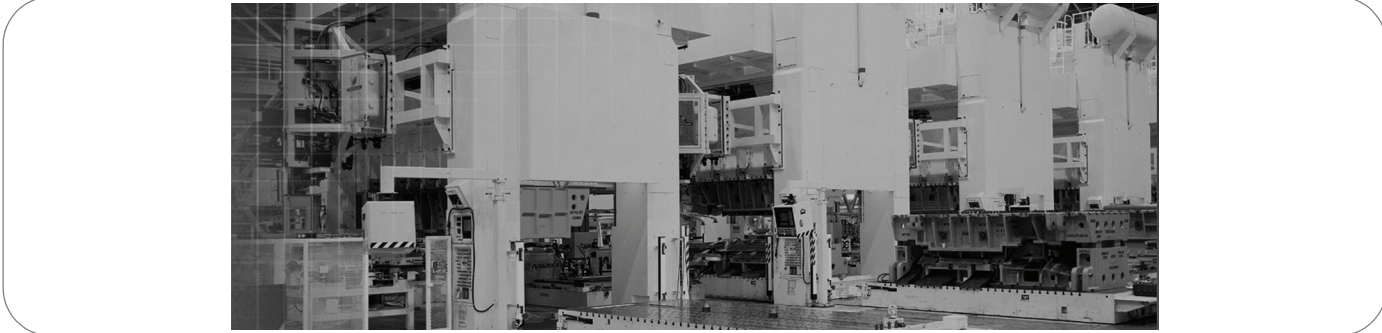

Configuration and Diagnostic Software Tool

User Manual



Important User Information





Because of the variety of uses for the products described in this publication, those responsible for the application and use of this control equipment must satisfy themselves that all necessary steps have been taken to assure that each application and use meets all performance and safety requirements, including any applicable laws, regulations, codes and standards.

The illustrations, charts, sample programs and layout examples shown in the guide are intended solely for purposes of example. Since there are many variables and requirements associated with any particular installation, Rockwell Automation does not assume responsibility or liability (to include intellectual property liability) for actual use based upon the examples shown in this publication.

Rockwell Automation publication SGI-1.1, Safety Guidelines for the Application, Installation and Maintenance of Solid-State Control (available from your local Rockwell Automation sales office), describes some important differences between solid-state equipment and electromechanical devices that should be taken into consideration when applying products such as those described in this publication.

Reproduction of the contents of this copyrighted publication, in whole or part, without written permission of Rockwell Automation, is prohibited.

Throughout this manual we use notes to make you aware of safety considerations:

WARNING 	Identifies information about practices or circumstances that can cause an explosion in a hazardous environment, which may lead to personal injury or death, property damage, or economic loss.
IMPORTANT	Identifies information that is critical for successful application and understanding of the product.
ATTENTION 	Identifies information about practices or circumstances that can lead to personal injury or death, property damage, or economic loss. Attentions help you identify a hazard, avoid a hazard, and recognize the consequences.
SHOCK HAZARD 	Labels may be on or inside the equipment (for example, drive or motor) to alert people that dangerous voltage may be present.
BURN HAZARD 	Labels may be on or inside the equipment (for example, drive or motor) to alert people that surfaces may reach dangerous temperatures.

It is recommended that you save this user manual for future use.

IMPORTANT

These products can only achieve their function as a safety controller module, if the instructions given in this instruction manual and the within mentioned documents are exactly followed, as well as consulting the valid laws and regulations at the time of installation.

Should these instructions not be carefully followed, serious injury or death may occur. The installer or system integrator will be fully responsible for a safe integration of this product. In this case Rockwell Automation, or any other party who may have distributed the software will not be liable for any damages.

The configuration of a GuardShield Micro 400 or Safe 2/4 with the MSR42 controller may only be performed by authorized personnel. The configuration of every controller must correspond to the requirements of the risk analysis for the monitoring of every application. An incorrect, or insufficient configuration may lead to serious injury or even death.

To configure a unit mentioned above, a password and an Optical Interface are necessary. Both of these must only be made available to authorized personnel.

This instruction manual is part of the controller module MSR42, GuardShield Micro 400 and Safe 2/4. It must be kept accessible together with the other machine documentation during its entire life cycle for all personnel responsible for assembly, installation, operation and maintenance.

All details reported by the program are for guidance only. Rockwell Automation does not give any warranty for calculations, general information, prices or technical details about correctness and completeness.

In the interests of continual technical advancement, Rockwell Automation reserve the right to amend the specification of the products and of the prices detailed in this software without prior notice. For further information contact your nearest Rockwell Automation sales office or Allen-Bradley distributor.

This software is provided "as is" without warranty of any kind either expressed or implied, including but not limited to the implied warranties merchantability and fitness for a particular purpose. The entire risk as to the quality and performance of the product is with you. Should the product prove defective, you assume the cost of all necessary servicing or error correction. Rockwell Automation does not warrant that the functions contained in the software will meet your requirements or that the operation of the software will be uninterrupted or error free.

In no event shall Rockwell Automation, or any other party who may have distributed the software as permitted above, be liable for damages, including any general, special, incidental, or consequential damages arising out of the use or inability to use the software (including but not limited to loss of data or data being rendered inaccurate or losses sustained by you or third parties or failure of the software to operate with any other products), even if such holder or other party has been advised of the possibility of such damages.

TÜV Rheinland Product Safety GmbH, has tested the functions and the safety relevant adjustment possibilities of this software, and confirmed the basic correct functioning of all adjustment possibilities.

Remark:

Obviously this program could not be tested with every type of computer or operating system. For that reason every result has to be proved for plausibility. Every calculation of this program is based on standards DIN EN ISO 13855 (2010) and EN 61496-2. Special applications with their specific standards as well as country specific directions are not taken into account. Therefore the user is responsible for the application of this program.

Content

Introduction	2
Special Features	2
Introduction	3
Special Features	3
Installation	3
Preparation	3
Operating Systems	4
Installation Configuration and Diagnostic Software	4
Installation USB driver for Optical Interface	8
Program start	8
Optical Interface	8
Configuration Tool for GuardShield Safe 2/Safe 4 Light Curtains	9
Introduction	9
Safety Distance Calculator	11
Safe 2/Safe 4 Diagnostics	12
Configuration Tool for MSR42	13
Introduction	13
Starting MSR42 Configuration Tool	14
The menu bar	15
Menu “File”	16
Menu “Options”	16
Menu “Help”	18
Main window	18
Tab “Design”	18
Tab “Diagnosis”	21
Tab “Application info”	22
Possible Configurations	24
Micro 400 Light Curtain	25
One Device (2 NC)	27
One or Two Device (OSSDs)	27
Safety override	28
Muting Micro 400	30
Muting other device (OSSDs)	31
Function “EDM” + “Start Release”	31
Function “Stop delay”	32
Download, Verify & Upload	32
PC ⇌ MSR42 (Download)	32
Verify download	35
Configuration Protection	36
MSR42 ⇌ PC (Upload)	38
Muting	38
General	38
Muting lamp	39
Muting sensors	39
Mute dependant override function	39
Sensor output delay function	39
Muting with enable signal	40
Muting disable function	40
Safety light curtain interruption monitoring function	40
Muting time recorder	41
Setup: 2 sensor T-type	41
Setup: four sensor T-type	43

Setup: two sensor L-type	45
Setup: two sensor T-type with enable signal	48
Blanking	51
Teach-in Blanking mode	52
Fixed Blanking mode	52
Floating Blanking mode	53
Combining Blanking modes	54
Indication of Blanking	54
Activating blanking	54
Configuring the Blanking Function	54
Appendix	56
Frequently Asked Questions (FAQ)	56

1. Introduction

The “Configuration and Diagnostic Software” developed by Rockwell Automation is designed for the most varying of applications. It can be used as a truly active work-instrument by technicians, safety experts, maintenance personnel, designers, process controllers as well as purchase managers.

The program is primarily used to configure the Rockwell Automation GuardShield and MSR42 products but can also be used for diagnosis functions together with the “Optical Interface”. The “Configuration and Diagnostic Software” is delivered with every Optical Interface and is also available free of charge, on the Internet at www.ab.com.

This software description manual covers the following Rockwell Automation products:

- Safety Relay MSR42
- Safety Light Curtain Micro 400
- Safety Light Curtain Safe 2
- Safety Light Curtain Safe 4

With the help of this software, functions like start mode (automatic or manual), stop delay, EDM, and “Safety Override” can be chosen easily and configured graphically.

The software provides technical data and various application information of all supported applications.

1.1. Special Features

The features of the Configuration Tool are:

- Simple installation
- Simple graphical user interface
- Easy to use
- No programming knowledge necessary
- Diagnosis tool integrated
- Detailed safety information integrated
- Optical interface communication software included
- Password protected MSR42 configuration
- Enables process control
- Optimize maintenance services
- Light curtain configuration and diagnostics
- Visual indication of terminal assignment
- Safety distance calculation
- Free download at www.ab.com

2. Installation

2.1. Preparation

IMPORTANT

Before connecting the USB optical interface to the computer, the software configuration tool has to be installed (*See chapter 2.3 on page 4*).

During installation the USB driver software is copied to the hard drive. After this the USB Optical Interface can be connected to the computer and the driver software installed (*See chapter 2.3 on page 4*).

Before installation of the newest version of the Configuration and Diagnostic Software, Rockwell Automation recommends that the previous versions be uninstalled. This is carried out using the following link:

Windows-Start — Program — Rockwell Automation applications — Configuration and Diagnostic Software — Additional Configuration and Diagnostic Software — Uninstall Configuration and Diagnostic Software.

Make sure that all programs active in the background on your PC are shut down. These may disturb the correct “Set up” installation of the Configuration and Diagnostic Software.

2.2. Operating Systems

The Configuration and Diagnostic Software works on the following operating systems:

- Windows 2000
- Windows XP SP1, SP2
- Windows Vista

2.3. Installation Configuration and Diagnostic Software

Start installation with the following link

SetupDiagnosticAndConfiguration_V130.exe

The program is available on the Rockwell Automation CD delivered with the the Optical Interface (445L-AF6150). The newest release is also available for free on www.ab.com.

Follow the instructions of the setup program (*Figure 1 ... Figure 9*). This manual refers to proposed settings for the setup program. The blue marked arrows aid to a successful installation of this software.

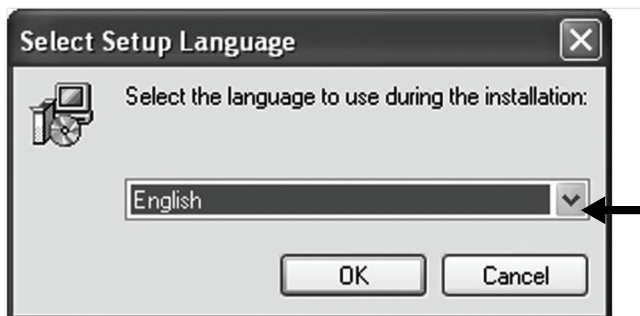

Figure 1: Language selection



Figure 2: Welcome window for installation

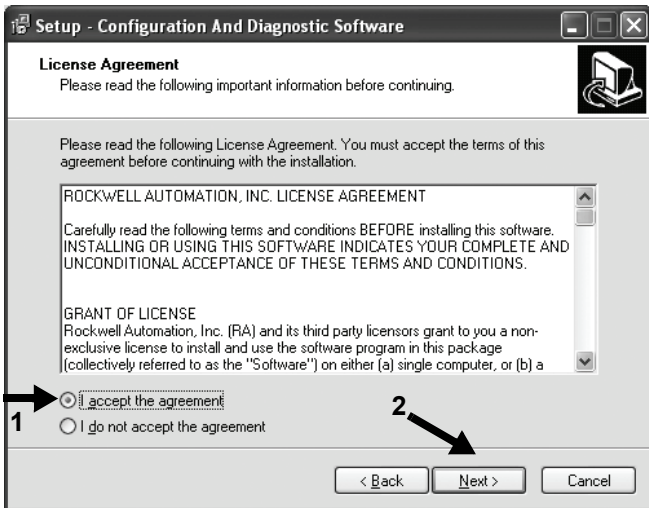

Figure 3: License agreement

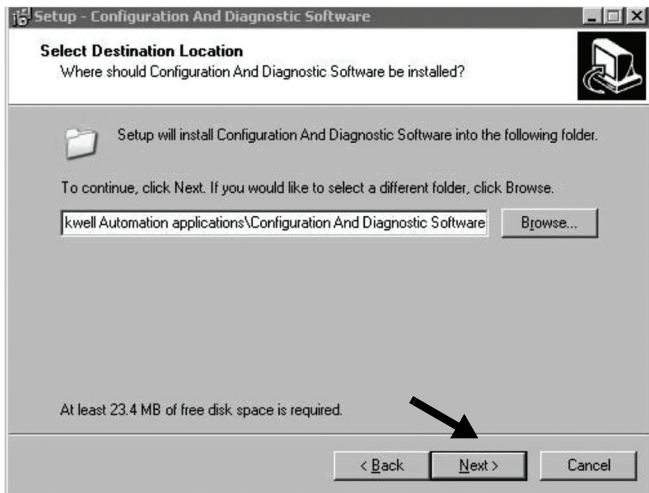

Figure 4: Select target folder of installation. Default: C:\Program Files\RockwellAutomation applications\Configuration and Diagnostic Software

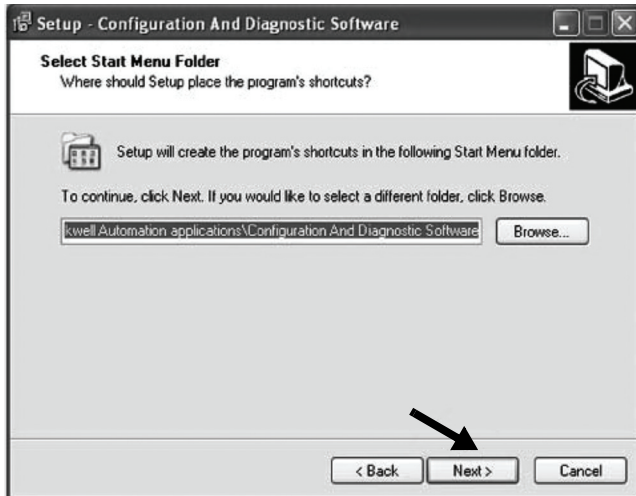

Figure 5: Select the start menu folder

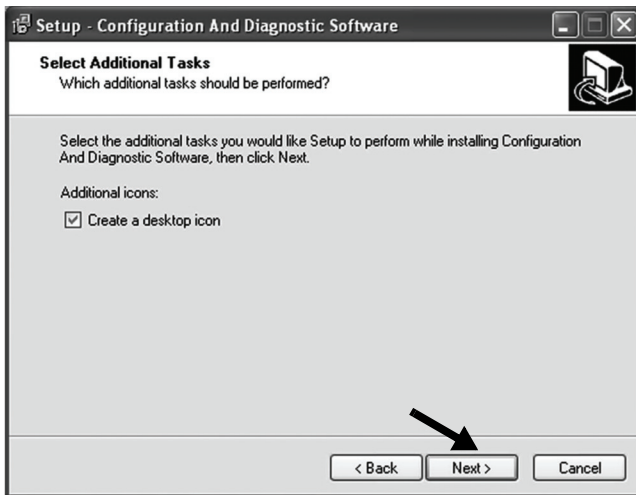

Figure 6: Create desktop symbol

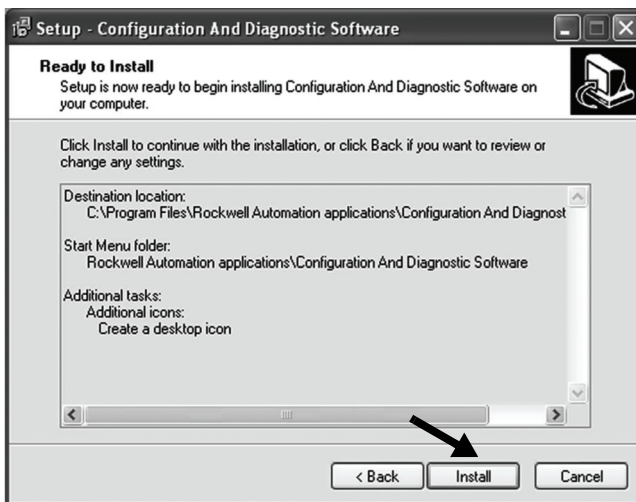

Figure 7: Run installation



Figure 8: Installation finished

ATTENTION



After installation, the authorized user is recommended to immediately enter their user registration information, as well as to change the password. The first time the program starts up, you will be automatically prompted to customize the password and user data. Access to the password, as well as the Optical Interface, must only be permitted for authorized personnel.

2.4. Installation USB driver for Optical Interface

The USB driver is installed automatically during the software installation.

Connect the USB Optical Interface to your computer. The drivers will be automatically loaded once the USB Optical interface is plugged into the available USB port.

2.5. Program start

The Configuration and Diagnostics Software can be started from the desktop icon or the windows start menu.

“Windows-Start” – “Programs” – “Rockwell Automation Applications” – “Configuration and Diagnostic Software” – “Configuration and Diagnostic Software.”

In the Configuration and Diagnostic Software window (*Figure 9*), the following sub programs may be selected:

- GuardShield Safe 2/Safe 4 Safety Light Curtains
- MSR42 Safety Controller

The MSR42 Safety Controller sub program includes configuration and diagnostic functions for GuardShield Micro 400 safety light curtains.



Figure 9: Selection window

First select your preferred language with the pull-down option “Language” in the top right corner of the window. Then select your preferred sub program and the safety warning window appears.

3. Optical Interface

The Optical Interface (Cat. Nr. 445L-AF6150) allows for a fast and easy communication between

- a GuardShield safety light curtain (Safe 2/Safe 4) and a PC or
- a safety controller module (MSR42) and a PC.

The Optical Interface can be used as a diagnosis tool (real time and long term diagnostics) in order to find errors such as insufficient supply voltage, a short circuit of the output, etc.

The Optical Interface can also be used for down- and uploading configurations to a MSR42 controller. The MSR42 and Micro 400 features: blanking, muting, override (and more) may be selected according to customer specific applications and downloaded as described in [chapter 5 on page 13](#).

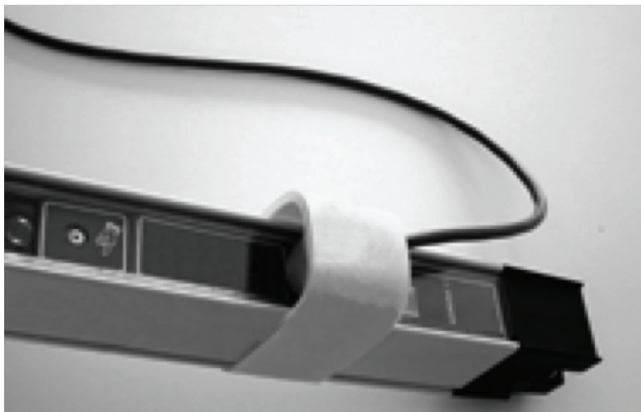

Figure 10: Simple configuration with an Optical Interface

<p>ATTENTION</p>	<p>Access to the password, as well as the Optical Interface must only be permitted for authorized users.</p>
<p>IMPORTANT</p>	<p>Before connecting the USB Optical Interface to the computer the Configuration and Diagnostic Software has to be installed (See chapter 2.3 on page 4).</p>

The connection is simple and completed in seconds:

- Plug the USB connector into an unused USB-port on your computer.
- Press the suction cup of the sensor head onto the marked position. (ⓘ) For a more secure connection, the suction cup may be dampened slightly.
- Interrupt the light curtain (if connected). The communication between the Rockwell device and your computer will be initiated.

4. Configuration Tool for GuardShield Safe 2/Safe 4 Light Curtains

4.1. Introduction

Select the “GuardShield Safe 2/Safe 4” light curtain icon in the selection window (*Figure 9*). A new window will appear (*Figure 11*) with a “warning: read safety information” symbol. Click on this symbol and read the safety warning. Thereafter click “OK” to continue.



Figure 11: GuardShield Safe 2/Safe 4 welcome screen

The “system designer” tab for Safe 2/Safe 4 screen will allow the user to select the light curtain to be used in the application.

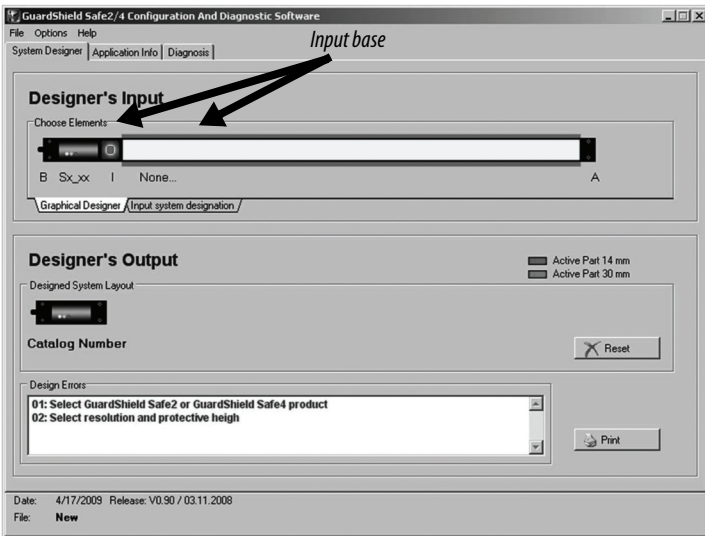

Figure 12: “System Designer”

The “system designer” is split into two sections, a “Designer’s Input” and “Designer’s Output” section. The “Designer’s input” section is used to define a light curtain: pair or transmitter or receiver, as well as the protective field height and resolution. The “Designers Output” section displays the resulting information and catalog number for the configured light curtain.

To configure a light curtain stay in the Graphical Designer tab. Place the mouse cursor on each input base, press the left mouse button and a list will appear with all the available choices for that position.

Upon completion of the configuration selections, the light curtain catalog number, safety category, response time, height/resolution and operating range information will be displayed in the “Designer’s Output” section.

To design a new configuration, press the “Reset” button. To print the configuration, press the “Print” button.

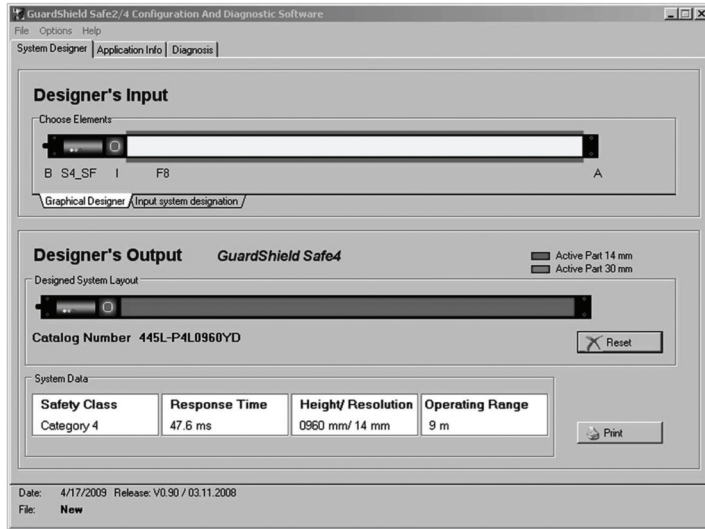

Figure 13: Configured Safe 4 Light Curtain example

4.2. Safety Distance Calculator

Select the “Application Info” tab to display the minimal safety distance calculation section.

The display is usable for the GuardShield Safe 2/Safe 4 light curtains. For applications with the GuardShield Micro 400 Light Curtains, use the MSR42 safety controller sub program.

The “Application Info” is used to calculate the safety distances according to international standards. Results can be printed out and be implemented as part of the customers documentation package.

This display window calculates the safety distances for applications with vertical mounting according to the European standards DIN EN 13855-2010 and EN 61496-1, -2.

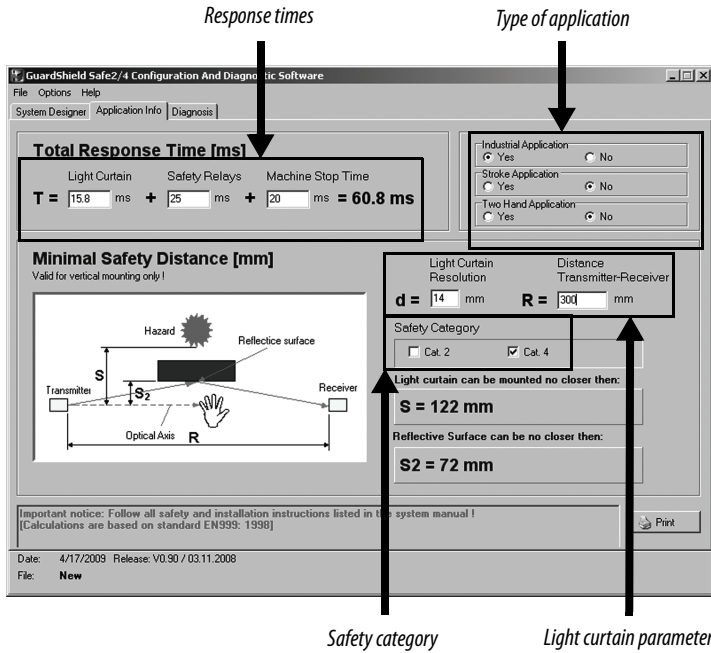

Figure 14: Safety distance calculator

To calculate the minimal safety distance, first answer the three application questions below:

A “Industrial Application; Yes or No”

Choose “Yes” if the application is industrial. Select “No” if the application is not industrial (this means that children also have access to the application).

B “Stroke Application; Yes or No”

Choose “Yes” if the application starts automatically after a preset number of interruptions of the protective field occurs (e.g. presses). Select “No” if the application is not a stroke application.

C “Two Hand Application; Yes or No”

Choose “Yes” if the application is started with two hand control buttons. Choose “No” if not.

Then enter the response time information requested. This data will provide a total response time in milliseconds. Next enter the light curtain parameter data, and the safety category data.

Once all the data has been entered the window will display the minimal light curtain mounting distance and the minimal reflective surface distance data shown in [Figure 15](#).

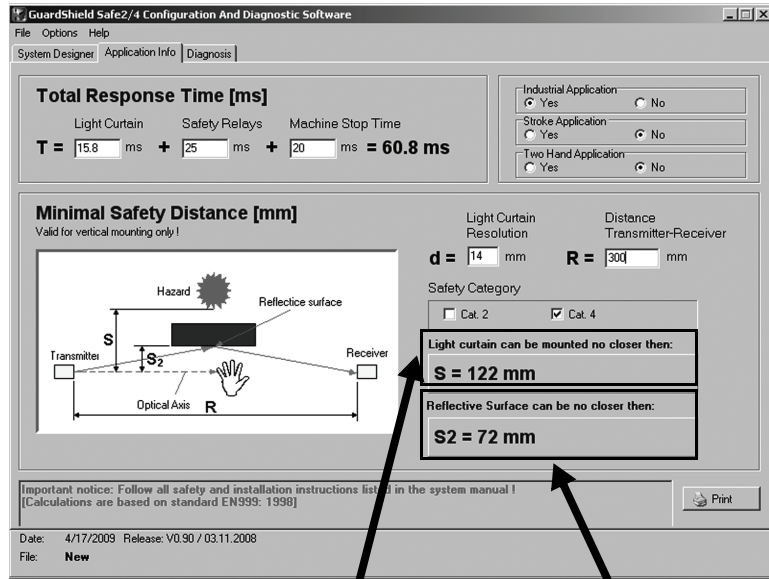

Distance between light curtain pair Minimum reflective surface distance

Figure 15: Safety distance example

4.3. Safe 2/Safe 4 Diagnostics

Select the “diagnosis” tab in the Safe 2/Safe 4 configuration window.

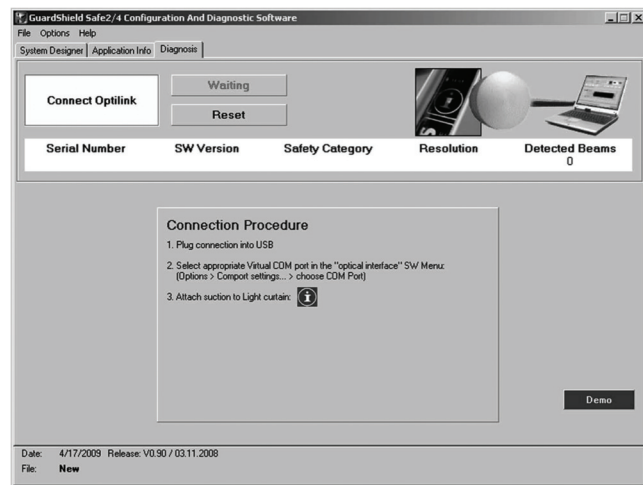

Figure 16: “Diagnosis” tab

Connect the Optical Interface to your PC via the USB connector and attach the suction cup to the receiver of your Safe 2 or Safe 4 Light Curtain. The software establishes a communication after interrupting the protective field.

The software will detect the light curtain and monitor where the light curtain protective field is interrupted. The protective field viewer (Figure 17) displays the lowest and highest interrupted beams. Charting options are available to determine a pattern of which beams are interrupted vs. time (History tab).

In this example showing that beams 15 through 40 were interrupted by an object. As only the highest and lowest interrupted beam information is transmitted, nothing can be said with regards to the status of beams 16 to 39.

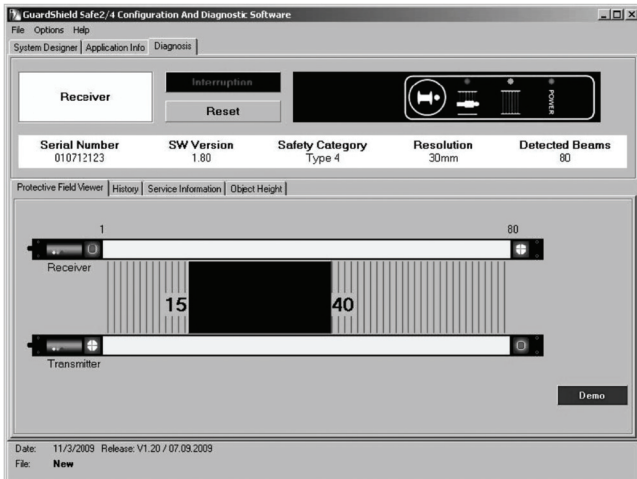

Figure 17: Safe 4 Diagnostics – Object blocking beams

The “History” tab will allow the interrupted beams to be charted versus time.

The “Service information” tab gives additional information for service / maintenance cases.

The “Object height” tab gives information with regards to the height of objects which have interrupted the light curtain.

5. Configuration Tool for MSR42

5.1. Introduction

The “MSR42” sub program of the Configuration and Diagnostic Software Tool is used to configure and diagnose MSR42 safety controllers as well as the connected GuardShield Micro 400 safety light curtain..



Figure 18: MSR42 can be configured to monitor various safety components

MSR42 safety controllers are supplied from the factory with a basic configuration. This basic configuration will satisfy the requirements of many typical GuardShield Micro 400 safety light curtains on/off applications with no configuration necessary. See the MSR42 user manual for more details. To satisfy more advanced applications the MSR42 Configuration tool and an Optical Interface make it easy for authorized personnel to configure the MSR42 for integrated operation with other safety devices such as E-Stops, safety interlocks, additional OSSD devices, or functions such as EDM, safety override, blanking or muting.

A customer specific configuration has to be downloaded to the MSR42 safety controller. It is carried out with the Optical Interface ([See chapter 3 on page 8](#)).

5.2. Starting MSR42 Configuration Tool

The Configuration Tool starts with the selection window ([Figure 9](#)). First select your preferred language with the pull-down option “language”. Then select the MSR42 icon and the welcome window for this product appears ([Figure 19](#)).

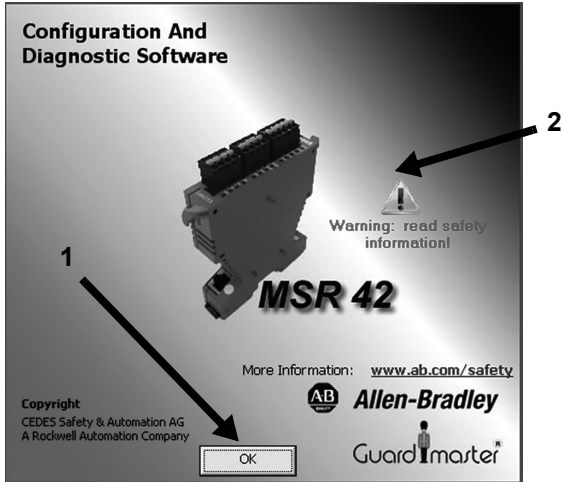

Figure 19: “Welcome window” for MSR42.

A “Warning: read safety information” symbol is shown on this welcome window. Click on this warning symbol (2) and read this safety information. By clicking on the “OK” Button (1) you accept this safety information, and the program will start.

ATTENTION	After installation, the authorized user is prompted to immediately enter their user registration information, as well as to change the password if desired. See Menu 'Options'
ATTENTION	Access to the password, as well as the Optical Interface must only be permitted for authorized users.

The MSR42 configuration window will appear ([Figure 20](#)). This window contains the menu bar (#1), as well as the following three main tabs (#2):

- Design
- Diagnosis
- Application Info

Each of these main tabs may be divided into further sub-tabs (#3).

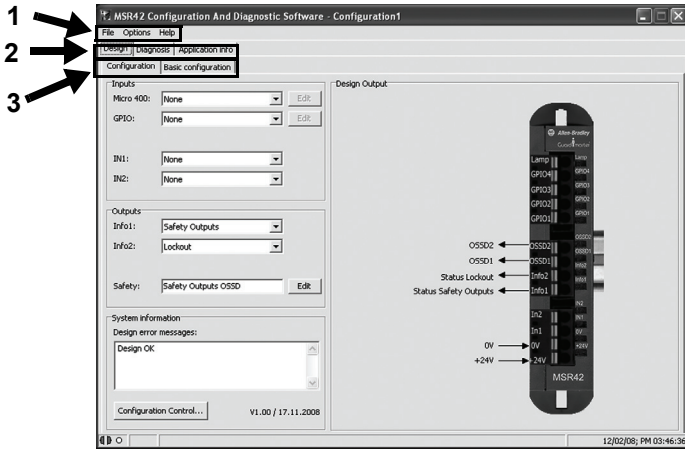

Figure 20: Main window with menu bar (1) and main tabs (2) as well as sub-tabs (3)

5.3. The menu bar

The menu bar contains three pull-down menus:

1. File
2. Options
3. Help

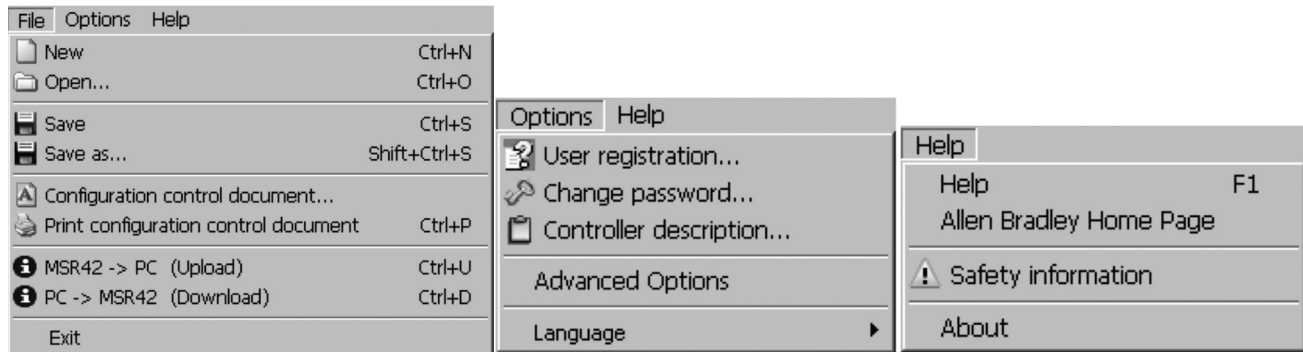

Figure 21: Items in the Menu bar

5.3.1. Menu "File"

Menu "New"

Create a new configuration.

Menu "Open"

Opens an existing configuration file according to the given String and Data name. ".cfg" is defined as the standard extension for the configuration data name.

Menu "Save"

Saves the current configuration under the most recent name and location.

Menu "Save as"

Saves the current configuration under a new name and given location.

Menu “Configuration control document”

Displays the current configuration control document on screen.

Menu “Print configuration control document”

Prints a Configuration Control Document with the current configuration.

Menu “MSR42 ⇌ PC (Upload)”

Uploads the current MSR42 control unit configuration into the PC (*See chapter 5.5.4 on page 37*).

Menu “PC ⇌ MSR42 (Download)”

Downloads the current configuration from the PC, into the MSR42 control unit (*See chapter 5.5.1 on page 31*).

Menu “Exit”

Ends the “MSR42 Configuration Tool” program.

5.3.2. Menu “Options”

5.3.2.1. Menu “User registration”

This menu button opens the “User registration” window (*Figure 22*). This information is required before a configuration download is allowed.

Data entered in the “User registration” fields will be used to complete the information printed on the Configuration control document (*Figure 51*). This information be only entered once, as it is saved in the PC.

The screenshot shows a standard Windows-style dialog box titled "Configuration And Diagnostic Software Properties". The active tab is "Change password". On the left side of the dialog, there is a graphic of an open envelope. To the right of the graphic are several text input fields for user registration information. The fields are: "Company *" (with an asterisk indicating it's required), "First name *" (with an asterisk), "Last name *" (with an asterisk), "Address", "Zip", "City", "Country", "Phone", "Fax", and "E-Mail". Below these fields, there is a note: "* Required Informations". At the bottom right of the dialog, there are two buttons: "OK" and "Cancel".

Figure 22: User registration

5.3.2.2. Menu “Change password”

This menu (*Figure 23*) allows the existing download “ABGM” (capital letters) password to be changed. The password as well as the Optical Interface should only be made available to authorized personnel who are permitted to change configurations. When installing the software, care should be taken to change the standard password “ABGM” (capital letters!) as soon as possible so that any possibility of unauthorized usage can be eliminated. A lost password can be recovered by contacting Rockwell Automation/Allen-Bradley Technical Support.

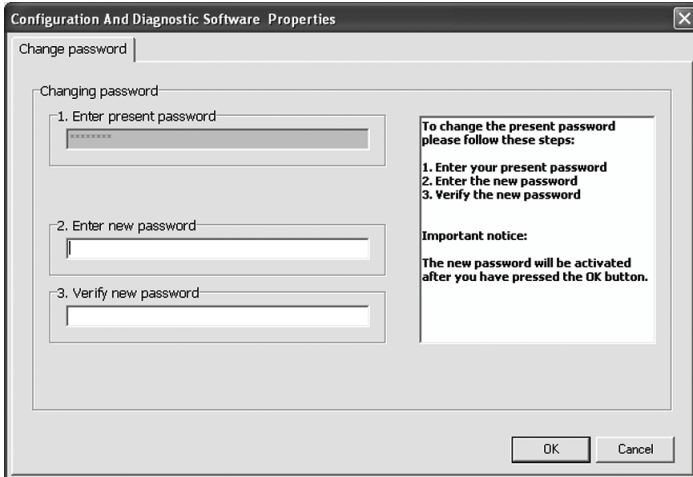

Figure 23: Change password

5.3.2.3. Menu "Controller Description"

The device number can be entered here or when downloading a configuration to a MSR42 controller (*See chapter 5.5.1 on page 31*).

The field "Designation" can be used to name the configuration (*Figure 24*). This name will be printed on the configuration document (*Figure 51*). This name makes it easier to identify the configuration in the future.

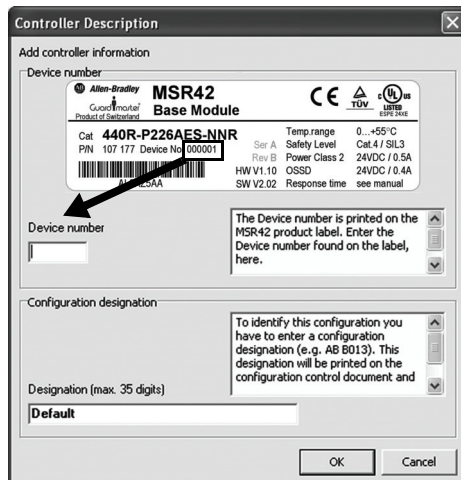

Figure 24: Controller description

5.3.2.4. Menu "Advanced Options"

This menu button is only intended for service / maintenance cases.

5.3.2.5. Menu "Language"

Here the preferred language maybe selected.

5.3.3. Menu "Help"

5.3.3.1. Menu "Help"

Opens this user manual in a separate window as a PDF-file.

5.3.3.2. Menu "Allen Bradley Home Page"

Opens the the Allen-Bradley homepage in your Internet-Browser.

5.3.3.3. Menu “Safety information”

Gives important safety information for installing and operating the software.

5.3.3.4. Menu “About”

Displays the welcome window to check software version.

5.4. Main window

Three main tabs are available to choose from (*Figure 20*):

1. Design (*See chapter 5.4.1 on page 18*)
2. Diagnosis (*See chapter 5.4.2 on page 21*)
3. Application info (*See chapter 5.4.3 on page 22*)

5.4.1. Tab “Design”

In the design window two sub-tabs are available (1, *Figure 25*):

1. Configuration (*See chapter 5.4.1.1 on page 18*)
2. Basic configuration (*See chapter 5.4.1.2 on page 20*)

5.4.1.1. Configuration

This tab offers the possibility to specify the type and the properties of the safety components that can be controlled. By clicking on the pull-down windows in the area “Inputs” (2, *Figure 25*) the following options may be selected:

A Micro 400

- None
An MSR42 control unit can also be used for safety functions without a Micro 400 safety light curtain (for example E-Stop, Door-Switch, overriding of a safety device, muting of a safety device, time delay.)
- Micro 400 light curtain

B GPIO (General Purpose Input / Output)

Which signal is connected to the GPIO1 to GPIO4 pins.

- None
- 1 Device (2NC)
- 1 Device (OSSDs)
- 2 Device (OSSDs)
- Override Micro 400
- Override 1 Device (OSSD)
- Muting Micro 400
- Muting other devices (OSSD)

C Input IN1

Which signal is connected to the input IN1

- Test Input
- Start
- None

D Input IN2

Which signal is connected to the input IN2

- Start
- EDM
- Start Release
- None

Detailed information on the various configurations are given in [chapter 5.4.4 on page 23](#)

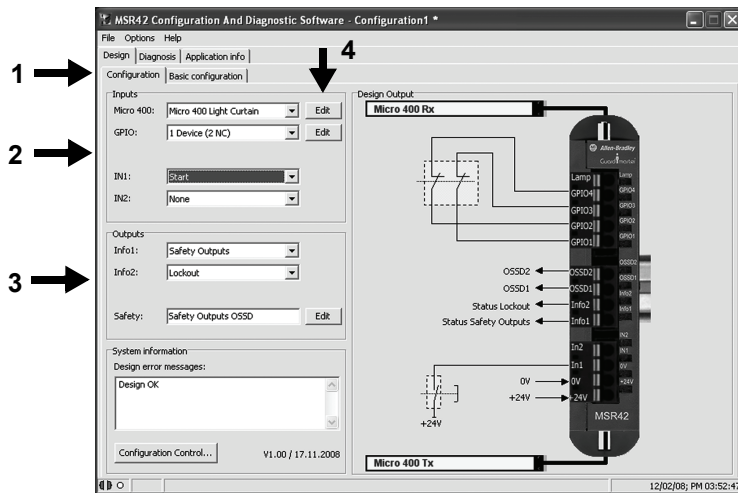

Figure 25: Configuration window

After selecting a component or a function, an individual specification window will pop up to allow further setting adjustments. Adjustments at a later point in time may also be made by clicking on the “Edit” button (4, [Figure 25](#)).

All specification windows are set up similarly. They show the connection terminals, give important safety information, and allow the user to change all important configuration data.

After configuring the Input data the “Design Output” area shows graphically how the safety component must be connected to the control unit ([Figure 25](#)).

If an exclamation symbol is displayed to the left of the OSSD outputs in the “Design Output” area, a stop delay has been activated for at least one of the safety components. Details will be shown on the configuration control document ([Figure 5L](#))

By clicking on the pull-down windows in the “Outputs” section (3, [Figure 25](#)) the following options may be selected:

A Info 1

The MSR42 terminal Info 1 can be allocated to any of the following signals.

- Safety Outputs
- Micro 400 Light Curtain
- Safety Component (GPIO)
- EDM or Start Release
- Lockout
- Low Light Intensity (Micro 400)
- Muting (Automatic)
- Safety Override

ATTENTION



The info output is status information only.
The output may not be used as a safety signal!

B Info 2

The MSR42 terminal Info 2 can be allocated to any of the following signals.

- Safety Outputs
- Micro 400 Light Curtain
- Safety Component (GPIO)
- EDM or Start Release
- Lockout

- Low Light Intensity (Micro 400)
- Muting (Automatic)
- Safety Override

ATTENTION



The info output is status information only.
The output may not be used as a safety signal!

C Safety Outputs OSSD

Using the Edit button the following parameters may be selected.

- Stop delay
- External Device Monitoring

In the lower portion of the Configuration window is a “System information” field, which gives information about design errors.

By selecting the “Configuration Control” button the corresponding configuration control document will appear in a new window (*Figure 26*).

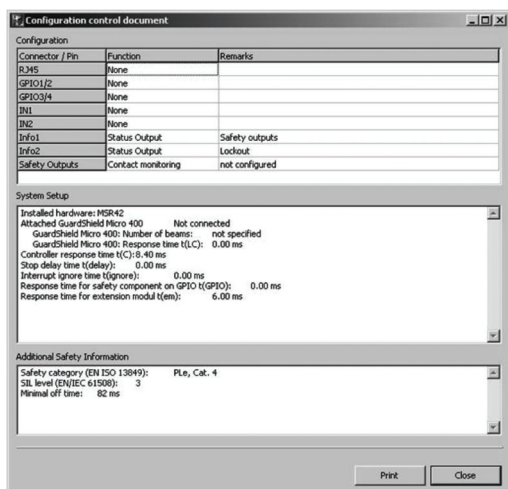

Figure 26: Configuration control document window

5.4.1.2. Basic Configuration

MSR42 (Cat. # 440R-P226AGS-NNR) control units are delivered standard with the “Basic configuration”. The characteristic of this “Basic configuration” is described in the MSR42 user manual and is shown in the sub-tab “Basic configuration” (*Figure 27*).

To set a MSR42 control unit back to the original “Basic configuration” just open the basic configuration sub-tab (*Figure 27*), press “Download Default Configuration” and follow the instructions to download these parameters (*See chapter 5.5.1 on page 31*).

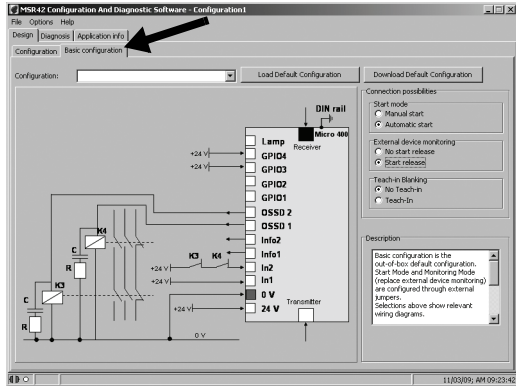

Figure 27: Basic configuration

In this window eight different wiring options of the “Basic configuration” can be displayed. These options can be realized just by wiring any standard, out of the box MSR42 control unit (Cat. # 440R-P226AGS-NNR). No additional configuration is necessary.

5.4.2. Tab “Diagnosis”

In order to carry out a diagnostic of a MSR42 control unit, the following steps must be made:

1. Connect the Optical Interface (See chapter 3 on page 8), to the PC and the MSR42
1. Start the MSR42 “Configuration and diagnostic Software” Tool
3. Select the “Diagnosis” tab (1, Figure 28)

The program immediately detects the MSR42 and displays the transmitted data. Three different functions may be selected (2, Figure 28):

- Protective field viewer
- Service information
- Muting time recorder

Switch between these functions by choosing the corresponding sub-tab.

5.4.2.1. Protective field viewer

This function graphically shows the interrupted area of the GuardShield Micro 400 light curtain protective field (Figure 28). The numbers displayed in this window represent the first and the last interrupted beams. No definite statement can be made with regards to the status of the beams between these two beams, since this information is not transmitted to the MSR42 Configuration and Diagnostic Software.

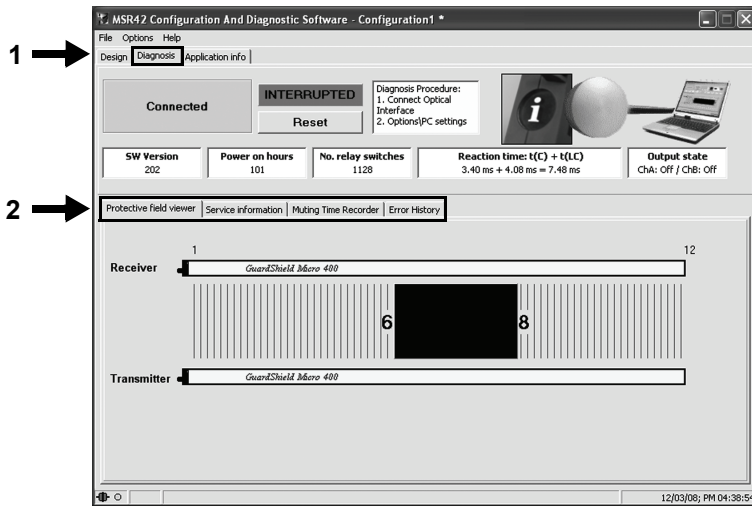

Figure 28: Example of a protective field interruption

5.4.2.2. Service information

For diagnosis of a MSR42 control unit, a short description of the error type may be found in the “Service Information” window (*Figure 29*). External and internal errors, as well as necessary corrective actions, will be displayed here.

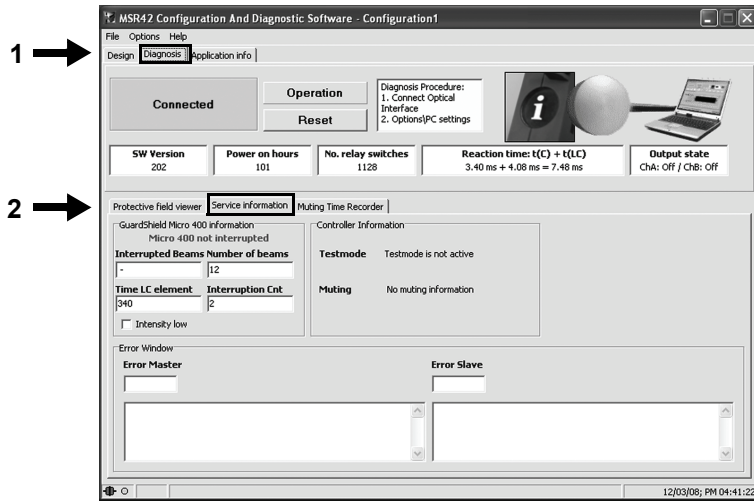

Figure 29: Service information

5.4.3. Tab “Application info”

This window calculates the minimum safety distances for applications with vertically mounted GuardShield Micro 400 light curtains. The corresponding calculations are carried out according to EN ISO 13855-2010 and EN 61496-1, -2. These results can be printed and included as part of the complete risk analysis documentation.

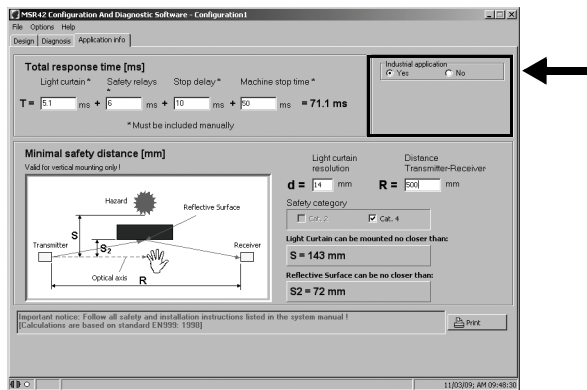

Figure 30: Application information

To calculate the minimal safety distance first answer the following applications question:

“Industrial Application; Yes or No”

Choose “Yes” if the application is industrial. Select “No” if the application is not industrial (this means that children also have access to the application).

Next, the following information must be entered in order to start the calculations of the minimum safety distances (*Figure 31*). These values will be shown on the corresponding configuration control document (*Figure 51*).

- The response time of the GuardShield Micro 400 light curtain [t(LC)]. (See label or if specified see configuration control document).
- The response time for the MSR42 control unit [t(C)].
- The configured stop delay for the safety output [t(delay)].
- If used the reaction time of the MSR45E expander module [t(em)].

The machine stop time must also be entered. This “time” must consider the total length of time, from the moment the MSR45E expander relay contacts open (or when the OSSD outputs change from high to low), until the machine stops. The momentum of the machine, for example, must also be taken into consideration when calculating this stopping time.

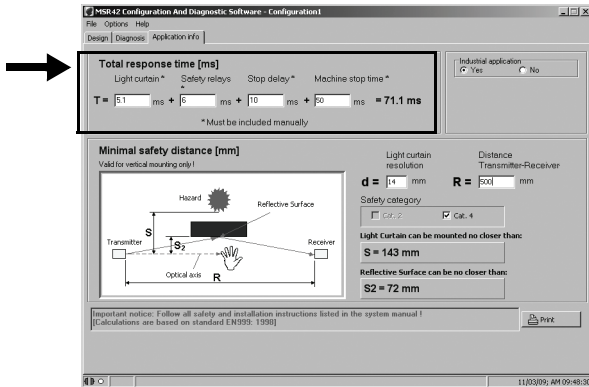

Figure 31: Calculation of the total response time

The default value for the MSR42 control unit response time t(C) is given on the configuration control document.

For information regarding the response time of a GuardShield Micro 400 safety light curtain t(LC), see the light curtain label. If the Micro 400 is defined in the “Configuration and diagnostic software tool” (Figure 33) then the exact time is given in the configuration control document (Figure 51).

To complete the minimum safety distance calculations, the following data must also be entered (Figure 32):

1. Light curtain resolution
2. Distance between transmitter and receiver
3. Safety category

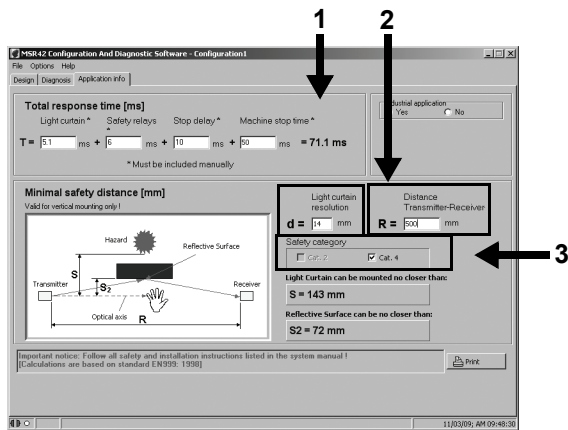

Figure 32: Resolution, distance and safety category

If all the data is entered, the following results will be displayed:

- The minimum safety distance between the protective field and the danger point (S [mm]), for vertical mounting.
- The minimum safety distance to a reflective surface (S2 [mm])

Notice:

Consult the MSR42 user manual, for additional information regarding these calculations. An example of a completed application is shown above.

To see the formulas used to calculate the safety distances, simply position the cursor over the corresponding result. After a short period of time, the corresponding formula will be displayed (Figure 32).

5.4.4. Possible Configurations

Currently, the following safety components and special functions are available (2, Figure 25):

Chapter	Function	Page
5.4.5	Micro 400 Light Curtain	35
5.4.5.1	Blanking	36
5.4.5.2	Interrupt Ignore Time	37
5.4.5.3	Double Scan Filter	38
5.4.6	One Device (2 NC)	39
5.4.7	One or Two Device (OSSDs)	39
5.4.8	Safety override	40
5.4.8.1	Override Micro 400 Safety light curtain	41
5.4.8.2	Override One Device (OSSD)	42
5.4.9	Muting Micro 400	43
5.4.10	Muting other device (OSSDs)	44

Generally the individual specification windows for the safety components are structured the same way: should a stop delay be active and what kind of start mode should be activated.

Detailed settings or functions can be done in the individual specification windows. These windows pop up after selecting the function or at a later point in time by clicking on the “Edit” button (4, [Figure 25](#)).

Furthermore under “Safety Outputs OSSD” the functions “External Device Monitoring” (EDM) and “Start Release” as well as “Stop delay” can be configured (3, [Figure 25](#)):

Chapter	Function	Page
5.4.11	“EDM” + “Start release”	44
5.4.12	“Stop delay”	45

<div style="background-color: black; color: white; padding: 2px; font-weight: bold; font-size: 0.8em;">ATTENTION</div> 	<p>When configuring the start mode and/or using the “Safety override switch,” the general safety notices found in the MSR42 user manual must be followed!</p>
--	---

5.4.5. Micro 400 Light Curtain

In order to configure a Micro 400 light curtain, the input specification window “Micro 400 Light Curtain” must be selected (1 and 4 [Figure 25](#)).

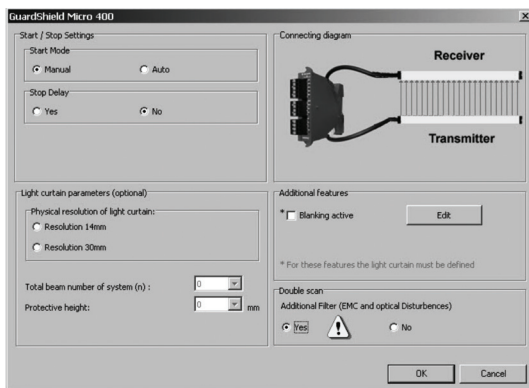

Figure 33: Specification window “Micro 400 Light Curtain”

The corresponding start mode and if required the stop delay function must be selected. The stop delay time itself is defined in the “Safety Output OSSD” window ([See chapter 5.4.12 on page 31](#))

In the Micro 400 specification window it is also possible to specify the resolution and protective height of the Micro 400 light curtain attached to the MSR42 safety controller. When specified, the Micro 400 reaction time $t(LC)$ will be calculated for this exact type of light curtain. This time is only valid if exactly this type of Micro 400 safety light curtain is connected to this MSR42 safety controller. The values: number of beams and reaction time $t(LC)$ will all be printed on the corresponding configuration control document (*Figure 51*).

The safety function of the Micro 400 safety light curtain may be overridden for a period of time through use of the “Safety override” function (*See chapter 5.4.8 on page 28*) or the muting function (*See chapter 5.6 on page 37*). The override function as well as the muting function, is only allowed after a thorough safety analysis according to EN 13849-1 and ISO EN 12100 is completed.

5.4.5.1. Blanking

Certain applications in practice require that only part of the Micro 400 protective field needs to be interrupted without the safety outputs activating. Blanking is activated by selecting the “Blanking active” box in the specification window.

The MSR42 controller offers the following blanking modes. Blanking can be activated either with the Teach-In function (see MSR42 User Manual) or by downloading a configuration file. The differences between these blanking modes are in detail explained in *chapter 5.7 on page 50*.

Blanking Mode	Basic (default) config.	Download of a config. file
• Teach-In Blanking	X (fixed)	X
• Fixed Blanking	-	X
• Floating Blanking	-	X

5.4.5.2. Interrupt Ignore Time

For a limited time a light curtain interruption can be ignored. This may be used when parts are moving at a fast speed through the light curtain and need to be ignored (i.e. will not cause the OSSD outputs to switch) but a person interrupting the light curtain for a time longer than the resulting configured time, that person will be detected (i.e. will cause the OSSD outputs to switch) and cause the output to switch off.

The interrupt ignore time is only available in the “Support mode”.

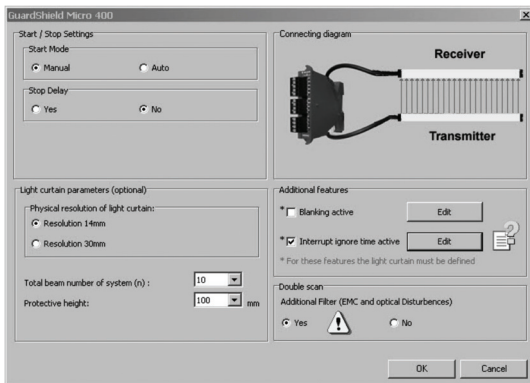

Figure 34: "Interrupt Ignore time" (Support Mode only)

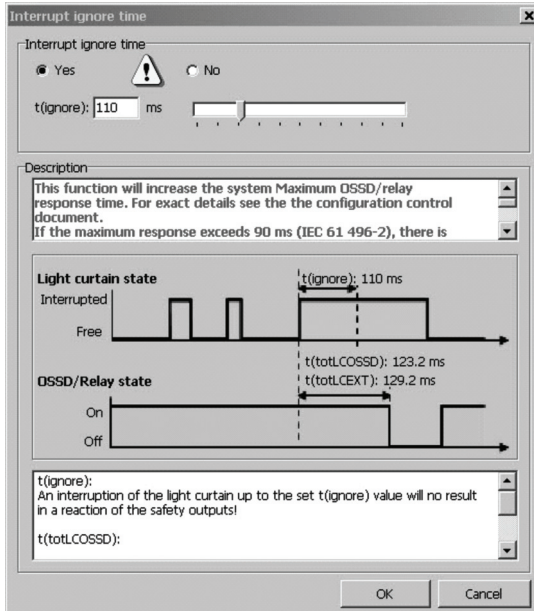

Figure 35: window "Interrupt Ignore time"

Hint:

The light curtain parameters: resolution and protective height must be defined before the interrupt ignore time function can be activated (support mode only)

Important safety advice:

- Interrupt Ignore Time will increase the response time. Recalculate the safety distance.

5.4.5.3. Double Scan Filter

The MSR42 controller scans all light curtain optical elements two times to evaluate the state of the light curtain. This function is very robust against electrical or optical disturbances. Deactivating this filter results in a faster response time.

Warning: Important safety advice

An active double scan filter results in a longer response time. Consider the exact response time when evaluating the safety distance. The configuration control document (*Figure 51*) shows the configured response time, by default with double scan filter active.

Hint: Fast response time

While the connected Micro 400 light curtain is undefined by default, the response time printed on the Micro 400 label is valid. However, the real response time may be faster. Entering the Micro 400 resolution and protective height or the total number of beams (See *Figure 33* Section 'Light curtain parameters') the real response time for this specified Micro 400 and this respective configuration will be shown on the control configuration document.

Warning: Important safety advice, Response time of cascaded Micro 400 light curtains

When connecting multiple Micro 400 safety light curtain systems into one cascaded system (see also Micro400 user manual), the total length of the protective field (respectively the sum of all light curtain beams) have to be considered for response time calculations!

5.4.6. One Device (2 NC)

In the specification window "1 Device (2 NC)" (*Figure 36*), the corresponding start mode, and if required the stop delay function may be configured. The stop delay time itself is defined in the "Safety Output OSSD" window (*See chapter 5.4.12 on page 31*).



Figure 36: Specification window “One Device (2 N.C.)”

5.4.7. One or Two Device (OSSDs)

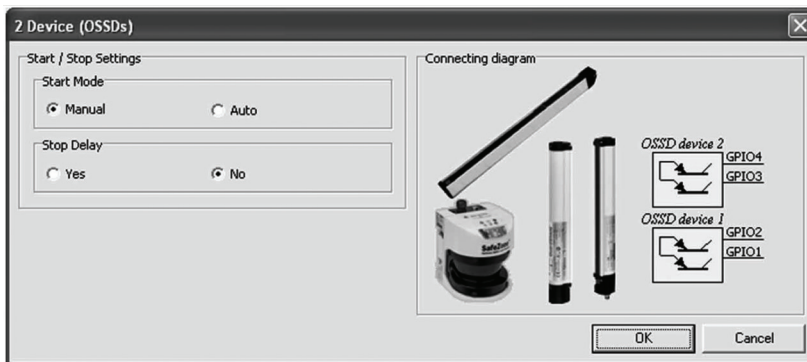

Figure 37: Specification window “One or Two Devices (OSSDs)”

In order to configure an OSSD input device the specification window: “One/Two Device (OSSDs),” must be selected.

Two OSSD input devices can be monitored at the same time: the OSSD outputs of one device at the terminals “GPIO1” and “GPIO2”; the OSSD outputs of a second device at the terminals “GPIO3” and “GPIO4” (Figure 38).

The corresponding start mode and if required the stop delay function may be configured. Both devices will have the same start mode and stop delay function. The stop delay time itself is defined in the “Safety Output OSSD” window (See chapter 5.4.12 on page 31)

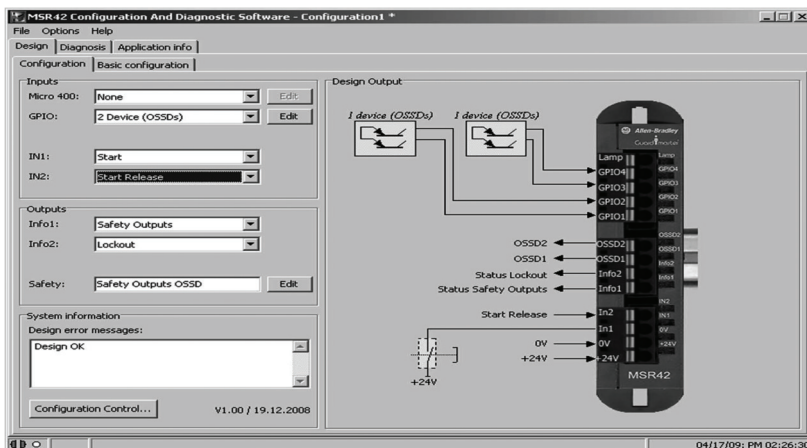

Figure 38: Two OSSD input devices with manual start example

5.4.8. Safety override

Certain applications in practice require that the safety light curtain protective field needs to be overridden “manually” without the MSR42 safety contacts opening. A typical example of such an application is during the installation or service of a machine. It should be possible to run the machine even if the protective field is interrupted.

If the risk analysis of the application shows that it is necessary to monitor the function of the override lamp during such a safety override condition, this feature may be configured (*Figure 39*).

Indication of Override

If Override is configured then a lamp must clearly indicate this to the operator. The MSR42 control module monitors the connection of the lamp. If this lamp is defective or not connected, the MSR42 controller will immediately cancel the override function (i.e. return to the safe mode).

However, according to the risk analysis of the application, the monitoring of the indication lamp may be deactivated (*Figure 39*). The lamp will still be activated if override is selected, but it is no longer monitored.

Important safety notice:

The Override lamp must be mounted near the protective field, clearly visible to the operator.

5.4.8.1. Override Micro 400 Safety light curtain

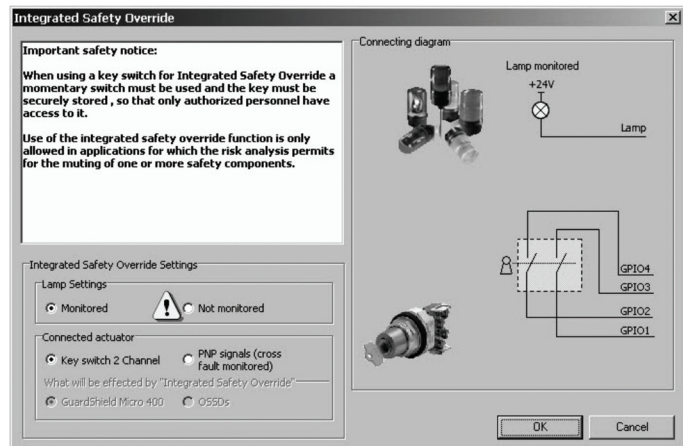

Figure 39: Specification window “Safety override”

Two methods can be selected to override a Micro 400 light curtain:

1. Key Switch 2 Channel (A maintenance key or service enable switch is typically used to initiate a “Safety Override” mode.)
2. PNP signals (cross fault monitored) (For special applications it is also possible that the two safety override switch signals are replaced by two safety signals (e.g. a safety PLC gives a maintenance signal that the machine should run at a lower speed for service purposes). In such an application a key switch must still be placed in series with the two safety signals. Only when the key switch is activated and the safety signals are “high”, will the safety override function be active.)

<p>WARNING</p>	<p>For PNP signals: It must be made sure that a short circuit of one of these safety signals to ground, to +24V DC or between each other must be detected by the external safety controller and once detected this external safety controller has to immediately stop the dangerous machine movement.</p>
<p>WARNING</p>	<p>When the safety prevention switch contacts are closed and the MSR42 control unit is powered up, the safety override function will be immediately active.</p>

The opening of only one contact will lead to a stop of the override function within the reaction time of the MSR42 control unit. The override function can only be re-activated after both contacts (or signals) have been opened (or deactivated) at the same time.

5.4.8.2. Override One Device (OSSD)

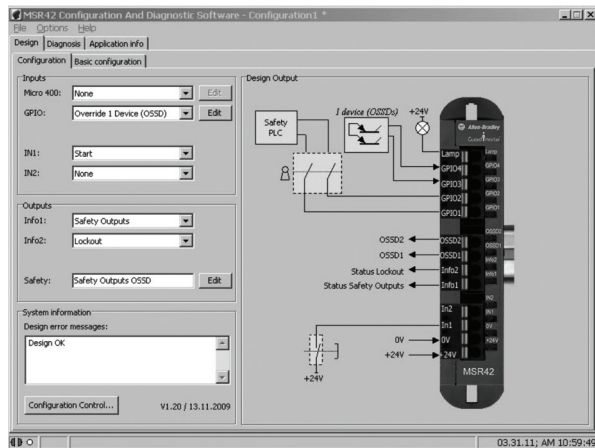



Figure 40: Specification window "Safety override"

This function shows how to override a safety device with OSSD outputs (e.g GuardShield Safe 4). The MSR42 safety controller will be configured with Manual Start (Reset). Therefore for In1 or In2 the option 'Start' must be selected.

One method can be selected to override an OSSD device:

1. PNP signals (cross fault monitored) (For special applications it is also possible that the two safety override switch signals are replaced by two safety signals (e.g. a safety PLC gives a maintenance signal that the machine should run at a lower speed for service purposes). In such an application a key switch must still be placed in series with the two safety signals. Only when the key switch is activated and the safety signals are "high," will the safety override function be active.)

	<p>WARNING</p> <p>It must be made sure that a short circuit of one of these safety signals to ground, to +24V DC or between each other must be detected by the external safety controller and once detected this external safety controller has to immediately stop the dangerous machine movement.</p>
	<p>WARNING</p> <p>When the safety prevention switch contacts are closed and the MSR42 control unit is powered up, the safety override function will be immediately active.</p>

The opening of only one contact will lead to a stop of the override function within the reaction time of the control unit. The override function can only be re-activated after both contacts (or signals) have been opened (or deactivated) at the same time.

5.4.9. Muting Micro 400

Certain applications in practice require that the protective field of the Micro 400 light curtains need to be muted "automatically" without the safety contacts opening. A typical example of such an application is a conveyor belt. It should be possible to transport the goods on a pallet through the protective field without stopping the pallet movement.

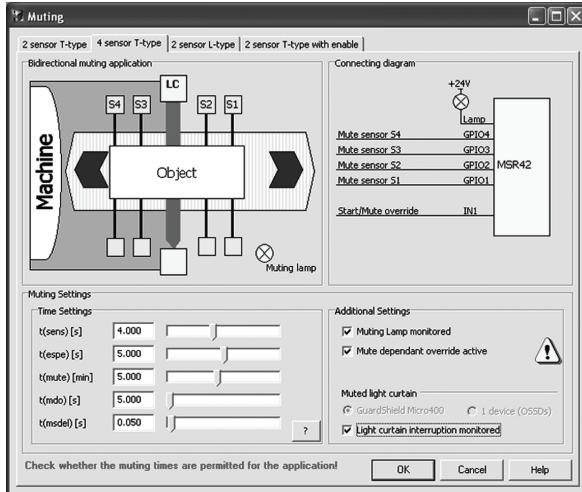

Figure 41: Specification window “Muting Micro 400”

A detailed description of “Muting” is given in [chapter 5.6 on page 37](#).

5.4.10. Muting other device (OSSDs)

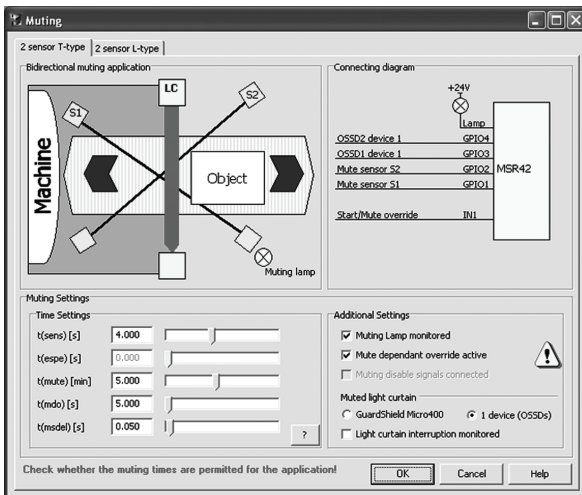

Figure 42: Specification window “Muting other device (OSSDs)”

The MSR42 controller also offers the possibility of connecting one GuardShield safety light curtain or one laser scanner for muting applications. Due to the limited number of GPIO's, only two sensor T-type, and two sensor L-type muting is possible with this configuration type. The time sequences which can be adjusted are equal to those for the muting of a Micro 400 system and are described in [chapter 5.6 on page 37](#). The only difference is that instead of the Micro 400 safety light curtain now the non-Micro 400 safety light curtain is muted.

5.4.11. Function “EDM” + “Start Release”

High energy applications with very high power ratings require switching circuits with corresponding switching capacities. If the switching capacity of the integrated OSSD outputs and/or extension relay module are insufficient, then external force guided, power contactors must be used, whose function is monitored using contact feedback. This function is called EDM (= External Device Monitoring) and is found by clicking on the “Safety Outputs OSSD” Edit button (3, [Figure 25](#)).

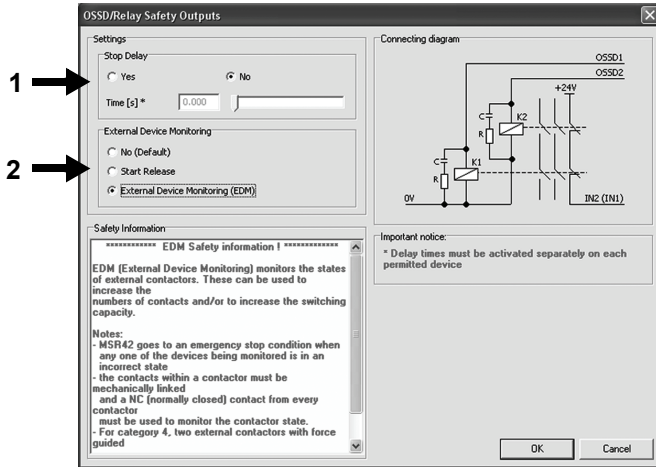

Figure 43: Stop delay setting and activating the function EDM or start release

If the External Device Monitoring (EDM) field is chosen for external contactor monitoring (#2 in Figure 43), this function is active for both the safety outputs OSSD and extension relay module. The EDM function forces the safety outputs of the MSR42 control unit to open immediately if the monitored external N.C. circuit is not opened within 300 ms. The start release function only allows a start if the N.C. contact of the external contactor is closed.

With EDM configured, a successful start is only allowed if the monitored signal is initially “high,” as well as this signal going to “low” within 300 ms of the MSR42 start. For start release only the status at the beginning is relevant. The monitored signal must be “high” before a start is allowed.

IMPORTANT	For the configuration of the EDM function, it is also important to follow the safety notes for connections (see Installation Instruction MSR42).
------------------	--

5.4.12. Function “Stop delay”

This function is found by clicking on the “Safety Output OSSD” Edit button (3, Figure 23). This function is activated by simply clicking on the “Yes” box (#1 in Figure 43). Thereafter a stop delay time may now be defined for the safety outputs.

IMPORTANT	This “Stop delay” function must be activated for the corresponding safety component, in the respective specification window (see chapter 5.4.5, 5.4.6, and 5.4.7). The advantage of this is that one safety component may switch the safety output with no time delay, and a second component will switch the safety output with a time delay. The total reaction time is calculated out of the sum of the delay time [t(delay)], the reaction time of the MSR42 control unit [t(mmLC)], the reaction time of the connected safety component, the reaction time of the external contactor, and the machine stop time.
------------------	---

ATTENTION 	When configuring a stop delay for a safety light curtain, this time (delay) must be fully considered in the minimum safety distance calculation.
---	--

5.5. Download, Verify & Upload

5.5.1. PC ⇌ MSR42 (Download)

When a configuration is created which meets the requirements of the relevant application, it now needs to be downloaded into the MSR42 control module.

The following steps must be carried out for a successful download:

1. Attach the Optical Interface to the MSR42 control module.
 2. Disconnect the power supply to the MSR42 module.
 3. Connect the Optical Interface to your PC.
 4. Select menu item “File” – “PC -> MSR42 (Download).”
 5. Enter the password and press “OK”-button (*Figure 44*).
- (to change the password see *chapter 5.3.2.2 on page 16*)



Figure 44: Enter user password

Using the unit protection key, see *chapter 5.5.3 on page 35*.

7. The “Controller Description” window opens (*Figure 45*) and requests the MSR42 device no. and a “designation.” The device no. can be found on the label of the control unit (*Figure 46*). Enter this information and press “OK” button.

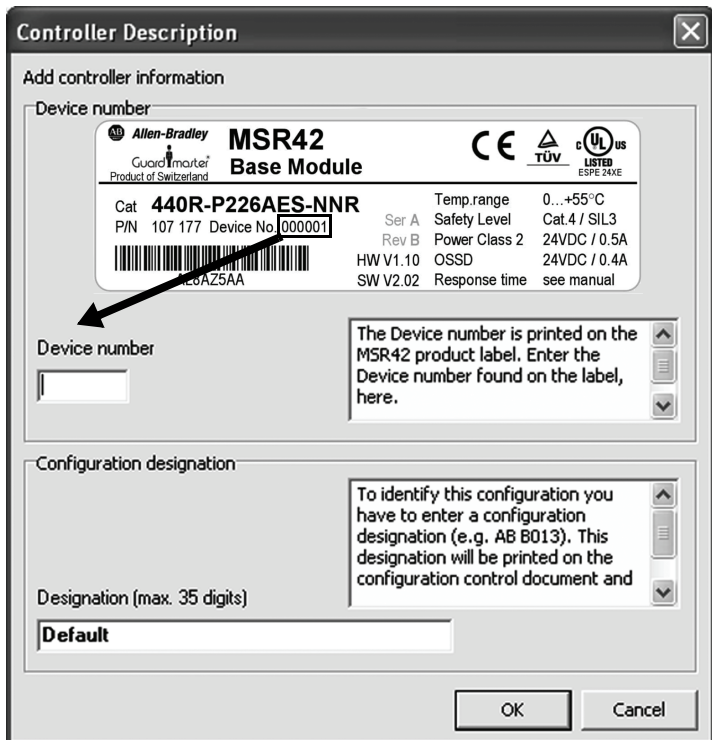

Figure 45: Input of device no. and designation

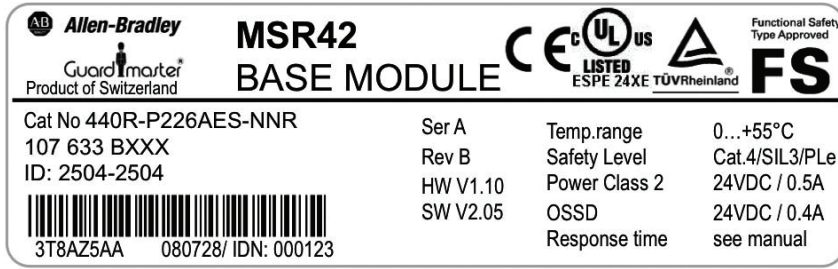

Figure 46: Device no. printed on label

IMPORTANT

The device number and designation must be entered. These inputs are later shown on the configuration control document and guarantees the product identification.

8. A window will appear, which shows the process of the communication from the PC to the MSR42 control module (Figure 47).
9. Now reconnect the +24V DC power supply to the MSR42 control module, and the data transmission will begin.

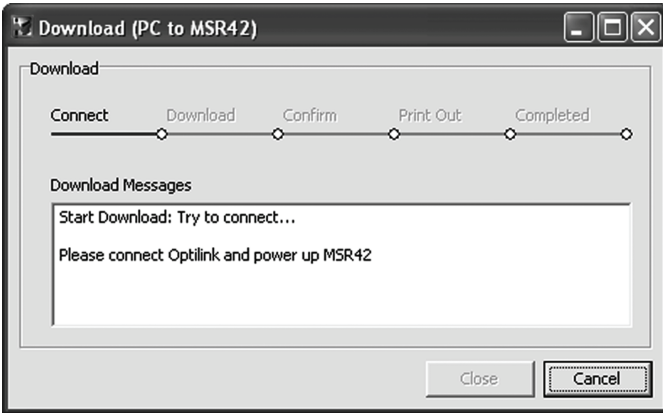

Figure 47: Communication PC to MSR42

10. After the download has started, the window “Configuration control document” window will appear on your monitor (Figure 48).

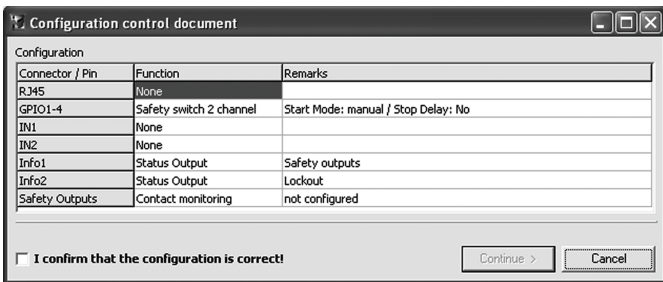

Figure 48: Control document

11. Review the configuration data in this window!
12. Check the control box to confirm the configuration is correct. After this confirmation the “Continue” Button will be enabled

IMPORTANT	<p>In case a MSR42 control unit is configured with a new configuration by an authorized person, the reaction times of the control unit may have changed. Therefore it is very important that after each configuration procedure:</p> <ol style="list-style-type: none"> a. The new, valid configuration control document is printed-out (step 14) and put with the corresponding controller so that it is always present for maintenance and service purposes and b. The new reaction times are controlled and verified that they adhere to the limits of the risk analysis for the corresponding application.
------------------	--

13. This new configuration will become active, only after the “Continue” button within the “Configuration control document” is selected. If the “Cancel” button is selected, the original (old) MSR42 configuration will remain active.

14. Print “Configuration control document” (*Figure 49*).

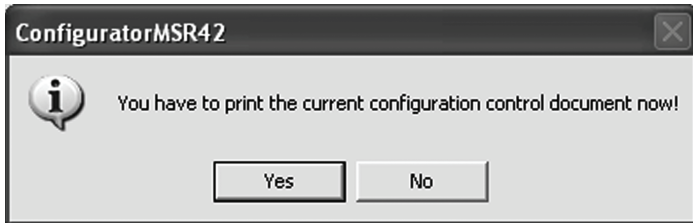

Figure 49: Print Configuration Control Document

15. Sign the Configuration Control Document (*Figure 51*) and the “Configuration Changed” label. Attach this label to the newly configured MSR42 control unit (*Figure 50*) and confirm with “OK.”

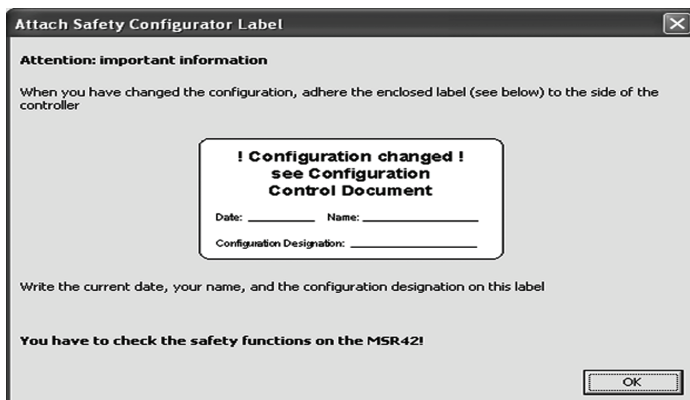

Figure 50: Confirm and put the configuration changed label on the MSR42

16. Now the configuration procedure is finished and the new configuration will be active.

17. Verify download according *chapter 5.5.2 on page 34*.

5.5.2. Verify download

1. Check resolution of MSR42 protective field with a test rod according the GuardShield Micro 400 user manual
2. Verify the Micro 400 safety distance according current response time given in the configuration control document and resolution.
3. Check the correct function of all configured safety components.
4. Check configured delay time.
5. Verify “Safety Override” or “Muting” function.
6. Sign printed label and configuration control document.
7. Store the configuration control document together with the MSR42 user manual (depending on configuration also together with the technical description of light curtain user manuals) close to the application (e.g. machine control cabinet).

CEDES Safety & Automation AG Configuration control document
 A Rockwell Automation Company Configuration designation Default (Configuration1)

The MSR42 safety control units may only be configured by authorized people. This sheet shows the actual system parameters of the configurator and has to be stored together with the manual. The device number has to correspond to the number on the control document. Old control documents have to be exchanged! To receive more information see manual or contact your local ROCKWELL AUTOMATION Partner.

User registration:

Company:	City:
First Name:	Country:
Name:	Phone:
Address:	Fax:
Zip code:	Email:

Current set up

Installed hardware:	MSR42
Attached GuardShield Micro 400	Not connected
GuardShield Micro 400: Number of beams:	not specified
GuardShield Micro 400: Response time t(LC):	0.00 ms
Controller response time t(C):	8.40 ms
Stop delay time t(delay):	0.00 ms
Interrupt ignore time t(ignore):	0.00 ms
Response time for safety component on GPIO t(GPIO):	0.00 ms
Response time for extension modul t(em):	6.00 ms

Configuration

Filename (Configuration file):	Configuration1
Configuration designation	Default
Device No.	000000

Connector / Pin	Function	Remarks
RJ45	None	
GPIO1/2	None	
GPIO3/4	None	
IN1	None	
IN2	None	
Info1	Status Output	Safety outputs
Info2	Status Output	Lockout
Safety Outputs	Contact monitoring	not configured

(ChA: OSSD outputs, ChB: Relay outputs)

Additional safety information

Safety category (EN ISO 13849):	PLe, Cat. 4
SIL level (EN/IEC 61508):	3
Minimal off time:	82 ms

11/3/2009 / Signature: _____

Figure 51: Configuration control document for MSR42

5.5.3. Configuration Protection

The Unit Protection Key can be set to protect your MSR42 controller against unauthorized configuration changes. If set the configuration of the MSR42 can only be changed if the correct Unit Protection Key is entered.

The key is set, if selected, while downloading the configuration into the MSR42 controller. The MSR42 controller checks if this key is enabled after the MSR42 controller is powered up ([chapter 5.5.1 on page 31](#) step 7).

IMPORTANT

Store your Unit Protection Key safely and assure that only authorized personal have access to it. Without the Unit Protection Key, a protected MSR42 controller may not be reconfigured. It has to be replaced with a new control unit!

Following the download procedure according *chapter 5.5.1 on page 31* selecting the flag “Use Unit protection key” (*Figure 44*) the “Password dialog” window is expanded (*Figure 52*) and offers the following options:

- Set new unit protecting key
Set a key for an unprotected controller.
Enter the user download password, the protection key and confirm the key according the dialog window.
- Download with existing unit protection key
Download a configuration to a protected MSR42 controller.
Enter the user download password and the existing protection key.
- Change existing unit protection key
Download a configuration to a protected MSR42 controller and change the key.
Enter the user download password, the existing protection key, the new key and confirm the new key.
- Clear existing unit protection key
Download a configuration to a protected MSR42 controller and clear the key.
Enter the user download password and the existing protection key.

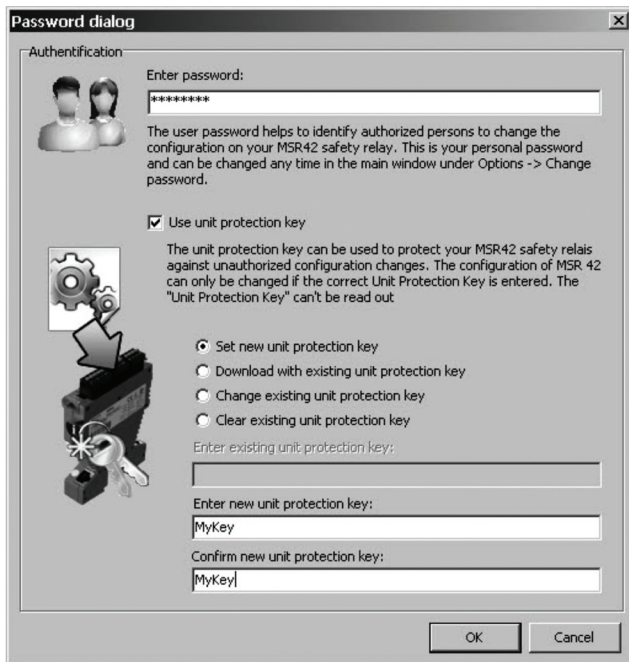

Figure 52: Password dialog for downloading and protecting a configuration

The download procedure continues according 5.5.1 step 7.

In case an invalid user password is used, the following message appears:



Figure 53: Wrong password message

5.5.4. MSR42 ⇄ PC (Upload)

To review the configuration in a MSR42 control unit, the configuration data may be read out as follows:

1. Attach the Optical Interface to the controller
2. Disconnect the power supply to the MSR42 controller.
3. Connect the Optical Interface to the PC USB interface.
4. Select Menu item "MSR42 -> PC (Upload)" (#1 in [Figure 21](#)).
5. A window will appear which shows the communication from the PC to the MSR42 control unit.
6. Now connect the +24V DC power supply to the MSR42 control unit, and the data transmission will start
7. After completion of the data transmission, a window will appear to confirm if the communication was successful.
8. In the "Design" tab, all of the configuration data is now available and can be verified. Check also the "Configuration Control ..." button for an overview of the configuration

5.6. Muting

5.6.1. General

A light curtain may be "automatically" overridden safely as a temporary measure in muting applications (e.g. a defined object on a conveyor should be able to pass through a safety light curtain without triggering an emergency stop).

With the help of MSR42 Safety Configuration Tool four Muting modes can be configured for the Micro 400 safety light curtain.

- Two sensor, T-type muting (bidirectional operation)
- Four sensor, T-type muting (bidirectional operation)
- Two sensor, L-type muting (unidirectional operation)
- Two sensor T-type with muting enable signal (bidirectional operation)

IMPORTANT

A detailed description about muting, muting restrictions as well as hints for the installation are given in the standard IEC 62046. Additional hints are mentioned in the attachment A7 of IEC 61496-1.

Each of these functions can be configured

- with manual or automatic reset
- with or without muting lamp monitoring
- with or without monitoring of light curtain interruption
- various timing sequences and various maximum muting times
- with or without mute dependant override
- with or without muting sensor output delay

5.6.2. Muting lamp

A muting lamp should be connected to warn an operator in the event that the light curtain is muted (see details in IEC 62046).

The MSR42 may be configured to monitor a muting lamp. If it is configured with monitoring and the lamp is defective or not connected, the MSR will not initiate a muting condition, or will discontinue an existing muting condition.

If an error in the muting sequence has occurred, the muting lamp will blink (at 1 Hz), indicating that the muting condition will not be initiated, or has been discontinued.

If the controller is configured to not monitor the muting lamp, a connected lamp will still work but it will not be monitored. Not monitored means that if the lamp is defective or not connected the light curtain will still be muted according the muting sequence.

5.6.3. Muting sensors

IMPORTANT	Detailed information about muting sensors (e.g. positioning) is given in the standard IEC 62046.
------------------	--

Mechanical muting sensors must have an opening contact (i.e. N.C.; sensor not activated = contact closed = signal high).

Photoelectric muting sensors do not have to be certified according to safety type 2 or 4 of IEC 61496-1/-2. The detection zone of the muting sensors must be within 30° of the horizontal and are mounted at a height suitable to detect a person's leg (see IEC 62046).

IMPORTANT	The muting sensors should detect the material on a pallet and not the pallet itself.
------------------	--

When the material on the pallet has small openings or gaps which can disturb the muting sequence the output signal of the muting sensor signals can be configured with an output delay time (*See chapter 5.7.5 on page 53*).

5.6.4. Mute dependant override function

Normal activation of the manual start button is only permitted if no muting sensors are activated and the light curtain is not interrupted.

An error in the muting sequence will not allow a muting condition. If the safety light curtain is then interrupted the MSR42's OSSD outputs will switch off. This typically leads to a cessation of movement.

In such a case it may not be easy to move the material out of the protected area. If this situation is anticipated (an error in the muting sequence) the start button may be configured to provide also a mute dependant override function. The MSR42's OSSD outputs may be reactivated temporarily by activating the start button (manual start). The maximum allowable duration $t(mdo)$ for this override function can be configured and depends on risk analysis of the application.

The mute dependant override function is only possible when manual start is configured. Therefore the configuration of a start button is strongly recommended.

The mute dependant override function should be activated by a push button or a spring loaded key switch. The push button / key switch should be mounted at a location from which the dangerous area can be seen.

The mute dependant override function is automatically terminated after the mute dependant override time $t(mdo)$ has elapsed (when configured), or when the safety light curtain is no longer interrupted, whichever occurs first.

5.6.5. Sensor output delay function

Various positions and sizes of loads on the pallet may make it difficult to guarantee an uninterrupted muting signal over the entire passage through the guarded area. For this reason an off-delay time $t(msdel)$ for the muting sensor inputs and the light curtain can be configured. This configuration is only allowed depending on the application and risk analysis.

ATTENTION

It must be confirmed that the configuration of a muting sensor output delay does not have influence on the safety of the application. For example, the position of the muting sensors may have to be considered.

5.6.6. Muting with enable signal

This function is only available for 2 sensor T-type with enable applications. In some applications muting should only be possible at certain times, for example only when a conveyor is running. Likewise when the conveyor stops the muting function should also stop and the light curtain should return to the normal safety mode. In this example the conveyor run signal (S3 in [Figure 54](#)) is also the muting enable signal. Only when this signal is “low” can muting be initiated.

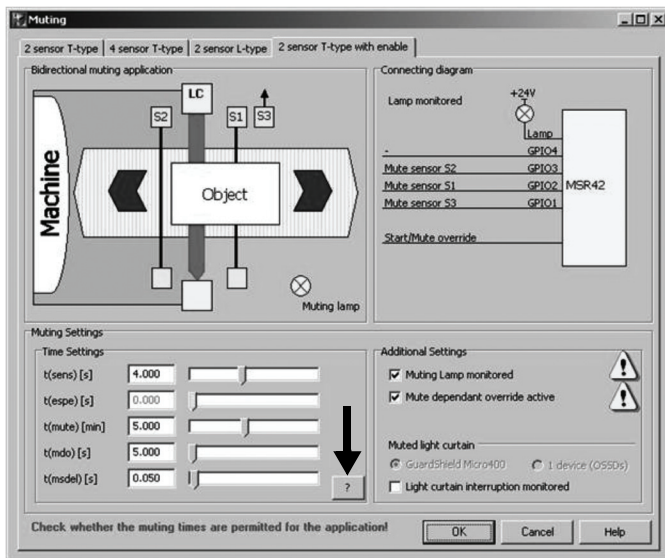

Figure 54: 2 sensor T-type with enable signal (S3). Click on “?” to display timing diagram

5.6.7. Muting disable function

This function is only available for 2 sensor T-type and 2 sensor L-type applications.

If this function is used two additional mute disable signals are required. These signals must be “high” in order for a mute condition to take place. In some applications these signals are provided by sensors placed to detect a person moving into the dangerous area, either to the left or right of the object. If either of these signals is “low” (e.g. a sensor detects a person) a muting condition can not take place, or if already in progress, the muting condition will cease. Muting can be initiated again only after both disable signals have simultaneously gone “low”. ([Figure 59](#) and [Figure 63](#))

IMPORTANT

The mute dependent override function supersedes the muting disable signals.

5.6.8. Safety light curtain interruption monitoring function

Some applications require that the interruption of the safety light curtain be part of the muting signal sequence. When this function is configured the MSR42 will detect an interruption of the safety light curtain and it will also monitor:

- A. The time from when the muting condition has started until the safety light curtain is interrupted.
- B. The time from when the safety light curtain is no longer interrupted until the muting condition has stopped.

This time is referred to as “t(espe)”.

5.6.9. 43B Muting time recorder

The MSR42 offers the ability to configure many different timing sequences. During installation of a complete muting system it is often not clear what configured time values will guarantee trouble free operation. Small variations (e.g. in object size) may lead to unnecessary machine stoppage. To determine the timing of a given installation it is possible to measure the real timing sequence with the MSR42 control unit.

Based on these measurements, optimized timing values can be selected so that the application runs reliably, while fulfilling the safety requirements of the risk analysis.

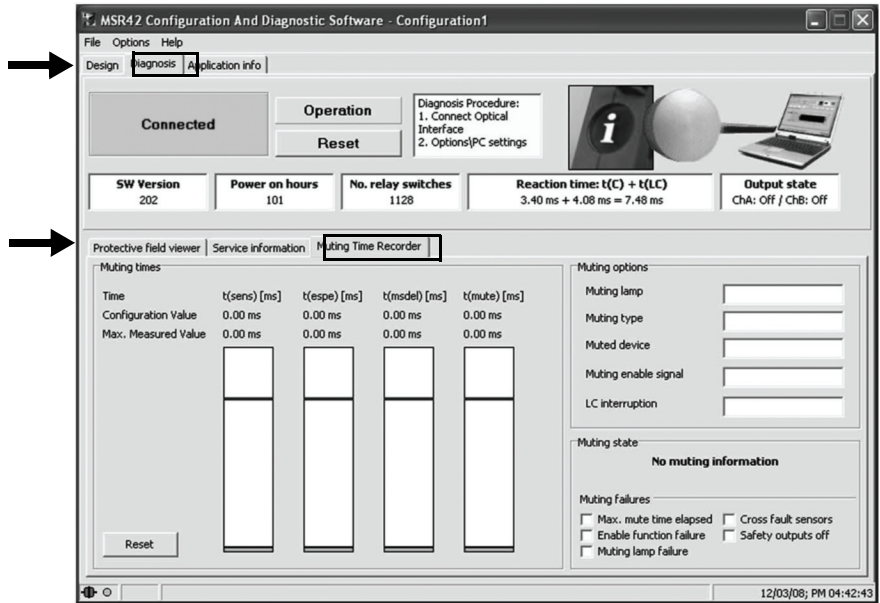

Figure 55: Tab sheet "Muting time recorder"

5.6.10. 44B Setup: 2 sensor T-type

Figure 56 shows a schematic arrangement for a two sensor, crossed beam, bidirectional muting application: "two sensor T-type." For this muting mode either the Micro 400 or the GuardShield safety light curtains may be muted.

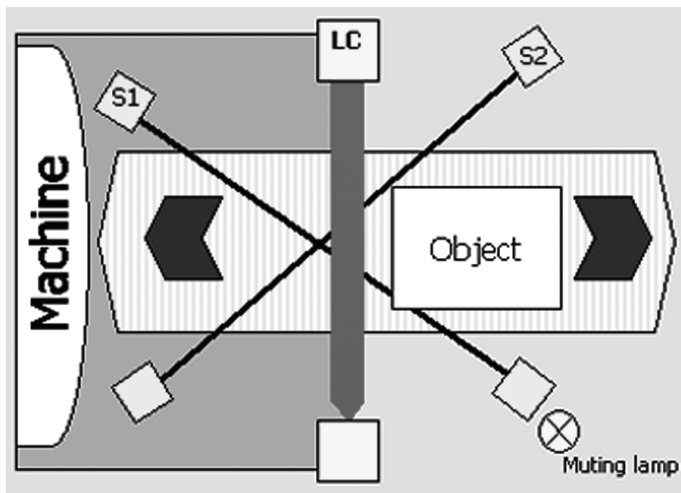

Figure 56: Example, "Two sensor (S1 and S2) T-type" muting

The crossing point of the two light beams should be situated behind the sensing field of the safety light curtain in the direction of the dangerous area.

The height of the crossing point of the two muting sensors should be at the same level as or higher than the lowest beam of the light curtain.

The distance from the crossing point to the protective field of the safety light curtain should be as short as possible.

It should not be possible for a person to enter the dangerous area undetected to the left or right of the object during the muting process.

IMPORTANT

A detailed description about muting, muting restrictions as well as hints for the installation are given in the standard IEC 62046. Additional hints are mentioned in the attachment A7 of IEC 61496-1.

Figure 57 shows the corresponding timing sequence for such an arrangement.

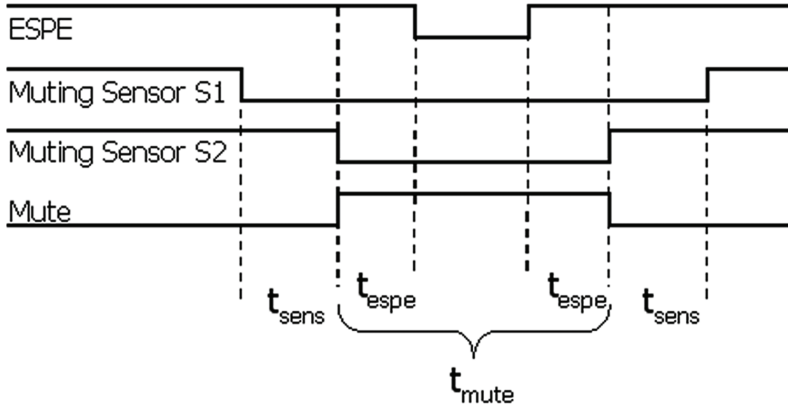

Figure 57: Timing sequence for “Two sensor T-type” muting

Muting of the safety light curtain is achieved only when muting sensor S1 and S2 are activated within the specified time $t(\text{sens})$. Since this muting mode is bidirectional the muting sequence will also function in reverse (i.e. Muting sensor one before muting sensor two, or two before one are both allowed). Both signals however may not arrive at the same time ($t(\text{sens})$ min.). The muting condition will stop if one of the muting sensors is not activated or if the configured maximum muting time $t(\text{mute})$ is exceeded (muting time out).

The following parameters can be configured in the configuration window (Figure 58) for “Two sensor T-type” muting.

Parameter	Default Value	Max./Min. Values	Possible Settings
T(sense) [Figure 57]	4 s	Min.: 50 ms Max.: 10 s	Min.: N x 0.05 s
T(mute) [Figure 57]	5 min	Min.: 0 s Max.: 10 days	(*)
T(msdel) [5.6.5]	50 ms	Min.: 0 ms Max.: 2.55 s	N x 0.01 s
Muting lamp monitoring [5.6.2]	yes		yes/no
Mute dependant override [5.6.4]	yes		yes / no
T(mdo) [5.6.4]	5 s	Min.: 0 ms Max.: 20 min	N x 5 s
Mute disable signal [5.6.7]	no		yes / no
Micro 400 interruption monitoring [5.6.8]	no		yes / no
T(espe) [5.6.8]	5 s	Min.: 0 ms Max.: 10 s	N x 0.05 s (*)

Table 1 (* = a setting smaller or close to the total response time may influence the stability of the muting system)

A time $t(\text{sense})$ of 4 s is recommended in IEC 62046.

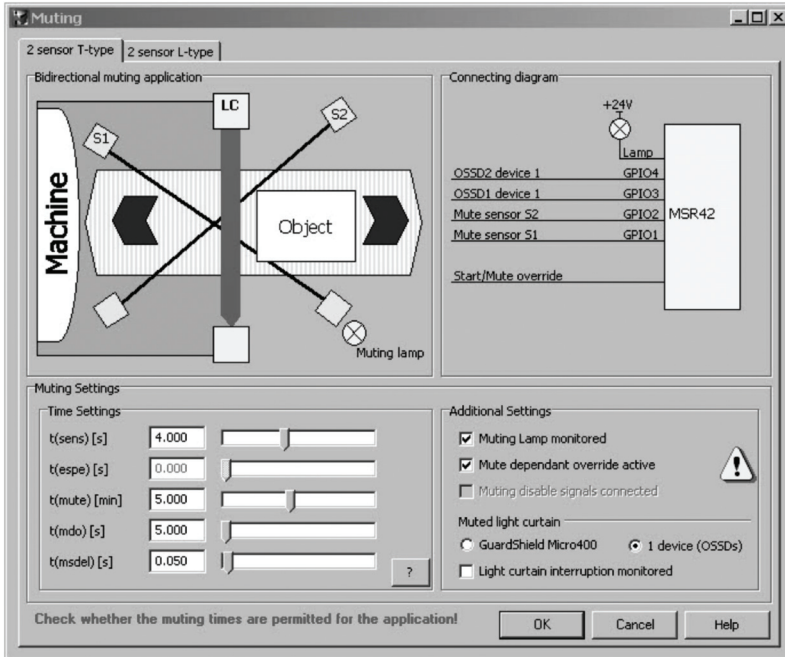

Figure 58: Configuration window for “Two sensor T-type” muting with 1 device (OSSD’s) safety device

Figure 59 shows the wiring diagram for an example of a MSR42 control unit configured with the “two sensor, T-type” muting mode.

For this muting mode two mute disable inputs may be configured. If selected, these signals must be “high” in order for a mute condition to take place (See chapter 5.6.7 on page 39).

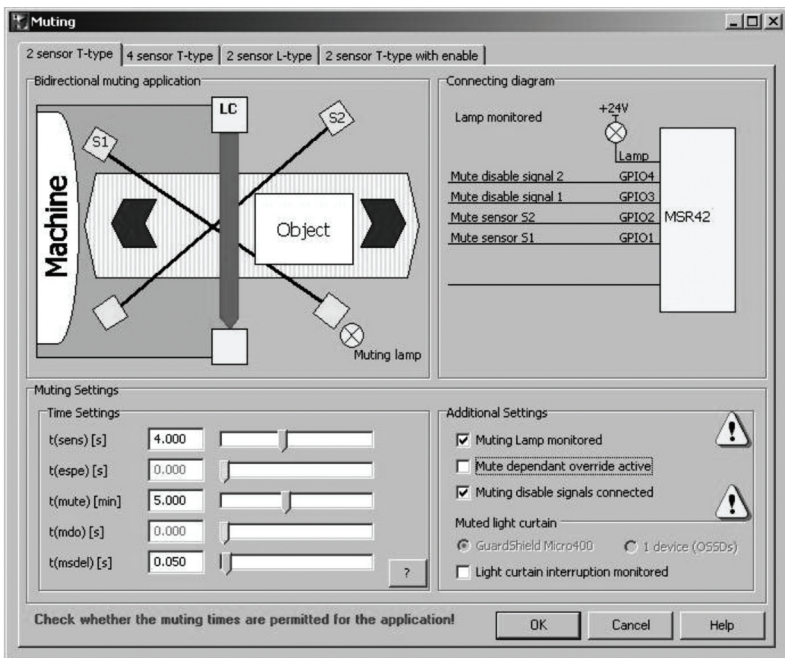

Figure 59: Wiring diagram for “two sensor T-type” muting with Micro 400 and disabling signals

5.6.11. Setup: four sensor T-type

Figure 60 shows a schematic arrangement for a four sensor, parallel beam, bidirectional muting application: “four sensor T-type.” Only the Micro 400 may be used in this mode.

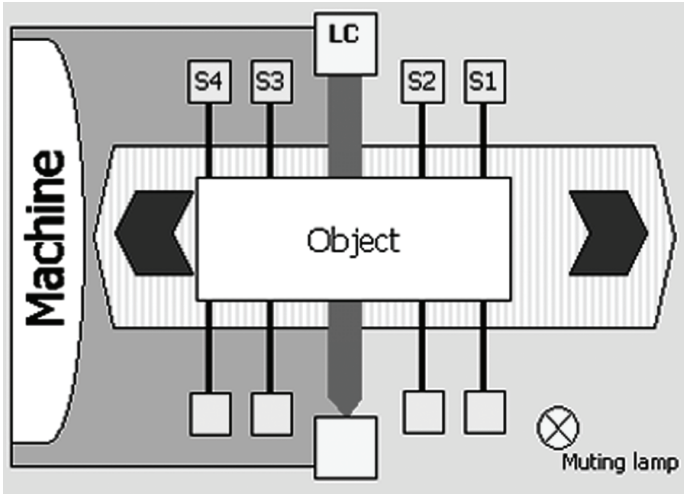

Figure 60: Example, “four sensor (S1 - S4), T-type” muting

This muting mode is similar to the “two sensor, T-type w/enable signal” muting (See chapter 5.6.6 on page 39), and should also be considered when the size and position of the pallet load is irregular, or the size of the pallet is much smaller than the width of the conveyor. Due to the two sensor input from either side of the light curtain, however an external enable signal (e.g. conveyor run signal) is not necessary. This mode may require more space than the “two sensor T-type w/enable signal” muting mode.

Sensors two and three (closest to the light curtain) should be mounted within 200 mm of the light curtain so that it is difficult for a person to enter the dangerous zone undetected by preceding or following a load system into the dangerous zone.

The distance between any two muting sensors must be greater than 250 mm so that they cannot be activated simultaneously by a person’s leg.

The distance between sensor S1 and S4 shall be such that a cylindrical object with a diameter of 500 mm with its axis parallel to the protective field cannot activate the muting function when moved in any point of the gate at any speed up to 1.6 m/s.

The muting sensors S1 – S4 should detect the objects on pallets and not the pallet itself. When this is impractical additional measures may be necessary to prevent people from entering the zone by sitting on the pallet.

It should not be possible for a person to pass undetected to the left or right of the object during the muting process.

IMPORTANT

A detailed description about muting, muting restrictions as well as hints for the installation are given in the standard IEC 62046. Additional hints are mentioned in the attachment A7 of IEC 61496-1.

Figure 61 shows the corresponding timing sequence for such an arrangement.

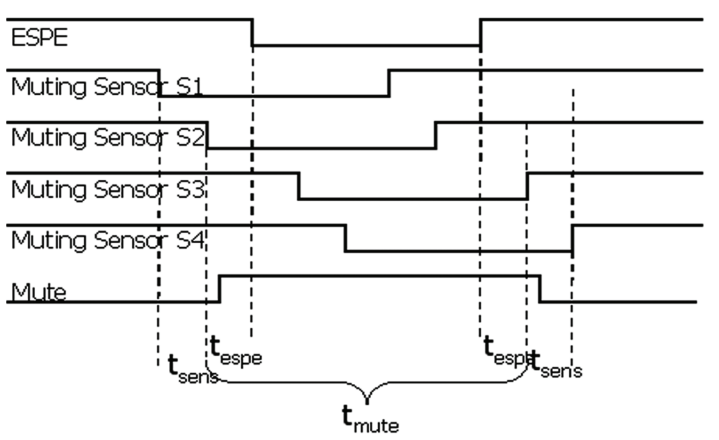

Figure 61: Timing sequence for “four sensor, T-type” muting

Muting of the Micro 400 light curtain is achieved only when muting sensor S1 and S2 are activated within the specified time $t(sens)$. For a successful muting sequence all four sensors must be simultaneously activated for a certain time period. The muting condition will stop when either sensor S3 or S4 is deactivated, or the maximal muting time $t(mute)$ is exceeded (muting time out). Since this muting mode is bidirectional, the muting sensor sequence will also function in reverse (i.e. $S4 \Rightarrow S1$).

The following parameters can be configured in the configuration window (*Figure 62*) for “four sensor T-type” muting.

Parameter	Standard Value	Max./Min. Values	Possible Settings
T(sense) [Figure 57]	4 s	Min.: 50 ms Max.: 10 s	Min.: $N \times 0.05$ s
T(mute) [Figure 57]	5 min	Min.: 0 s Max.: 10 days	(*)
T(msdel) [5.6.5]	50 ms	Min.: 0 ms Max.: 2.55 s	$N \times 0.01$ s
Muting lamp monitoring [5.6.2]	yes		yes/no
Mute dependant override [5.6.4]	yes		yes / no
T(mdo) [5.6.4]	5 s	Min.: 0 ms Max.: 20 min	$N \times 5$ s
Mute disable signal [5.6.7]	no		yes / no
Micro 400 interruption monitoring [5.6.8]	no		yes / no
T(espe) [5.6.8]	5 s	Min.: 0 s Max.: 10 s	$N \times 0.05$ s (*)

Table 2 (* = a setting smaller or close to the total response time may influence the stability of the muting system)

A time $t(sense)$ of 4 s is recommended in IEC 62046

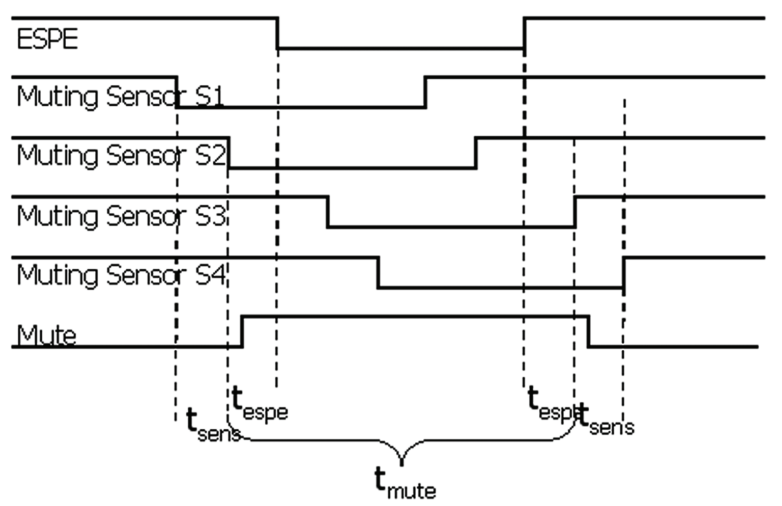

Figure 62: Configuration window for “four sensor T-type” muting

Figure 62 also shows the corresponding wiring diagram of the MSR42 control unit configured with the “4 sensor T-type” muting mode.

5.6.12. Setup: two sensor L-type

Figure 63 shows a schematic arrangement for a two sensor, parallel beam, unidirectional muting application: “two sensor L-type.” Either the Micro 400 or a GuardShield safety light curtain may be muted in this manner.

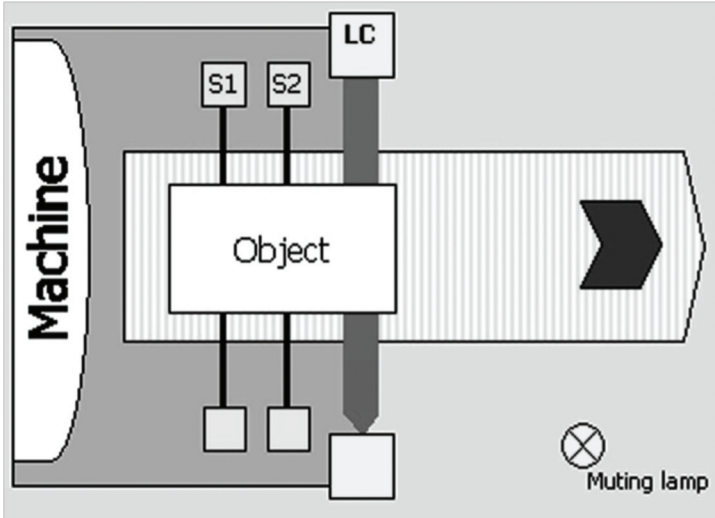

Figure 63: Example, “two sensor (S1 and S2) L-type” muting

This muting mode is used to allow a load to exit a dangerous area while helping prevent access from outside the dangerous area. The object coming from the dangerous area interrupts the two muting sensors initiating the muting of the safety light curtain. As the object continues to move through the protective field muting remains active until the light curtain is no longer interrupted.

According to IEC 62046:

Muting of the safety light curtain is initiated only after muting sensor S1 and S2 are activated within the specified time $t(sens)$. The muting condition will stop after $t(espe)$ is exceeded, the light curtain is no longer interrupted or the maximum muting time $t(mute)$ is exceeded (muting time out), which ever occurs first.

Figure 64 shows the corresponding timing sequence

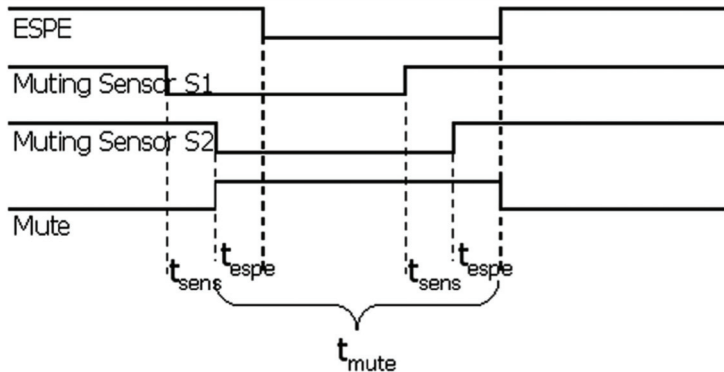

Figure 64: Timing sequence for “two sensors L-type” muting

It should not be possible for a person to pass undetected to the left or right of the object during the muting process.

IMPORTANT	A detailed description about muting, muting restrictions as well as hints for the installation are given in the standard IEC 62046. Additional hints are mentioned in the attachment A7 of IEC 61496-1.
------------------	---

The following parameters can be configured in the configuration window (Figure 65) for “two sensor L-type” muting.

Parameter	Default Value	Max./Min. Values	Possible Settings
T(sens) [Figure 64]	2 s	Min.: 50 ms Max.: 10 s	Min.: N x 0.05 s
T(mute) [Figure 64]	5 min	Min.: 0 ms Max.: 10 days	(*)
T(msdel) [5.6.5]	50 ms	Min.: 0 ms Max.: 2.55 s	N x 0.01 s
Muting lamp monitoring [5.6.2]	yes		yes/no
Mute dependant override [5.6.4]	yes		yes / no
T(mdo) [5.6.4]	5 s	Min.: 0 ms Max.: 20 min	N x 5 s
Mute disable signal [5.6.7]	no		yes / no
Micro 400 interruption monitoring [5.6.8]	yes		yes
T(espe) [5.6.8]	2 s	Min.: 0 s Max.: 10 s	N x 0.05 s (*)

Table 3 (* = a setting smaller or close to the total response time may influence the stability of the muting system)

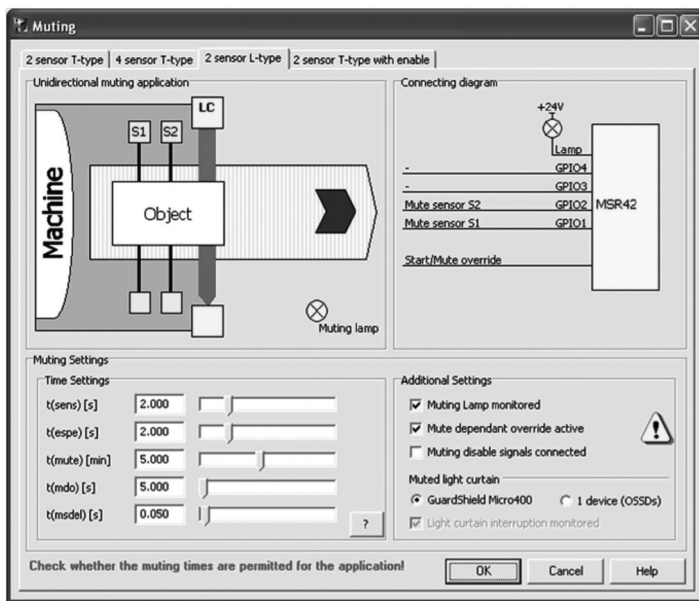

Figure 65: Configuration window for “two sensor L-type”

A time $t(\text{sense})$ of 4 s is recommended in the standard IEC 62046

Figure 66 shows the corresponding wiring diagram of the MSR42 control unit configured with the “two sensor L-type” muting mode.

For this muting mode two mute disable inputs may be configured. If selected these signals must be “high” in order for a mute condition to take place (See chapter 5.6.7 on page 39).

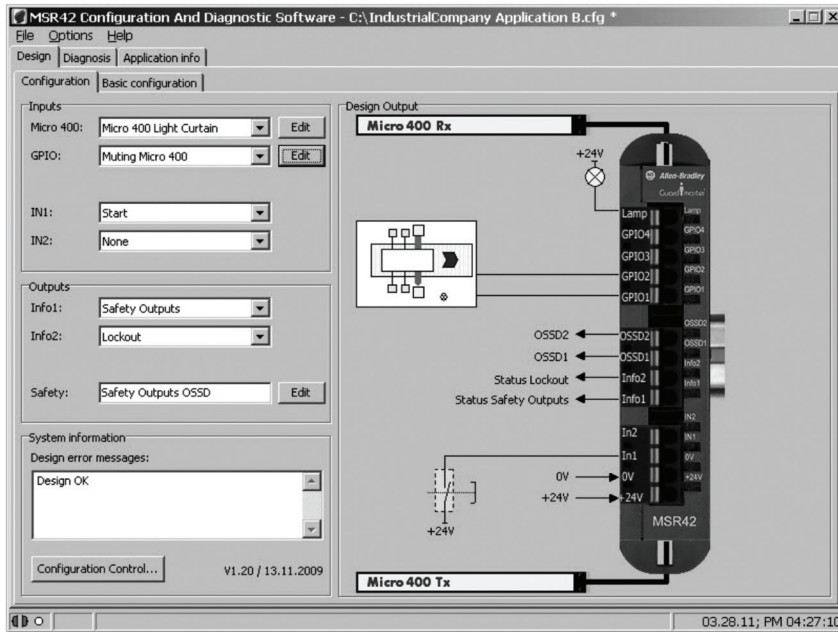

Figure 66: Wiring diagram “two sensor L-type” muting

5.6.13. Setup: two sensor T-type with enable signal

Figure 67 shows a schematic arrangement for two sensor T-type with enable signal muting. Only the Micro 400 can be configured for two sensor T-type with enable signal muting.

This version of muting is suited for applications when muting should only be possible at certain times; for example only when a conveyor is running. It should also be considered when the size and position of the pallet load is irregular or the size of the pallet is much smaller than the width of the conveyor. Since only one optical sensor is on either side of the light curtain, this mode requires an additional enable signal in order to initiate the muting sequence (e.g. a conveyor run signal). This signal S3 must be “low” before muting can be initiated.

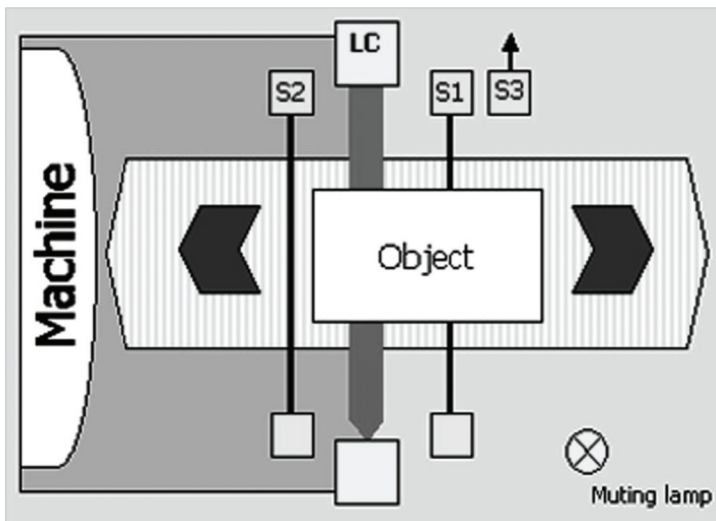

Figure 67: Example, “two sensor (S1 and S2) with enable signal (S3),” muting

The height of the two muting sensors should be at the same level as or higher than, the lowest beam of the light curtain.

The distance between S1 or S2 sensors to the light curtain should be sufficient so that they cannot be activated simultaneously by a person’s leg (> 250 mm).

It should not be possible for a person to pass undetected to the left or right of the object during the muting process.

IMPORTANT

A detailed description about muting, muting restrictions as well as hints for the installation are given in the standard IEC 62046. Additional hints are mentioned in the attachment A7 of IEC 61496-1.

Figure 68 shows the corresponding timing sequence for such an arrangement.

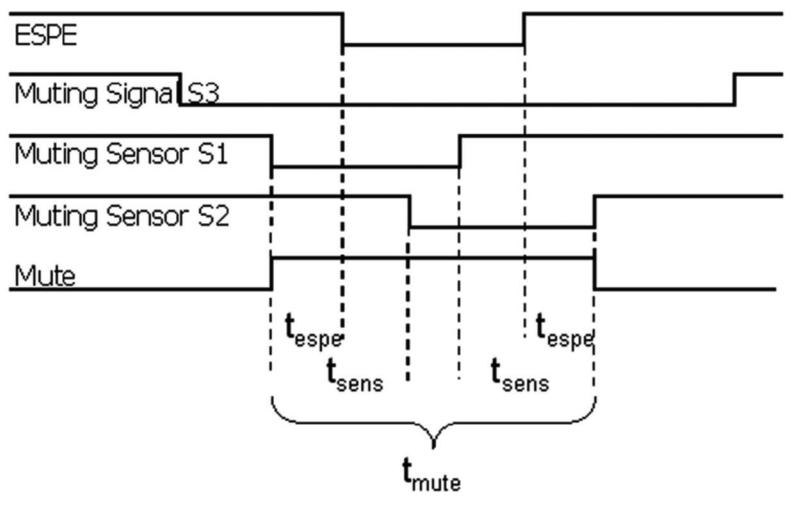

Figure 68: Timing sequence for “two sensor T-type with enable signal” muting

Muting of the Micro 400 light curtain is active only when both enable signal S3 and sensor S1 or enable signal S3 and sensor S2 are active. The muted condition will remain only if muting sensor S1 and S2 are activated within the specified time $t(sens)$. The muted condition will stop once either S3 or “S1 and S2” are no longer activated or the maximum muting time $t(mute)$ is exceeded (muting time out).

Only after one muting sequence is finished may a new muting sequence be started. The enable signal S3, must first go “high” before returning to “low,” in order for a second object to pass through the light curtain (equivalent to a conveyor stop and restart).

The following parameters can be configured in the configuration window (Figure 69) for “two sensor T-type w/enable signal” muting.

Parameter	Default Value	Max./Min. Values	Possible Settings
T(sens) [Figure 68]	4 s	Min.: 50 ms Max.: 10 s	N x 0.05 s
T(mute) [Figure 68]	5 min	Min.: 0 ms Max.: 10 days	(*)
T(msdel) [5.6.5]	50 ms	Min.: 0 ms Max.: 2.55 s	N x 0.01 s
Muting lamp monitoring [5.6.2]	yes		yes/no
Mute dependant override [5.6.4]	yes		yes / no
T(mdo) [5.6.4]	5 s	Min.: 0 Max.: 20 min	N x 5 s
Mute disable signal [5.6.7]	no		yes / no
Micro 400 interruption monitoring [5.6.8]	no		yes / no
T(espe) [5.6.8]	5s	Min.: 0 s Max.: 10 s	N x 0.05 s (*)

Table 4 (* = a setting smaller or close to the total response time may influence the stability of the muting system)

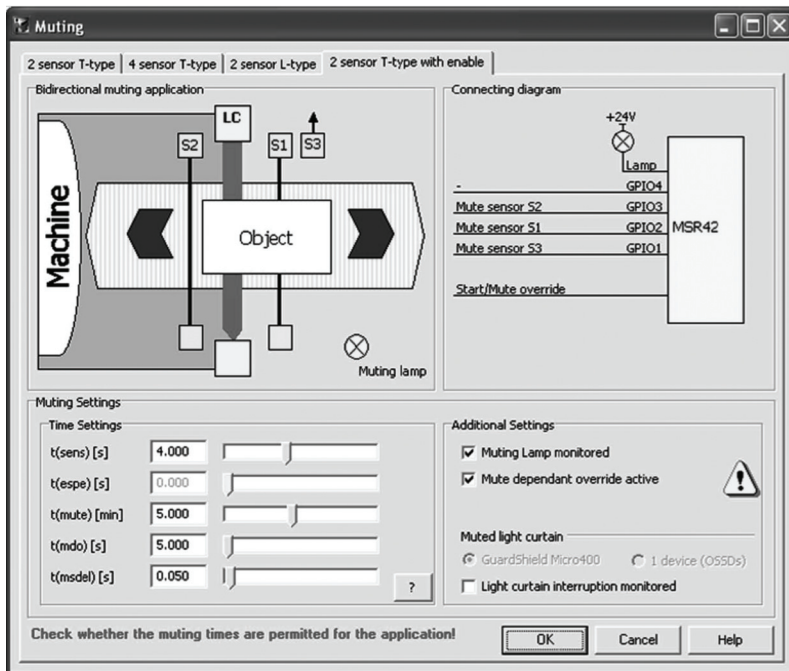

Figure 69: Configuration window for “two sensor T-type w/enable signal” muting

Figure 70 shows the corresponding wiring diagram of the MSR42 control unit configured with “two sensor T-type w/enable signal” muting mode.

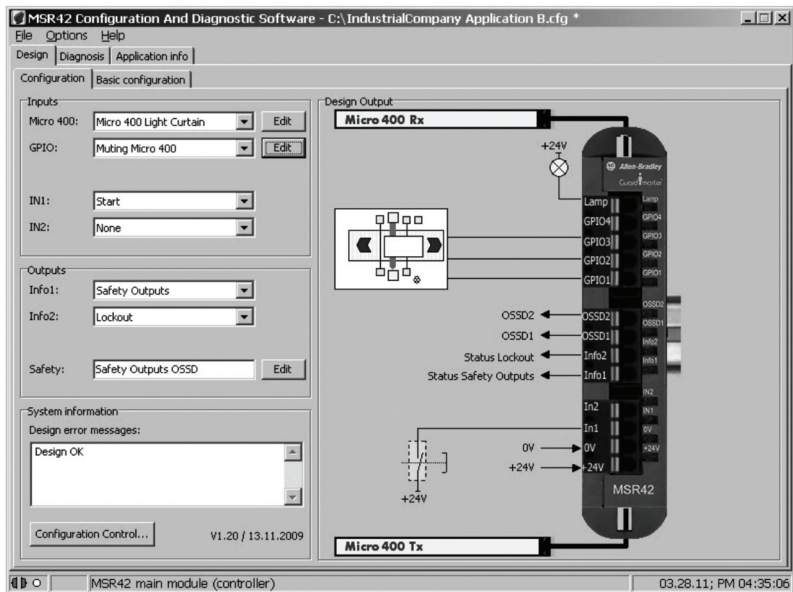

Figure 70: Wiring diagram for “two sensor T-type w/enable signal” muting

5.7. Blanking

Generally, “Blanking” is understood to mean ignoring the interruption of specific beams within a light curtain. Certain applications cannot be protected in any other way. If, for example normal operation of a machine requires that material be permanently fed into the dangerous part of a machine, then a portion of the protective field will always be interrupted, but the machine should nevertheless continue to operate. The protection with Blanking must come from a detailed risk analysis. Those responsible must ensure that in spite of Blanking, the safety of the machine operator is adequately accounted for. When necessary, additional protective measures must be taken to adequately shield the dangerous area. All Blanking modes create “holes” in the protective field. These “holes” must be considered separately in the risk analysis.

With the MSR42 Configuration and Diagnostic Software Tool, the three most important Blanking modes can be configured for the GuardShield Micro 400 safety light curtain.

Mode	Monitoring	Beam tolerance	Explanation
Teach In Blanking	With	+0/-1 beam (*)	One object, constant number of beams, at one defined location
Fixed Blanking	With	+0/-1 beam (*)	One object, constant number of beams, at one defined location
Floating Blanking	With	+0/-1 beam (*)	One object, constant number of beams, anywhere within the defined blanking region.
	Without	+0/-max. beams (*)	One object, up to the maximum number of beams, anywhere within the defined blanking region.

Table 5: Blanking modes (*= tolerance is reduced to +/- 0 beams when one beam is “teach-in” or configured)

It is possible to define different blanking regions with different blanking modes within one light curtain (5.7.4).

The following general rules must be understood:

- Different Blanking regions may not overlap.
- Regions without a Blanking mode, also with standard safety, will automatically be configured.
- Each configured region must be confirmed with the “Quick check” button, before the configuration of the next region can take place.
- The calculation of a new response time and a new resolution occurs after the “Quick check” confirmation.
- The maximum object size without detection is also calculated after the “Quick check” confirmation.
- After a successful configuration, the Blanking function will only be active when a Blanking lamp is attached. The Blanking lamp must be mounted near the protective field, clearly visible to the operator
- A configured Blanking function is visible on the MSR42 controller through the LED “Lamp”
- After a successful teach-in, the Blanking function will only be active when a Blanking lamp is attached.

Important safety notice:

The operator must ensure that for all Blanking modes, no undetected access is possible into the danger zone via the "blanked" protective field throughout the whole width of the protective field (also left and right of the "blanked" object). This can be achieved, for example, through the use of additional mechanical barriers (*Figure 71*)

Additionally, the blanked region should be clearly marked, and the protective field should be fully tested with the provided test rods according to the instructions given in the Micro 400 user manual.



Figure 71: Typical example of "Fixed Blanking"

5.7.1. Teach-in Blanking mode

Teach-in blanking is a version of fixed blanking (See chapter 5.7.2 on page 51), which detects objects that permanently interrupt the protective field. For Teach-in blanking, a key switch is used to "learn" which beams are interrupted. This mode is always "with monitoring", which means that the objects causing the interruption must remain in this position, otherwise the MSR42 safety outputs will switch off. Due to vibrations often present in industrial applications, the number of physically interrupted beams is allowed to be 1 less than the taught in number.

With this mode a blanking lamp must always be attached. This lamp has a dual function in that it confirms that a teach-in process has been successful.

Notice:

One or two objects positioned anywhere within the light curtain will be detected and "learned" during this Teach-in process. For each object at least two adjacent beams must be interrupted.

5.7.2. Fixed Blanking mode

Fixed Blanking is understood to be a continuous interruption of a defined number of adjacent beams, at one specified location in the protective field. For all other beams, normal safety operation is active. Only the specified beams need to be blanked, i.e. the blanking of the protective area will be constantly monitored (i.e. "with monitoring"). Due to vibrations often present in industrial applications, the number of physically interrupted beams is allowed to be 1 less than the specified number of beams. A local adjustment of this "tolerance" value is not possible (*Table 5*).

Example:

A 14mm resolution Micro 400 light curtain has 60 beams, which means a protective height of 600 mm. In this example, beam numbers 10 to 15 (6 beams) will be continuously interrupted. In this case Fixed Blanking is configured for beams 10 to 15. It is not allowed for beams 11 to 16, nor 9 to 14 to be interrupted. If they are interrupted the MSR42 safety output will switch off. However it is allowed for the beams 10 to 14 (five beams), or 11 to 15 (five beams) to be interrupted, and the safety outputs will remain ON. The following condition would also not be allowed

- Beam 10 to 12 interrupted
- Beam 13 not interrupted
- Beam 14 and 15 interrupted

A typical example of fixed Blanking is the exit ramp on an automatic punch press. The punched part is transported out of the dangerous zone into a container. The ramp passes through the protective field, and without "Blanking" would cause the machine to stop. The position of this ramp is monitored. During a tool change, the position of this ramp might vary slightly. This new position may need to be newly configured in order for the application to run smoothly.

Important safety notice:

For all Blanking modes, the user must ensure that no undetected entry into the dangerous area is possible through the blanked area of the protective field (i.e. left and right of the object being blanked). This can be achieved for example by mounting additional mechanical barriers (*Figure 71*).

Important safety notice:

Additionally, the blanked region should be clearly marked, and the protective field should be fully tested with the provided test rods according to the instructions given in the MSR42 user manual. The user should ensure that the number of blanked beams (i.e. the size of the object interrupting the protective field) will not be reduced during operation. If this is not possible, there is a risk that the resolution, at the edge of the "Fixed Blanking" area will be increased by 10 mm for a light curtain with 14 mm resolution and 25mm for a light curtain with 30mm resolution. This must be considered when calculating the safety distance.

5.7.3. Floating Blanking mode

Floating Blanking is understood to be an interruption of a certain number of beams (adjacent) anywhere in the protective field. The specified number of interrupted beams may not be exceeded. If they are exceeded the MSR42 safety output will switch off. The blanked area(s) may move throughout a defined region of the light curtain. The remaining beams within this region maintain their normal safety operation.

According to safety regulations, two floating Blanking modes are permitted: "with monitoring" and "without monitoring".

"With monitoring" means that the specified number of interrupted beams must be located next to each other and are always interrupted. If they are not interrupted the MSR42 safety output will switch off. Due to vibrations often present in industrial applications, the number of physically interrupted beams in this mode is allowed to be 1 less than the specified number of beams. A local adjustment of this "tolerance" value is not possible ([Table S](#)).

"Without monitoring" means that the specified number of interrupted beams may be interrupted, but do not have to be. For Floating Blanking "without monitoring", the specified number of interrupted beams do not have to be located next to each other.

Example:

A Micro 400 light curtain has 60 beams, which for a 14 mm resolution light curtain, means 600 mm protective height. In one application with monitoring, an object must interrupt six adjacent beams, somewhere within the specified protective field region. The process requires that the object interrupting the light beams, can move around throughout the protective field. At one point in time, beams 10 to 15 are interrupted, and at another point in time, beams 20 to 25 are interrupted. Due to this movement, Fixed Blanking is not acceptable.

If in this example, if beams 10 to 15 and beam 20 were interrupted, this would not be permitted and the MSR42 safety output will switch off.

The following condition would also not be allowed:

- Beam 10 to 12 interrupted
- Beam 13 not interrupted
- Beam 14 to 15 interrupted

This is because the interrupted beams are not adjacent to each other.

Typical application examples for "Floating Blanking" are applications where the transport of material occurs between the working area and the dangerous area, e.g. a roll of metal sheeting that is fed into a punch press, and depending on the position of the roll will interrupt a different area of the protective field ([Figure 72](#)).



Figure 72: Typical application of "Floating Blanking" with "monitoring"

Important safety notice:

During "Floating Blanking without monitoring", protective field "holes" can occur. This means at times when no material or insufficient material is being transported through the protective field, there is a danger that the operator can reach through the protective field without deactivating the machine.

5.7.4. Combining Blanking modes

The protective field of a single Micro 400 light curtain may be split up and configured into different regions. From a safety technical point of view, it is especially critical that the resolution is inspected at the cross over point from one protective field region to the next, as well as the borders or edges of each region. The MSR42 Configuration Tool takes into account these cross over areas when calculating the resolution and provides, as a result, the largest (resolution) for the complete light curtain system.

5.7.5. Indication of Blanking

If Blanking is configured then a lamp must clearly indicate this to the operator. The MSR42 Basic Configuration unit monitors the connection of a Blanking lamp. If this lamp is defective or not connected, the MSR42 controller will immediately cancel the blanking function and return to the standard safety mode (see also: MSR42 user manual).

However, depending on the risk analysis of the application, the monitoring of the indication lamp may be deactivated (#6 [Figure 74](#)). Even when deactivated, a connected lamp will still function if blanking is configured, but it will no longer be monitored.

Hint: for teach-in blanking a lamp is always required.

Important safety notice:

The Blanking lamp must be mounted near the protective field, clearly visible to the operator.

5.7.6. Activating blanking

The descriptions above explain in detail what the differences are between the three Blanking modes.

- Fixed Blanking
- Floating Blanking
- Teach-in Blanking

Fixed blanking and Floating blanking can be activated by downloading the configuration into the MSR42 controller. Teach-in blanking can be activated with the Basic Configuration ([See chapter 5.4.1.2 on page 20](#)), or by downloading a configuration with this function active into the MSR42 controller.

The light curtain protective field may be divided into one to three different regions, whereby each region may be configured independently with Fixed or Floating blanking. Teach-in blanking may only be used for one region: the entire light curtain protective field. When using Teach-in blanking, one or two different objects may be detected and blanked.

Important safety notice:

The configuration of Blanking will lead to longer reaction times, and possibly also to higher resolutions. These changes must be taken into account when calculating the minimum safety distance. The new response time, as well as a possible new resolution, will be shown in the Configuration Control Document.

Important safety notice:

After the Blanking configuration has been carried out, the user is responsible for testing the resolution of the light curtain. The blanked region should be clearly marked, and the protective field should be fully tested with test rods according to the instructions given in the Micro 400 user manual.

5.7.7. Configuring the Blanking Function

The blanking function is accessed from the Micro 400 window by selecting the blanking 'Edit' button ([Figure 33](#)).

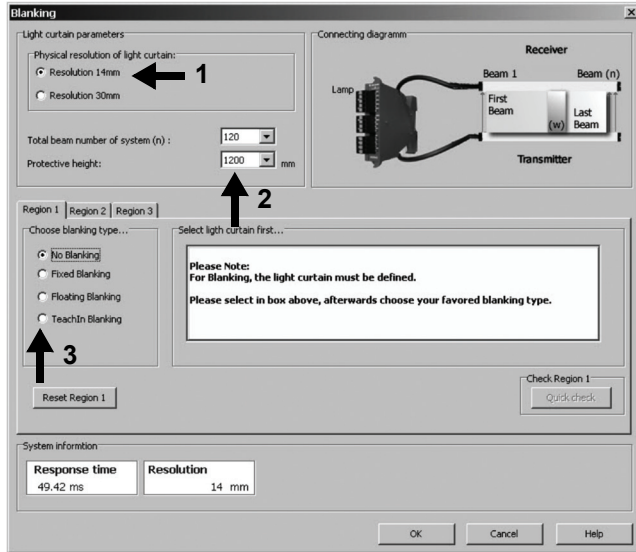

Figure 73: Blanking window

The first step is to define the resolution (1 *Figure 73*) and the number of beams or the protective field length of the Micro 400 light curtain (2). The length of the protective field as well as the physical resolution can be found on the specification label of the light curtain being configured.

Up to three regions may be configured with a different blanking mode for each region using the tabs Region 1, Region 2 and Region 3. Once the Blanking mode for a Region has been fully defined, the "Quick Check" box must always be clicked on, before moving on to the next region. With this step the user will receive confirmation that the entered data is correct.

Important safety notice:

With the "Quick check", the new response time as well as the new resolution of the safety light curtain will be displayed. These new values must be taken into consideration when calculating the safety distance as well as the mounting position of the safety light curtain. After a new configuration, the person responsible for the machine must test the resolution in order to eliminate dangers attributed to possible inactive zones or insufficient resolution.

Independent of which blanking mode has been chosen; the configuration must be finally confirmed by setting the "Blanking active" box in the additional features area of the Micro 400 window (*Figure 33*). Only then will the configured Blanking function be acknowledged.

Fixed Blanking

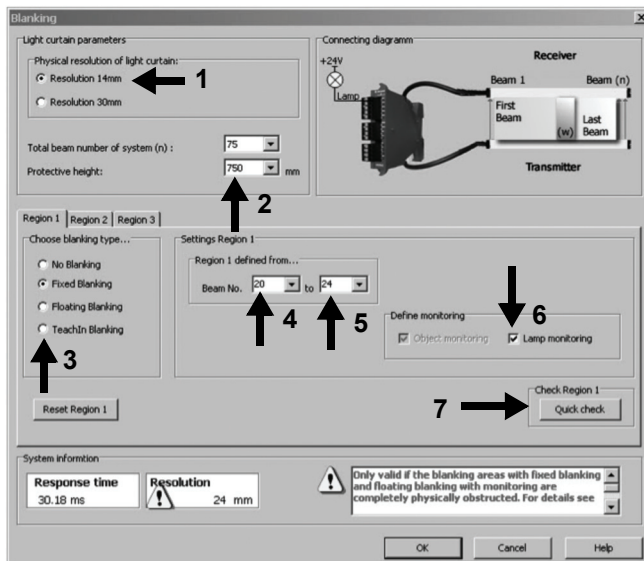

Figure 74: Fixed Blanking window

In the case of "Fixed Blanking" (3 – [Figure 74](#)), the first (4) and last (5) interrupted beams must be defined and thereafter confirmed with a cursor click on the "Quick check" box (7).

Floating Blanking

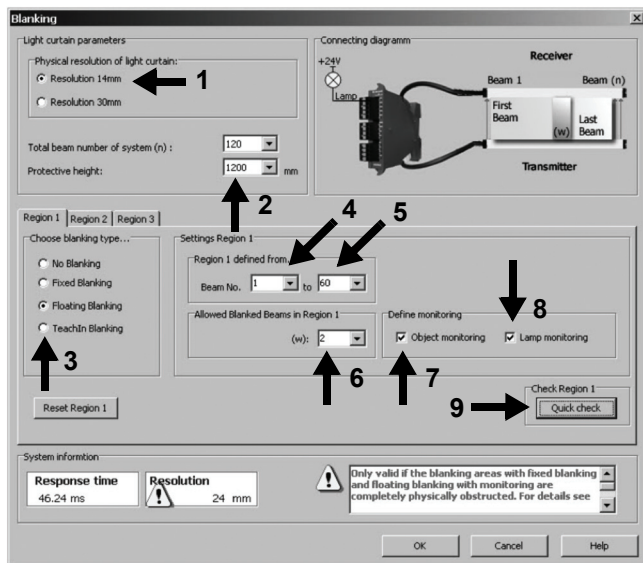

Figure 75: Floating Blanking window

In the case of "Floating Blanking" (3 – [Figure 75](#)), the area in which the object is allowed to move must first be defined (4 and 5). Subsequently the number of interrupted beams for "Floating Blanking" can then be defined (6). Finally, the user must specify whether this application operates with object monitoring or without object monitoring (7). Finish the blanking configuration for this region by clicking on the Quick check button. Additional information on floating blanking can be found in [chapter 5.7.3 on page 52](#).

Teach-in Blanking

Teach-In blanking is available in the Basic Configuration mode ([See chapter 5.4.1.2 on page 20](#)), and does not need to be configured. However if desired this mode can also be configured (3 – [Figure 73](#)).

6. Appendix

6.1. Frequently Asked Questions (FAQ)

Behavior	Possible Cause	Possible Solution
Download is not possible	Optical Interface is not connected	Connect Optical Interface (Cat. no. 445L-AF6150) to a USB port of your computer (See chapter 3 on page 8)
	USB driver not correctly installed	1. Unplug Optical Interface from USB port 2. Deinstall Configuration SW 3. Reinstall Configuration SW 4. Plug in Optical Interface on a USB port
	MSR42 is password protected	Contact the machine manufacturer (See chapter 5.5.3 on page 35)
Invalid Unit Protection Key (Error 403)	MSR42 is password protected	Contact the machine manufacturer (See chapter 5.5.3 on page 35)

Technical Support / Technische Unterstützung / Assistance technique / Assistenza tecnica / Asistencia técnica

ENGLISH	Installation of this product must not take place until the installer has obtained a copy of the manufacturer's instructions in a language which he can understand. This instruction sheet is available in multiple languages at http://rockwellautomation.com/literature .
DEUTSCH	Dieses Produkt darf erst installiert werden, wenn der Installateur eine Kopie der Instruktionen des Herstellers in der Sprache eingeholt hat, die er versteht. Diese Instruktionen sind mehrsprachig erhältlich unter: http://rockwellautomation.com/literature .
FRANÇAIS	Ce produit ne peut être installé avant l'obtention d'un duplicata des instructions du fabricant dans une langue compréhensible. La fiche d'instructions est disponible en plusieurs langues depuis le lien http://rockwellautomation.com/literature .
ITALIANO	Non si deve procedere all'installazione di questo prodotto fin quando l'installatore non abbia ottenuto una copia delle istruzioni del produttore in una lingua che l'installatore possa capire. La presente scheda di istruzioni è disponibile in linguaggi multipli sul sito web http://rockwellautomation.com/literature .
ESPAÑOL	Absténgase de instalar este producto a menos que el instalador disponga de un ejemplar de las instrucciones del fabricante en un idioma que pueda comprender. En http://rockwellautomation.com/literature puede encontrar esta hoja de instrucciones en varios idiomas.
PORTUGUÊS	A instalação deste produto não pode ser efectuada até que o montador tenha obtido uma cópia das instruções do fabricante numa língua que ele compreenda. Essa folha de instruções está disponível em diversas línguas em http://rockwellautomation.com/literature .
POLSKI	Nie należy przeprowadzać instalacji tego produktu aż do otrzymania przez monter instrukcji producenta w języku, który on rozumie. Te karty z instrukcjami są dostępne w wielu językach na: http://rockwellautomation.com/literature .
ČESKY	Instalace tohoto výrobku nesmí proběhnout, dokud instalující osoba neobdrží pokyny výrobce v jazyce, kterému rozumí. Tyto pokyny jsou k dispozici v několika jazycích na http://rockwellautomation.com/literature .
SVENSKA	Denna produkt får inte installeras förrän installatören har skaffat ett exemplar av tillverkarens instruktioner på ett språk som han/hon förstår. Detta instruktionsblad finns på flera språk på http://rockwellautomation.com/literature .
NEDERLANDS	Het product mag pas worden geïnstalleerd wanneer de monteur beschikt over een exemplaar van de instructies van de fabrikant in een voor hem begrijpelijke taal. Dit instructieblad is in diverse talen verkrijgbaar op http://rockwellautomation.com/literature .
繁體中文	安裝者須取得其所通曉語言之產品說明書後方可進行本產品的安裝。各語言版本的產品說明書可透過以下連結獲取: http://rockwellautomation.com/literature 。
简体中文	安裝者須取得其所通曉語言的產品說明書後方可進行本產品的安裝。各語言版本的產品說明書可通過以下連結獲取: http://rockwellautomation.com/literature 。
日本語	この製品の取付けは取付け者が理解できる言語で書かれたメーカーの取扱説明書を入手するまで行わないで下さい。この説明書は http://rockwellautomation.com/literature で複数の言語で提供されています
БЪЛГАРСКИ	Това устройство не трябва да се монтира, докато монтажника не разполага с инструкциите на производителя, на разбираем за него език. Инструкциите за монтаж ще намерите на различни езици в http://rockwellautomation.com/literature .
EESTI	Selle toote installatsioon ei tohi toimuda enne kui installeerija on omandanud koopia tootja instruksioonidega keeles mida ta ise valdab. Instruksioonid erinevates keeltes on saadaval siin: http://rockwellautomation.com/literature .
SUOMI	Tämä tuote voidaan asentaa vasta kun asentaja on hankkinut valmistajan ohjeet kielellä, jota hän ymmärtää. Erikieliset ohjeet ovat ladattavissa sivustolta http://rockwellautomation.com/literature .
ΕΛΛΗΝΙΚΑ	Εγκατάσταση του προϊόντος αυτού δεν πρέπει να γίνει πριν ο εγκαταστάτης προμηθευθεί αντίτυπο οδηγιών του κατασκευαστή σε γλώσσα που ο ίδιος καταλαβαίνει. Το εγχειρίδιο αυτό διατίθεται σε διάφορες γλώσσες στη διεύθυνση http://rockwellautomation.com/literature .
MAGYAR	Ez a termék csak akkor helyezhető üzembe, ha az üzembehelyezést végző személy rendelkezésére áll a gyártó használati utasítása az általa ismert nyelven. Az utasítás több nyelven megtalálható itt: http://rockwellautomation.com/literature
ÍSLENSKA	Uppsetning á þessari vöru má ekki eiga sér stað fyrr en sá sem annast uppsetninguna hefur fengið afrit af leiðbeiningum framleiðanda á því tungumáli sem hann þekkir. Leiðbeiningarþessi er tiltækur á mörgum tungumálum og er hægt að ná í hann hér: http://rockwellautomation.com/literature
LATVIEŠU VALODA	Šī ražojuma uzstādīšanu nedrīkst veikt, pirms uzstādītājs nav saņēmis ražotāja instrukcijas tādā valodā ko viņš saprot. Šo instrukciju lapīņu var saņemt daudzās valodās no vietnes http://rockwellautomation.com/literature
LIETUVIŠKAI	Šito produkto įrengimas negali būti vykdomas tol, kol įrengėjas neturės gamintojo instrukcijų kopijos ta kalba, kurią jis supranta. Instrukciją galima rasti įvairiomis kalbomis tinklapyje http://rockwellautomation.com/literature
MALTI	L-installazzjoni ta' dan il-prodott mgħandux isir qabel ma l-installatur jakwista kopja tal-istruzzjonijiet tal-manifattur f'lingwa li tista' tiftiehem. Il-karta tal-istruzzjonijiet hija disponibbli f'hafna lingwi f' http://rockwellautomation.com/literature .
NORSK	Dette produktet må ikke installeres før installatøren har bruksanvisningen på et behersket språk. Dette instruksjonsarket kan fås i flere språk på http://rockwellautomation.com/literature .
ROMÂNĂ	Produsul nu trebuie să fie instalat până când cel care instalează produsul nu a obținut o copie a manualului de utilizare, în limba pe care o poate înțelege. Aceste instrucțiuni sunt valabile în mai multe limbi la adresa http://rockwellautomation.com/literature .
SLOVENSKY	Inštalácia tohto výrobku nesmie prebehnúť, dokiaľ inštalujúca osoba nedostane pokyny výrobcu v jazyku ktorému rozumie. Tieto pokyny sú k dispozícii v niekoľkých jazykoch na http://rockwellautomation.com/literature .
SLOVENŠČINA	Tega izdelka se ne sme nameščati, če si oseba, ki ga namešča, ni priskrbela izvoda proizvajalčevih navodil v jeziku, ki ga razume. Ta list z navodili v številnih jezikih je na razpolago na http://rockwellautomation.com/literature .
TÜRKÇE	Bu ürünün kurulmasını, ürünü kuracak kişinin üreticinin hazırladığı talimatların bir kopyasını, ki bu talimatlar bu kişinin anlayacağı bir dille olacaktır, elde edene kadar gerçekleştirilmesi gerekir. Bu talimatlar pek çok dilde şu web-sayfasında mevcuttur: http://rockwellautomation.com/literature

GuardShield is a trademark of Rockwell Automation, Inc.
Guardmaster is a registered trademark of Rockwell Automation, Inc.

www.rockwellautomation.com

Power, Control and Information Solutions Headquarters

Americas: Rockwell Automation, 1201 South Second Street, Milwaukee, WI 53204 USA, Tel: (1) 414.382.2000, Fax: (1) 414.382.4444

Europe/Middle East/Africa: Rockwell Automation, Vorstlaan/Boulevard du Souverain 36, 1170 Brussels, Belgium, Tel: (32) 2 663 0600, Fax (32) 2 663 0640

Asia Pacific: Rockwell Automation, Level 14, Core F, Cyberport 3, 100 Cyberport Road, Hong Kong, Tel: (852) 2887 4788, Fax: (852) 2508 1846