

PCB3[®]

Two-hand

Control Desk



Index

Presentation PCB3®	4
Desks with machining and special colors	5
References	6
Specifications PCB3® y PRB05	7
Dimensions	9
Definitions and installation instructions	10
Maintenance and Inspection	11
Overview of the European Standard EN 574:1996.....	12
Annex B.....	14
CE Conformity.....	15

Presentation PCB3®

The Control requires at least a synchronous action by both hands to release and maintain the operation of a machine or machine elements as long as there are dangerous situations, assuring in this way only the protection of this operator.

PCB3/P



DESCRIPTION PCB3®

- Smelted-aluminum cover-part with a protection lid over each pushbutton.
- Available with reserved holes for additional pushbuttons of Ø22,5 mm (see Selection table of references).
- Delivered with an Ø20 mm ergonomic head tube made of polished stainless steel to facilitate the operation of the buttons from different positions.
- Bottom base cast aluminum with central opening of 200x90 mm for cables entries.
- Prepared to be mounted directly on adjustable metal foot PRB05.
- 2 mm thickness rubber sealing between base and cover to protect the terminals against dust, oil and water
- IP65 protection with supplied pushbuttons.
- Standard paint orange RAL 2003 (other versions on request).
- Weight: 5Kg.
- Standard paint orange RAL 2003 (other versions on request).

PUSHBUTTONS

PCB3/S



- **Two-hand control:**
2 black pushbuttons Ø60 mm (mushroom type) with contact block (1NO + 1NC).
- **Emergency Stop device**
1 red pushbutton Ø40 mm (mushroom type) with blocking device, push-turn for unlocking, contact block (2NC), delivered with Ø60 mm Emergency Stop label, yellow and English black letters (others languages under request).
- **Manufactures:**
Rockwell, (others manufactures under request).
- **4 PVC blockages**, black color and Ø22,5 mm with reserved holes option.

Desks with machining and special colors

On request is possible to provide units with special characteristics or factory preassembled

SPECIAL APLICATIONS



- Special painted.
- Special heights.
- Assembled additional pushbuttons, as switches, signaling lamps, selectors, etc.
- Safety foot control mounted.
- Units pre-wired
- Labels with texts in different languages, for example in emergency stop



Metal foot with adjustable height PRB05, for PCB3® installation

Adjustable feet can be used for PCB3® installation and for many other uses.

DESCRIPCIÓN PRB05



- Two telescopic tubes of $\varnothing 55$ and $\varnothing 60$ mm with a lever to fix the selected height angle and turn position.
- Two cable entries at bottom side and an $\varnothing 48$ mm PVC cone at the top to retain the cables.
- A plate of 200x90x3 mm on top side prepared to assemble the PCB3®, and lever for the inclination adjustment.
- A robust and stable base plate with two $\varnothing 10,5$ mm holes to fix the metal foot on the floor.
- The PRB05 base plate is prepared to accept two foot control unit.
- Steel made.
- Standard paint RAL2003 orange textured.
- Weight: 9,2 Kg.

References

Type	Emergency Stop	Control Pushbuttons	Accessories	Order Ref.
 PCB3/SS	1 drill hole of Ø22,5 mm	2 holes of Ø22,5 mm	-	PCB3/SS
 PCB3/S	1 red E-Stop Push Button Ø40 mm Mushroom type Push-turn for unlocking NC + NC	2 black E-Stop Push Button Ø60 mm Mushroom type NC + NA Slow double make and break	-	PCB3/S
 PCB3/N	1 drill hole of Ø22,5 mm	2 drill holes of Ø22,5 mm	4 drill holes with rubber plug of Ø22,5 mm	PCB3/N
 PCB3/P	1 red E-Stop Push Button Ø40 mm Mushroom Push-turn for unlocking NC + NC	2 black E-Stop Push Button Ø60 mm Mushroom type NC + NA. Slow double make and break	4 drill holes with rubber plug of Ø22,5 mm	PCB3/P
 PCB3/S-NE	1 red E-Stop Push Button Ø40 mm Mushroom type Push-turn for unlocking NC (pneumatic)	2 black E-Stop Push Button Ø40 mm Mushroom type NA (pneumatic)	Pneumatic control relay for two hand control EN574: type IIIA	PCB3/S-NE
 PCB3/P-NE	1 red E-Stop Push Button Ø40 mm Mushroom type Push-turn for unlocking NC (pneumatic)	2 black E-Stop Push Button Ø40 mm Mushroom type NA (pneumatic)	4 drill holes with rubber plug of Ø22,5 mm Pneumatic control relay for two hand control EN574 : type IIIA	PCB3/P-NE

Type	Base plate	Height (PCB3® installed)	Accessories	Order Ref.
 PRB05	435 x 360 x 6 mm	720 – 1170 mm	2 safety foot control (optional)	PRB05

Specifications PCB3®

Constructive		
Conformity	EN 574	
Materials	Body Bar Seal	Smelted Aluminum Stainless Steel (AISI 304) Rubber 2 mm
Weight	5 kg	
Color	Orange RAL 2003	
Dimensions	See page 9	
Electrical Shock Protection	IP 65	

Electrical pushbuttons (Rockwell 800FP series)		
		PCB3/S, PCB3/P
Certifications	CE	
Conformity	NEMA ICS-5, UL 508, EN ISO 13850, EN 60947-1, EN 60947-5-1, EN 60947-5-4, EN 60947-5-5	
Terminal identification	IEC 60947-1	
RoHS	Yes	
Mechanical durability	EN60947-5-1 (Annex C)	10.000.000 cycles
Operating forces	Emergency Stop	43N
	Control pushbuttons	13N
Temperature range	Operation storage	-25...+70°C (-13...158°F) -40...+85°C (-40...185°F)
Humidity	50...95% RH from 25...60°C (77...140°F)	
Standard contact block ratings	A600, Q600 600V AC AC 15, DC13 to IEC/EN 60947-5-1 and UL 508,17V, 5 mA min	
Thermal current	10 A max (40°C ambient) to UL508, EN 60947-5-1	
Insulation voltage	690V	
Wire capacity	0,75..2,5mm ² (#18...12 AWG)	
Recommended tightening torque	0,7...0,9Nm	
External short circuit protection	6 A type gL/gG cartridge fuse to EN 60269-2-1 or gN (Class J to UL 248-8 or Class C to UL 248-4)	
Electrical shock protection	IP2X (finger safe conformity)	
Contact operation	N.O. N.C.	Slow double make and brake Slow double make and brake – positive opening

Pneumatic pushbuttons (Airon NEUMATIC)		PCB3/S-NE, PCB3/P-NE
Certifications		CE
Conformity	Two-hand controller (Included)	EN 574: type IIIA
Working pressure		1 to 8 bar
Temperature range	Operation	-15...+60°C (5...140°F)
	Storage	-40...+85°C (-40...185°F)
Flow	ISO 6358	Qmax = 60 l/min Qn = 30 l/min
Connections		Ø4 mm straight Push-in
Activation force (at 6 bar)	Emergency Stop	49N
Activation force (at 6 bar)	Control pushbuttons	8,5N

Relevant aspects of security		
EN954-1		Cat. 4 (properly connected to a safety relay)
ISO 13849-1, ISO 13849-2:2003 IEC 62061	Emergency Stop Circuit	B10d=100000, nop=365* PL e, SIL 3, DCavg=99%, MTTFd=100 (High) PFH [1/h]=2,47E-8 (properly connected to a safety relay)
	Two hands control circuit	B10d=100000, nop=10512* PL e, SIL 3, DCavg=99%, MTTFd=100 (High) PFH [1/h]=4,93E-8 (properly connected to a safety relay)

* Data is based in the following numbers of operations:

1op/24 hrs, 24hrs/day, 365 days/year (Emergency Stop)
1op/50min., 24hrs/day, 365 days/year (Two hands control)

Specifications PRB05

Constructive		
Certifications		CE
Materials	Body	Steel
Weight		9,2 kg
Color		RAL 2003 Orange textured
Dimensions		See page 9

Dimensions

PCB3/.....

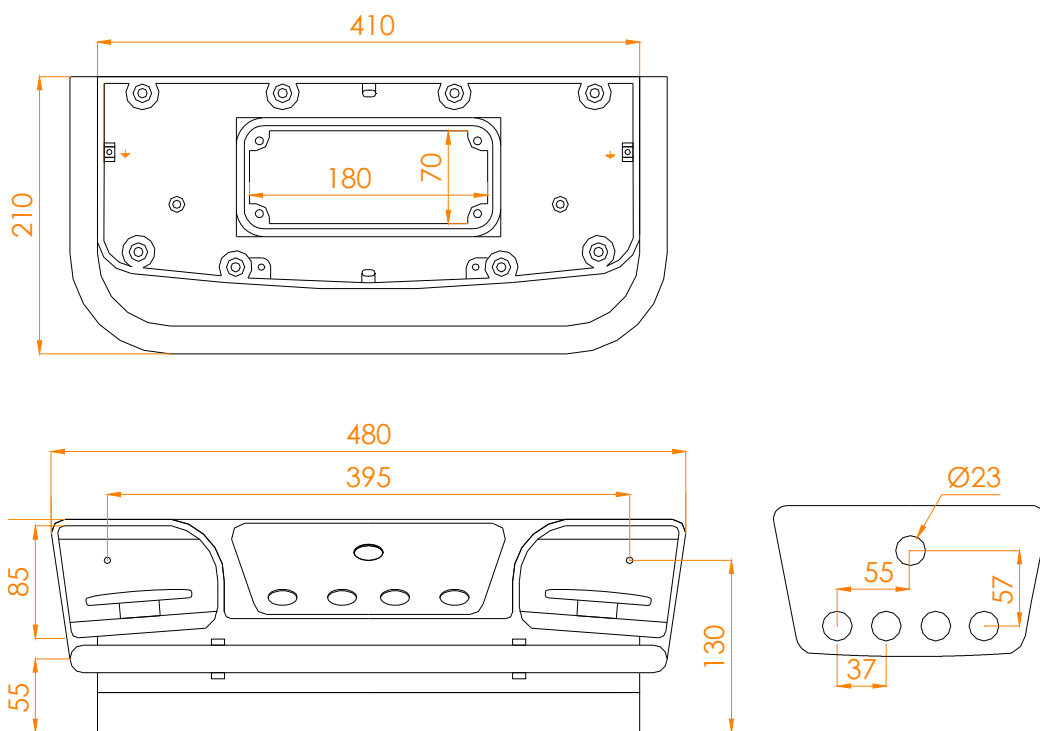

PRB05

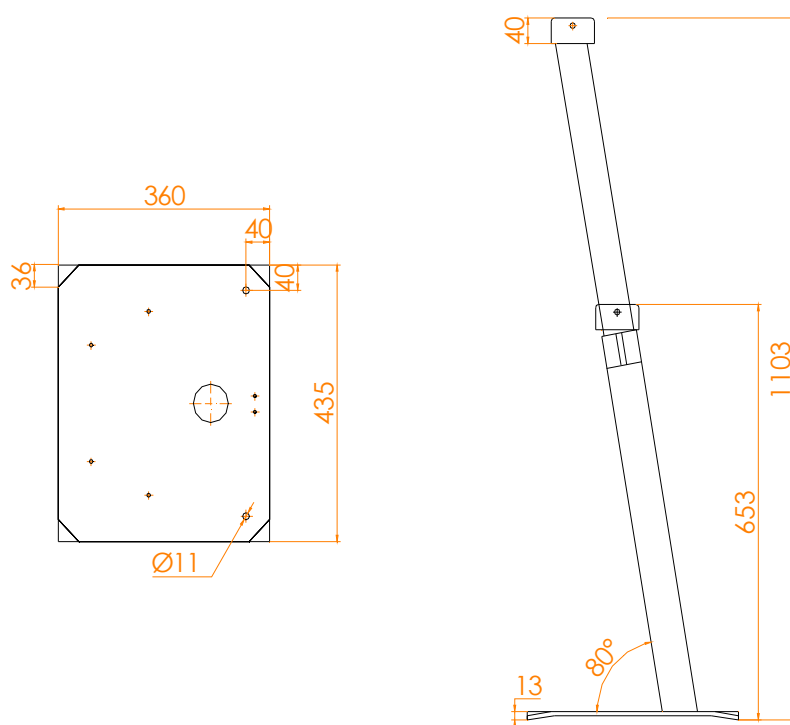

Definitions and installation instructions

Important

All related installation instructions are to be carefully followed and fully complied with in the way to obtain the accordance to EN574. Following relevant safety standard are to be taken into consideration by the installation of a two-hand control unit:

EN60204; EN292-1; EN292-2; EN574; EN954-1, EN954-2; prEN999.

The two-hand control desk must be connected to a certified safety device in accordance to EN574 chap. 3 and from type IIIC – category 4 in accordance to EN954-1 –2 (the logic block authorizes the start of the machine cycle only if both pushbuttons are actuated within a delay inferior or equal to 0,5 s).

- In the case of movable two-hand control desks it is necessary to take measures against movement of the desk during the operation.
- The minimum safety distance “S” is to be taken into consideration and must be calculated using the following general formula according to EN999:

General formula: $S = (K \times T) + C$ where:

S = minimum safety distance in mm,

K = approach speed of the body or a body limb (1.600 mm./s according to EN999),

T = (T1 + T2) Total reponse time (machine stop time) in seconds,

T1 = output Relay Release Time (Delay-on Energisation to EN574).

T2 = delay-time for machine stop or interruption of dangerous movement after delay time from safety module.

Example

The minimum safety distance between the dangerous zone and the closest pushbutton must be calculated using the following formula.

$S = (1.600 \text{ mm./s.} + T) + 250 \text{ mm.}$

In case that the risk of moving the body or a body limb towards the dangerous zone is limited while the protective devices is actuated, e.g. by means of an adequate screen, the value of C can be 0 with an acceptable minimum value of S = 100 mm.

Wiring

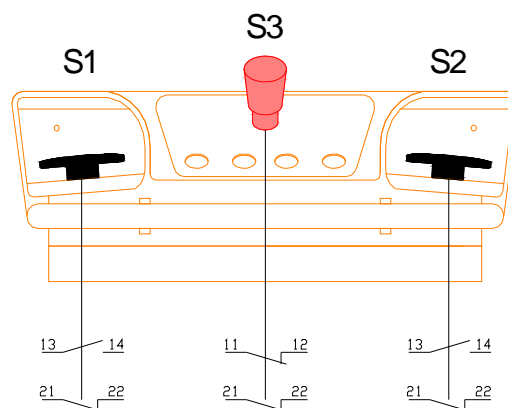

- The two-hand control unit and connection cables with a certified safety device have to be installed in a way to avoid influences from the severe mechanical loads. The system has to comply with EN954-1-2 and other specifications concerning environment conditions. We recommend multi-conductor cable with shield.
- The shield has to be connected to earth with one of his extremities. Connect the earth-terminal from the two-hand unit with the earth-terminal from electrical cabinet.
- In the case of two-hand control unit with emergency-stop button it is necessary to dissociate the electrical connection from emergency-stop and the electrical connection from the two-hand pushbuttons in passing them through different cables.
- Foresee cable glands at the cable entries to obtain a correct efficacy of the anti-twist protection.
- It is imperative to mount the certified safety control device in the control cupboard to avoid a false function (their outputs are not controlled).
- There are to install so many two-hand control desks as control places from the machine.



Example of “two-hands” control wiring

The following diagram shows the basic wiring of the activation pushbuttons S1 and S2 to a specific safety relay for control of the two-hands system. It is recommended to follow the manufacturer's safety relay for proper wiring.

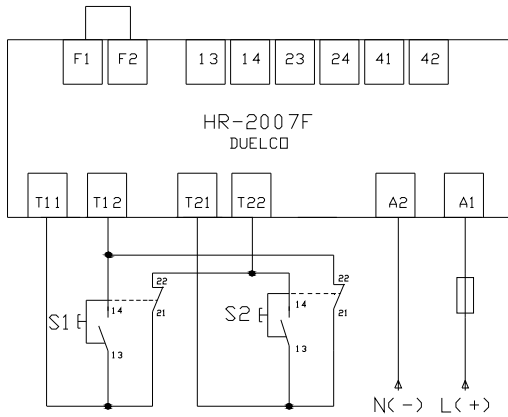

* Example of electrical wiring with a Duelco two-hand control relay HR-207, where it can get a category IIIC according to EN574, Cat.4 according to EN954-1 or PL e according to ISO 13849-1.

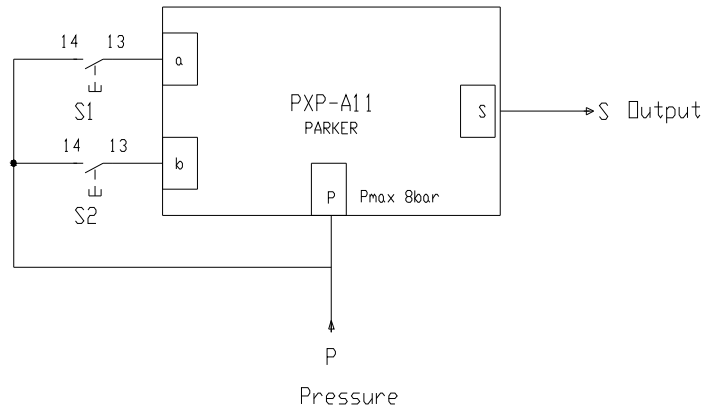

* Example of pneumatic wiring with a Parker two-hand control relay PXP-A11, where it can get a category IIIA according to EN574, Cat.4 according to EN954-1 or PL c according to ISO 13849-1.

Example of “Emergency Stop” control wiring

The following diagram shows the basic wiring of the Emergency Stop pushbutton S3 to a specific safety relay for control of the Emergency Stop system. It is recommended to follow the manufacturer's safety relay for proper wiring.

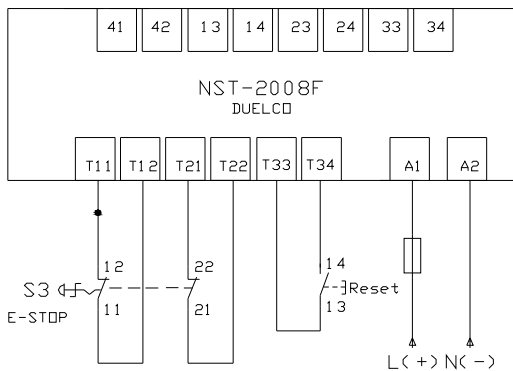

• Example of electrical wiring with a Duelco emergency Stop control relay NST-2008F, where it can get a Cat.4 according to EN954-1 or PL e according to ISO 13849-1.

Maintenance and Inspection

All security devices for persons shall be carefully tested and checked during the life cycle. The functions/elements to be tested are:

- Connecting cable between two-hand control desk an security device.
- Function of pushbuttons and contacts.
- Test and inspections of the protective device shall be carried out according to the current laws and regulations by qualified and trained persons.

Overview of the European Standard EN 574: 1996

Extracts: DIFFERENT TYPES OF TWO-HAND UNITS AND SELECTION

The following table shows the three types of two-hand units, their functions-features and the fundamental health & safety requirements from each type. The compliance with EN292 and the corresponding parts from EN60204-1 has to be achieved with the two-hand control units.

PRESCRIPTIONS	TYPE				
	I	II	III		
			A	B	C
Use of both hands (simultaneous action)	X	X	X	X	X
Link between input and output signal	X	X	X	X	X
Inhibiting the output signal	X	X	X	X	X
Prevention of accidental operation	X	X	X	X	X
Tamper-proof	X	X	X	X	X
Reiniciación de la señal de salida		X	X	X	X
Reinitialization of the output signal			X	X	X
Use of category 1 conforming to EN 954-1	X		X		
Use of category 3 conforming to EN954-1		X		X	
Use of category 4 conforming to EN 954-1					X

Extracts: Synchronous action

The output signal is only generated if both pushbuttons are activating within a delay lower or equal to 0,5 s.

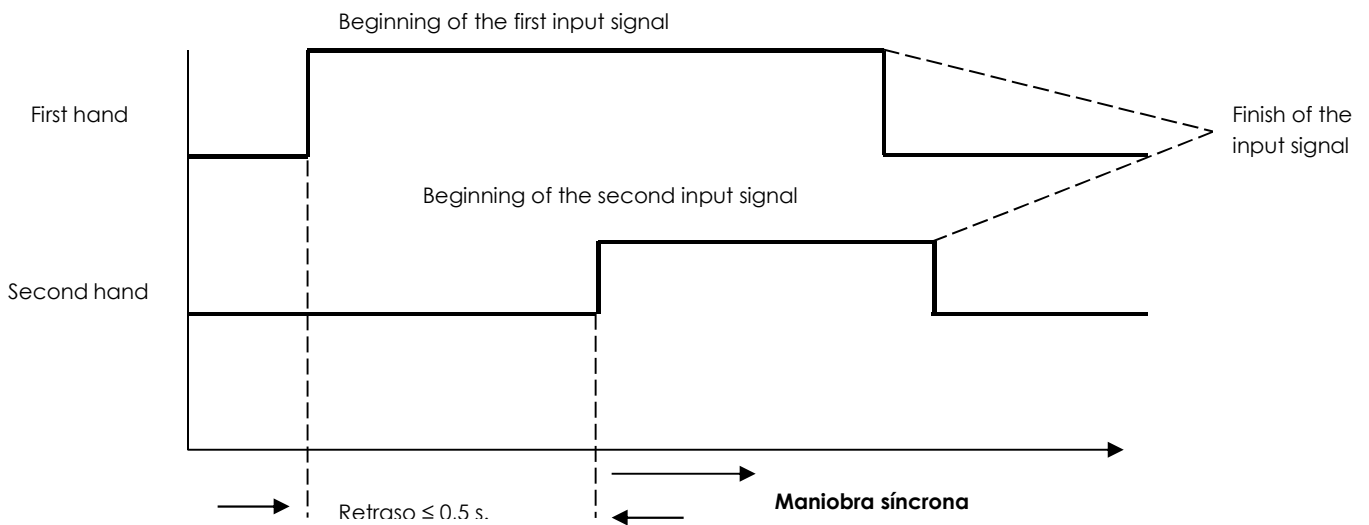

• Note: in case that two or more two-hand control units are used to operate a machine, the synchronous action is only required for each two-hand control unit, but not between the control units.

Extract: Protection against accidental operation and tampering

The pushbuttons of a two-hand control unit must be designed and positioned in a way that it is difficult to “tamper” with the protection offered by the two-hand control unit and to minimize the probability of accidental operation, conforming to the estimation of risk in the particular application.

The use of a single hand, the combination of one hand and/or other parts of the body, the use of simple auxiliary means that allow a tampering have to be taken into consideration in a way that it is impossible to reach the dangerous zone during a dangerous situation. An accidental operation (e.g. by the operator’s clothes) has to be taken into account in the same way.

• Tampering with a single hand

It is necessary to take measures against tampering with a single hand. Here below you will find examples of appropriate measures:

Distance between the pushbuttons (internal dimension) of at least 260 mm.

One or more screens designed in a way that the distance between the pushbuttons including obstacle of at least 260 mm.

• Tampering with one hand and the elbow of the same arm

It is necessary to take measures against tampering with one hand and the elbow of the same arm. Here below you will find examples of appropriate measures:

One or more screens designed in a way that the pushbuttons cannot be actuated with the elbow and the finger of the hand of the same arm.

Cover designed in a way that the pushbuttons cannot be actuated with the elbow.

• Tampering with one hand and other parts of the body (e.g. knee, hip)

It is necessary to take measures against tampering with one hand and other parts of the body. Here below you will find examples of appropriate measures:

Positioning of the two-hand control unit on a horizontal or almost horizontal surface situated at least 1100 mm above the ground or the access platform. This arrangement prevents the operation with the hip.

In case of installation on a vertical or almost vertical surface, mounting of a protective collar around the pushbuttons.

Covers and/or screens designed in a way that the pushbuttons cannot be actuated with one hand and another part of the body.

Indication:

The two hand control units PCB3® responds to these requirements to protect against accidental switching and neutralization long as all indications regarding installation and use are respected.

ANEX B (informative) of EN-574

DIFFERENTS TYPE OF TWO-HAND CONTROL UNITS AND THEIR CORRESPONDENCE WITH THE CATEGORIES ACCORDING TO 954-1

TABLE B.1

Category	Requirements	Type of two-hand control unit
B	Safety-related parts of machine controls and/or their safety equipment and components must be designed, selected, assembled and combined to state-of-the-art technological standards if they are to stand up to the influence which can be expected to affect them. Safety related parts of category B controls can be affected by loss of safety function when an error occurs. Some errors remain unidentified	
1	The requirements under category B apply initially. An additional requirement is the utilization of components and principles which have proven themselves in terms of safety-related technical performance. This leads to greater safety-related reliability. However, the occurrence of an error can lead to the loss of the safety function. Some errors remain unidentified.	I y IIIA
2	The requirements under category B apply, along with the utilization of principles which have proven themselves in terms of safety-related technical performance. Moreover, the safety functions should be checked at suitable intervals. Testing can be conducted automatically or manually, depends on the application and type of machine.	
3	The requirements under category B apply, along with the utilization of principles which have proven themselves in terms of safety-related technical performance, also apply here. Controls should also be designed so that a single error does not cause a general loss of safety function(s), and that the single error be identified by suitable means conforming with state-of-the-art technological standards (whenever this can be conducted in a suitable manner). The safety function in the safety-related parts of the category 3 controls is always retained if a single error occurs. Some, but not all, errors are identified. A build-up of unidentified errors can lead to a loss of safety function	II y IIIB
4	Controls must be designed so that a single error does not cause a general loss of safety function(s). A single error must be identified during or prior to the next requirement (whenever possible). If this is not possible, a build-up of errors should not lead to a loss of safety function Errors are identified on time in the safety-related parts of the category 4 control, thus preventing a loss of safety function, or the safety function is retained despite errors occurring	IIIC



CERTIFICADO DE CONFORMIDAD CE

CE – DECLARATION OF CONFORMITY

Nosotros

Star Automation, S.L.

We

Carrer de Can Ribas, 6 P. I. Congost

08520-Les Franqueses del Vallès (Barcelona)

Declaramos bajo nuestra propia responsabilidad que el producto

Declare under our own responsibility that the product

PCB3® - Pupitre de mando a dos manos

PCB3® - Two hand control desk

Es conforme a la norma europea EN 574

Conforms with the European standard EN 574

Marcaje CE: Mayo 2002

CE mark: May 2002

Les Franqueses del Vallès, 5 de mayo 2002

Juan Fernández (Gerente)

Distribuidor autorizado:



Carrer de Can Ribas, 6 Pol. Ind. Congost
08520- Les Franqueses del Vallès
Telf. +34 93 840 32 17 Fax +34 93 846 41 01
E-mail: info@starautomation.es
www.starautomation.es

Síguenos:

