

GuardShield™ PAC Type 4 (Perimeter Access Control) Safety Light Curtain User Manual

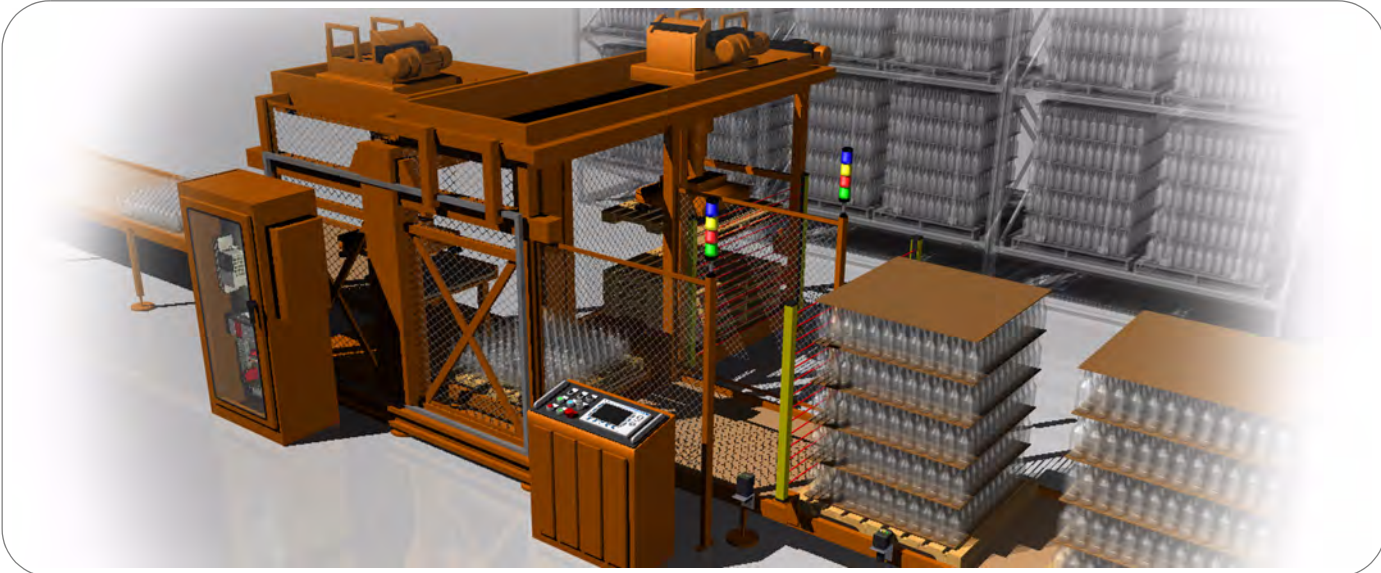

Important User Information

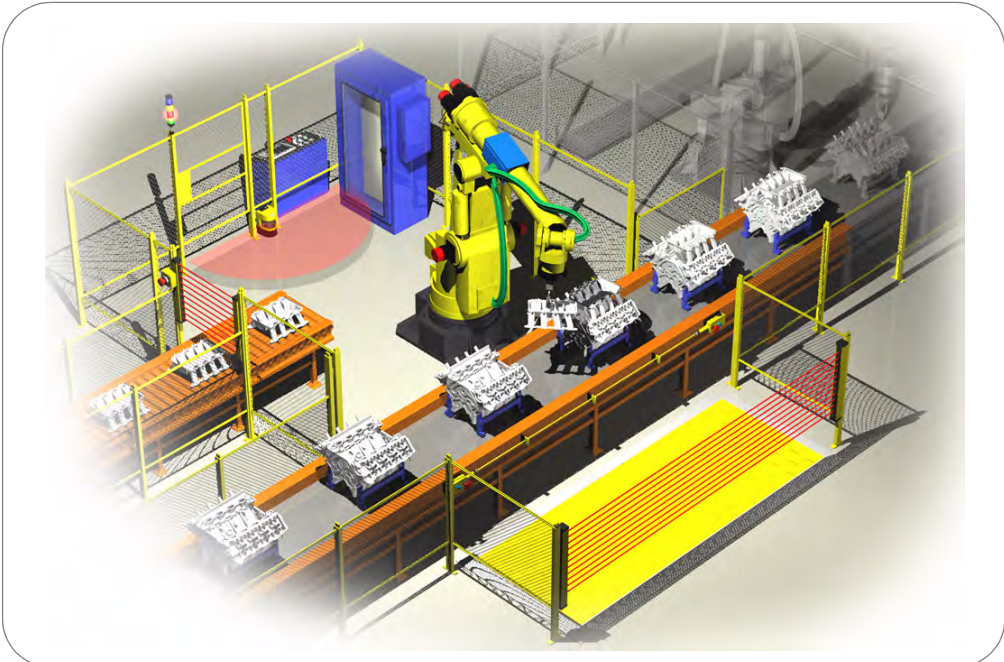

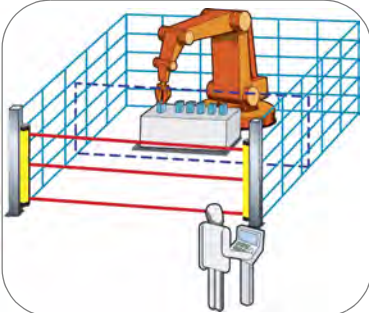
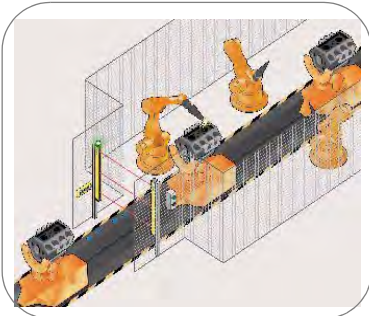

Because of the variety of uses for the products described in this publication, those responsible for the application and use of this control equipment must satisfy themselves that all necessary steps have been taken to assure that each application and use meets all performance and safety requirements, including any applicable laws, regulations, codes and standards.

The illustrations, charts, sample programs and layout examples shown in the guide are intended solely for purposes of example. Since there are many variables and requirements associated with any particular installation, Rockwell Automation does not assume responsibility or liability (to include intellectual property liability) for actual use based upon the examples shown in this publication.

Rockwell Automation publication SGI-1.1, Safety Guidelines for the Application, Installation and Maintenance of Solid-State Control (available from your local Rockwell Automation sales office), describes some important differences between solid-state equipment and electromechanical devices that should be taken into consideration when applying products such as those described in this publication.

Reproduction of the contents of this copyrighted publication, in whole or part, without written permission of Rockwell Automation, is prohibited.

Throughout this manual we use notes to make you aware of safety considerations:

WARNING 	Identifies information about practices or circumstances that can cause an explosion in a hazardous environment, which may lead to personal injury or death, property damage, or economic loss.
IMPORTANT	Identifies information that is critical for successful application and understanding of the product.
ATTENTION 	Identifies information about practices or circumstances that can lead to personal injury or death, property damage, or economic loss. Attentions help you identify a hazard, avoid a hazard, and recognize the consequences.
SHOCK HAZARD 	Labels may be on or inside the equipment (for example, drive or motor) to alert people that dangerous voltage may be present.
BURN HAZARD 	Labels may be on or inside the equipment (for example, drive or motor) to alert people that surfaces may reach dangerous temperatures.

It is recommended that you save this user manual for future use.

Conditions required for proper use of the GuardShield PAC Safety Light Curtain

Please make sure you read and understand these requirements before you select and install the GuardShield PAC safety light curtain. GuardShield PAC safety light curtains are perimeter access safeguarding devices. These safety light curtains are intended to be used to provide perimeter access safeguarding of personnel around a variety of machinery.

The GuardShield PAC family of safety light curtains are general purpose presence sensing devices which are designed to protect personnel working on or near machinery.

The installation of the GuardShield PAC safety light curtains must comply with all applicable federal, state, and local rules, regulations, and codes.

It is the responsibility of the employer to properly install, operate and maintain the product as well as the machinery on which the GuardShield PAC presence sensing device is installed.

GuardShield PAC safety light curtains must be properly installed by qualified personnel.

GuardShield PAC safety light curtains are presence sensing devices and will not protect personnel from heat, chemicals, or flying parts. They are intended to signal a stop of hazardous machine motion when the sensing field is broken.

GuardShield PAC safety light curtains can only be used on or around machinery which can be stopped anywhere in its stroke or cycle.

GuardShield PAC safety light curtains should never be used for guarding full revolution clutched machinery.

The effectiveness of the GuardShield PAC safety light curtains depend upon the integrity of the machine control circuit. The machinery that the GuardShield PAC presence sensing device is installed on should have control circuitry that is fail safe in design.

All stopping mechanisms for the machinery should be inspected regularly to ensure proper operation. The protected machinery must have a consistent reliable and repeatable stopping time.

ATTENTION

Failure to read and follow these instructions can lead to misapplication or misuse of the GuardShield safety light curtains, resulting in injury and damage to equipment.



Table of Contents

GuardShield PAC Safety Light Curtain 3

Introduction..... 3

Safety Precautions 4
 Principles of Safe Use and Symbols Used..... 4

Specialist Personnel 4
 Range of Uses of the Device..... 4
 Proper Use..... 4
 General Protective Notes and Protective Measures..... 4

Product Description..... 5
 Special Features 5
 Light Curtain Principle of Operation 5
 Examples of Range of Use..... 6
 Safety Functions 6

Installation and Mounting..... 11
 Response Time 9

Determining the Safety Distance..... 9
 US Safety Distance Formula 9
 OSHA Safety Distance Calculation Formula 9
 The ANSI Safety Distance Formula 10
 European Safety Distance Formula 10
 Multiple GuardShield PACs 12
 Mounting Brackets..... 12

Electrical Installation..... 13
 Connections..... 13
 Wiring Diagram..... 15
 Checklist 22
 System Status Indicators 21

System Configuration 19
 Teach Function 20
 Troubleshooting Guide 20

Safety Instructions—Maintenance 22
 Daily Inspection..... 22
 Six-month Inspection 23
 Cleaning..... 23
 Technical Specifications 24
 Model Overview 25
 Dimensions..... 26

Accessories 28

Generally recognized technical regulations and quality assurance system ISO 9000 are carefully applied during the development and production of Allen-Bradley/Guardmaster products.

This technical description must be followed when installing and commissioning the GuardShield PAC. Inspection and commissioning must be carried out by a qualified person.

Rockwell Automation reserves the right to make changes or revisions to the material contained in this publication and cannot be held liable for incidental or consequential damages resulting from the furnishing, performance or use of this material.

This manual covers the operation and installation of the:

- Standard GuardShield PAC light curtain
- GuardShield PAC with Integrated Laser Alignment system
- GuardShield PAC with Integrated Laser Alignment and ArmorBlock Guard I/O connectivity

GuardShield PAC Safety Light Curtain

Introduction

The GuardShield PAC safety light curtain is a multiple beam, presence sensing device designed for perimeter or access detection around hazardous machinery or equipment. The GuardShield PAC is a Type 4 AOPD per IEC 61496. It is a self-contained, optically synchronized, two box (transmitter and receiver) safety light curtain with dip switch selectable operating modes.

The GuardShield PAC safety light curtain consists of a non-matched pair of optic units, i.e., transmitter and receiver. The transmitter and receiver operate on +24V DC. The maximum distance between transmitter and receiver is referred to as the protective field width or range. The protective field height is the distance between the first and last beam in the device.

The transmitter emits sequential pulses of infrared light which are received and processed by the GuardShield PAC receiver. The synchronization of the timing of the emission and reception of infrared light pulses is accomplished optically by the first beam adjacent to the GuardShield PAC status LEDs. This beam is referred to as the synchronization beam. Because the GuardShield PAC transmitter and receiver are optically synchronized, no electrical connection is required between the transmitter and receiver.

The GuardShield PAC receiver has two safety outputs, Output Signal Switching Devices (OSSDs) and one nonsafety auxiliary output. When the GuardShield PAC transmitter and receiver are properly powered and aligned, all OSSDs are current sourcing +24V DC with a switching capacity of 500 mA. The two safety OSSDs are cross monitored and short-circuit protected. Interruption of the sensing field causes the receiver to switch the sourced current OFF (0V DC).

Restoring the GuardShield PAC sensing field, (in Guard only configuration) causes all outputs (OSSDs) to switch to the active high state (resume current sourcing +24V DC with a switching capacity of 500 mA).

The GuardShield PAC is offered in a number of configurations based on a standard Type 4 safety light curtain platform.

In addition to the standard GuardShield PAC, the GuardShield PAC is offered with an integrated laser alignment system or with an integrated laser alignment system with connectivity to ArmorBlock Guard I/O. The ArmorBlock Guard I/O option allows network connectivity providing OSSDs over a DeviceNet™ or DeviceNet safety network. The ArmorBlock™ Guard I/O option is only available in GuardShield PACs with integrated laser alignment systems.

Selectable functions of the GuardShield PAC and GuardShield PAC with integrated laser alignment are:

- Beam coding
- EDM (External Device Monitoring)
- Start interlock
- Restart interlock

Selectable functions of GuardShield PAC with ArmorBlock Guard I/O connectivity:

- Beam coding

Range of Uses of the Device

The GuardShield PAC safety light curtain is classified as electro-sensitive protective equipment (ESPE). The maximum protective field width is 16m (52.5ft) for the GuardShield PAC.

The device is a *Type 4 ESPE* as defined by IEC 61496-1 and CLC/TS 61496-2 and is therefore allowed for use with controls in safety category Type 4 in compliance with EN ISO 13849, SIL CL3 in accordance with EN 62061 or up to PLe in accordance with EN ISO 13849. The device is suitable for:

- Hazardous area protection
- Access protection

Access to the hazardous point must be allowed only through the protective field. The machine/system is not allowed to start as long as personnel are within the hazardous area. Refer to the “Examples of Range of Use” on page 6 for an illustration of the protection modes.

The GuardShield PAC is intended as a perimeter or access protection device for a whole body detection and can not be used in horizontal detection applications as it may be possible for personnel to step between the beams and access the hazard without being detected.

Depending on the application, mechanical protection devices may be required in addition to the safety light curtain.

IMPORTANT

These installation instructions are designed to address the technical personnel of the machine manufacturer and or the installer of the safety system regarding the proper mounting, configuration, electrical installation, commissioning, operation and maintenance of the GuardShield safety light curtain.

These installation instructions do not provide instruction for the operation of machinery to which the GuardShield safety light curtain is, or will be, integrated. Only qualified personnel should install this equipment.

IMPORTANT

Additional measures may be necessary to ensure that the ESPE does not fail to danger when other forms of light radiation are present in a particular application (i.e., use of cableless control devices on cranes, radiation from weld spatter or effects from strobe lights).

GuardShield PAC Laser Alignment

The laser light source in the integrated laser alignment system of the GuardShield PAC light curtains is a Class 1, eye safe laser diode with a wavelength of 670 nm.

This Class 1, eye safe laser is switched from a low output power state to a high output power state (and back again) by means of control circuitry which detects reflected laser light from a temporary blockage of the emitted laser light. This is most commonly accomplished by a person's finger placed over the laser overlay window. There is also an automatic shutdown feature that switches the laser diode from the high power state to the low power state, if there is no finger or other interruption detected for a period of five minutes.

During the high output mode of operation, the laser is pulsed at a rate of approximately 2 Hz in order to facilitate finger detection in high ambient light conditions.

ATTENTION

Use of controls or adjustments or performance of procedures other than those specified herein, may result in hazardous radiation exposure.

Safety Precautions

Principles for Safe Use and Symbols Used

The following instructions are preventive warnings to ensure the safe and proper operation of the GuardShield PAC. These instructions are an essential part of the safety precautions and therefore have to be observed at any time.

Throughout this manual we use the labels **ATTENTION** and **IMPORTANT** to alert you to the following:

ATTENTION

Failure to observe may result in dangerous operation

ATTENTION: Identifies information about practices of circumstances that can lead to personal injury or death, property damage, or economic loss.

ATTENTION helps you

- Identify a hazard
- Avoid a hazard
- Recognize the consequences

IMPORTANT: Identifies information that is especially important for successful application and understanding of the product.

ATTENTION

Potentially hazardous situation, which, if not prevented, might lead to serious or deadly injury.

Failure to observe may result in dangerous operation.

ATTENTION

The GuardShield PAC must not be used with machines that cannot be stopped electrically in an emergency.

The safety distance between the GuardShield and a dangerous machine movement has to be maintained at all times.

Additional mechanical protective devices have to be installed in a way that hazardous machine elements cannot be reached without passing through the protective field.

The GuardShield has to be installed in a way that operators can only operate within the sensing area.

Improper installation can result in serious injury.

Never connect the outputs to +24V DC. If the outputs are connected to +24V DC, they are in ON-state and cannot stop hazardous spots at the machine/application.

Never expose the GuardShield to flammable or explosive gases.

Regular safety inspections are imperative (see maintenance).

Do not repair or modify the GuardShield. The GuardShield safety light curtain is not field repairable and can only be repaired at the factory. Removal of either of the GuardShield endcaps will void the warranty terms of this product.

Specialist Personnel

The GuardShield PAC safety light curtain must be installed, commissioned and serviced only by a qualified person. A qualified person is defined as a person who:

- Has undergone the appropriate technical training

and

- Who has been instructed by the responsible machine operator in the operation of the machine and the currently valid safety guidelines

and

- Who has read and has ongoing access to these installation instructions

Proper Use

The GuardShield PAC safety light curtain must be used only as defined in the "Range of Uses of the Device." It must be used only by qualified personnel and only on the machine where it has been installed and initialized by qualified personnel.

If the device is used for any other purposes or modified in any way, warranty claims against Allen-Bradley Guardmaster shall become null and void.

General Protective Notes and Protective Measures

IMPORTANT

Safety Notes

Please observe the following items in order to ensure the proper and safe use of the GuardShield safety light curtain.

- The national/international rules and regulations apply to the installation, use and periodic technical inspections of the safety light curtain, in particular:
 - ◆ Machine Directive 98/37/EEC
 - ◆ Equipment Usage Directive 89/655/EEC
 - ◆ The work safety regulations/safety rules
 - ◆ Other relevant health and safety regulations

Manufacturers and users of the machine with which the safety light curtain is used are responsible for obtaining and observing all applicable safety regulations and rules.

- The notices, in particular the test regulations of these installation instructions (e.g. on use, mounting, installation or integration into the existing machine controller) must be observed.
- The tests must be carried out by specialist personnel or specially qualified and authorized personnel and must be recorded and documented to ensure that the tests can be reconstructed and retraced at any time.
- The installation instructions must be made available to the user of the machine where the GuardShield PAC safety light curtain is installed. The machine operator is to be instructed in the use of the device by specialist personnel and must be instructed to read the installation instructions.

Product Description

This section provides information on the special features and properties of the safety light curtain. It describes the structure and functions of the unit, in particular the different operating modes.

- Please read this section before mounting, installing and commissioning the unit.

Special Features

- Start interlock
- Restart interlock
- External Device Monitoring (EDM)
- Machine test signal
- Beam coding

GuardShield Light Curtain Principle of Operation

The GuardShield PAC safety light curtain consists of a nonmatched pair of optic units, i.e. transmitter and receiver with the same number of beams and spacings. The transmitter and receiver operate on +24V DC. The maximum distance between the transmitter and receiver is referred to as the protective field width or range. The protective field height is the distance between the first beam and the last beam in the device.

The transmitter emits sequential pulses of infrared light, which are received and processed by the GuardShield PAC receiver. The synchronization of the timing of the emission and reception of infrared light pulses is accomplished optically by the first beam adjacent to the GuardShield PAC's status LEDs. This beam is

referred to as the synchronization beam. Because the GuardShield PAC's transmitter and receiver are optically synchronized, no electrical connection is required between the transmitter and receiver.

The GuardShield PAC's receiver has two safety outputs, OSSDs (Output Signal Switching Devices) and one nonsafety auxiliary output. When the GuardShield PAC's transmitter and receiver are properly powered and aligned, all OSSDs are current sourcing +24V DC with a switching capacity of 500mA. The two safety OSSDs are cross monitored and short-circuit protected. Interruption of the sensing field causes the Receiver to switch the sourced current Off (0V DC).

Restoring the GuardShield PAC's sensing field, (in Guard only configuration) causes all outputs (OSSDs) to switch to the active high state (resume current sourcing +24V DC with a switching capacity of 500mA).

The GuardShield PAC Light Curtain

The GuardShield PAC safety light curtain consists of a transmitter and a receiver.



Figure 1: Components of the GuardShield PAC

The individual beams of the GuardShield PAC are identified by markings on the housings.

The *width of the protective field* is derived from the length of the light path between sender and receiver and must not exceed the maximum rated width of the protective field 16 m (52.5 ft).

The GuardShield PAC is also offered with an integrated laser alignment system which has a constantly powered Class 1, eye safe laser located in the top of the GuardShield PAC transmitter and in the bottom of the GuardShield PAC receiver. Each Class 1, eye safe laser emits a low level of visible light. Simply blocking this light below the finger symbol causes the light to be reflected back to a photo sensor which changes the condition of the laser light. If this light is at a low level, interrupting it will cause the laser to emit a highly visible level of light. Interrupting the visible light in the same location will cause the laser to switch to a low level of emission. The emission of visible light will also change to a low level after five minutes of activation.

Across from each laser is a target used to help with the alignment of the GuardShield PAC pair. Positioning the visible light in the center of the top and bottom targets will position the GuardShield PAC pair for optimal alignment.

Examples of Range of Use

The GuardShield PAC safety light curtain operates as a proper protective device only if the following conditions are met:

- The control of the machine must be electrical.
- The controlled machine must be able to be stopped anywhere in the machine's stroke or cycle.
- The transmitter and receiver must be mounted such that access to the hazard is only through the light curtain's protective field.
- The restart button must be located outside the hazardous area such that it cannot be operated by a person working inside the hazardous area.
- The statutory and local rules and regulations must be observed when installing and using the device.

Safety Functions

The GuardShield PAC safety light curtain offers a variety of functions, which are integral to the system.

Operating modes, functions and features of the GuardShield PAC system are activated through dip switch settings.

IMPORTANT

The protective system must be tested for proper operation after each and every change to the configuration.

Guard Only

When in the guard only mode of operation, the light curtain operates as an on/off device, meaning the OSSD outputs switch off/on according to an obstruction or clearing of the detection field. The GuardShield PAC is shipped from the factory in the guard only mode.

Start Interlock

The start interlock prevents the OSSD outputs from switching to ON state after power up of the system with the protective field unobstructed. A manual reset of the system is required for the GuardShield PAC to enter the ON state.

This can be accomplished by one of two methods.

- Actuation of a momentary N.O. push button
- Interruption and restoration of the protective field within one second.

Activation of this mode of operation and selection of the resetting method is through dip-switch settings. Indication of this mode of operation is through illumination of a yellow LED on the GuardShield PAC's receiver.

IMPORTANT

Start interlock is not available in GuardShield PAC light curtains with ArmorBlock Guard I/O connectivity.

Restart Interlock

The restart interlock mode of operation prevents the OSSD outputs from switching to ON after interruption and clearance of the protective field. A manual reset of the GuardShield PAC

system is required. Resetting of the system is accomplished through a momentary N.O. push button or key switch. Configuration and activation of this mode of operation is through dip-switch settings. The Restart Interlock mode is indicated by the illumination of a yellow LED on the GuardShield PAC's receiver.

IMPORTANT

It is not possible to have both "Start Interlock" and "Restart Interlock" configured at the same time in the GuardShield PAC. Configuring "Restart Interlock" behaves the same as "Start Interlock" at power up, i.e., a reset of the system is required at power up.

Restart interlock should always be configured for the GuardShield PAC light curtains. The reset switch should be located outside of the work cell and positioned so that a clear view of the work cell is possible.

Restart interlock is not available in GuardShield PAC light curtains with ArmorBlock Guard I/O connectivity; this functionality must be configured and through the safety PLC.

External Device Monitoring (EDM) or Machine Primary Control Element (MPCE) Monitoring

The External Device monitoring function (EDM) is an input signal to the GuardShield receiver from the Final Switching Device (FSD), usually relay contactors, which control the hazardous motion of equipment or machinery. The EDM circuit is required to see a change of state of the FSD within 300ms of the restoration of the GuardShield's sensing field after its interruption. Detection of an unsafe condition such as a welded contact causes the GuardShield receiver to go to a lockout condition (OSSDs OFF).

The activation and use of this GuardShield functionality usually allows the GuardShield's OSSDs to be connected directly to a machine's FSD and attain a Category 4 safety circuit. It is necessary to have the EDM circuit connected to two separate FSDs which are wired in series to attain the Category 4 rating. Activation of this functionality is accomplished by setting the EDM dipswitch no. three to the OFF position and then performing the "Teach" function. It is also necessary to connect the GuardShield receiver's EDM (yellow) wire to a N.C. output from the FSD.

IMPORTANT

EDM is not available in GuardShield PAC light curtains with ArmorBlock Guard I/O connectivity.

System Testing

The GuardShield PAC performs a complete system self-test at power up and switches to the ON state if the system is properly aligned and the protective field is unobstructed and the start/restart interlock modes of operation are deactivated.

External Test (Machine Test Signal)

A test cycle of the system can be triggered by an external test signal to the GuardShield PAC's transmitter. Supplying or removing a signal (+24V DC) via a N.C. or N.O. switch at the test input deactivates the transmitter for the duration of the test signal, simulating an interruption of the protective sensing field.

The test input must be configured via a dip-switch located in the GuardShield PAC transmitter.

Beam Coding

If several safety light curtains are operating in close proximity to one another, it is possible that the transmitter's infrared light from one GuardShield PAC system is "seen" by another GuardShield PAC system's receiver. To prevent this optical interference, the GuardShield PAC has the ability to have the transmitter generate different beam patterns, which is referred to as "Beam coding." Selection and activation of beam coding is accomplished through dip-switch settings in both the transmitter and receiver.

The following settings are available in the GuardShield PAC safety light curtain; noncoded and coded.

IMPORTANT Beam coding improves resistance to optical interference.

Beam coding increases the system's response time, which may also increase the required safety distance. Refer to Safety Distance calculations on page 9 of this manual.

Applications and Application Requirements

Applications

The GuardShield PAC multi-beam safety light curtain may be used as an opto-electronic fence; detecting the presence of personnel as they pass through the sensing field or for safeguarding access to a hazardous area or machine process. Used in combination with corner mirrors, the GuardShield PAC multi-beam safety light curtains provide multiple-side access detection.

When using corner mirrors to protect multiple sides of a machine or work cell, the GuardShield PAC with integrated laser alignment is the preferred solution. Activation of visible laser light allows positioning and adjustment of the transmitter, receiver and corner mirrors.

A typical system configuration for access detection to a hazardous area or machine process is to have the GuardShield PAC multi-beam safety light curtain connected to an external module along with two or four sensors. The external module allows material to pass through the GuardShield PAC multi-beam's sensing field without stopping the machine or equipment as long as the muting conditions are met. As the material is moving through the process, the GuardShield PAC multi-beam's sensing field is interrupted and the outputs switch to the OFF state. However, if the muting module sensors are interrupted with the proper timing, the module disregards the GuardShield PAC multi-beam's outputs and remains in the ON condition, allowing the machinery or equipment to continue operation.

If the muting sensors are not interrupted and maintained in the required timing and or sequence, the muting module will switch OFF when the GuardShield PAC multi-beam's sensing field is interrupted.

Figure 2 is an example of a GuardShield PAC three-beam safety light curtain used as an opto-electronic fence with corner mirror columns.

Figure 3 is an example of a GuardShield PAC three beam with four retroreflective sensors and an external muting module.

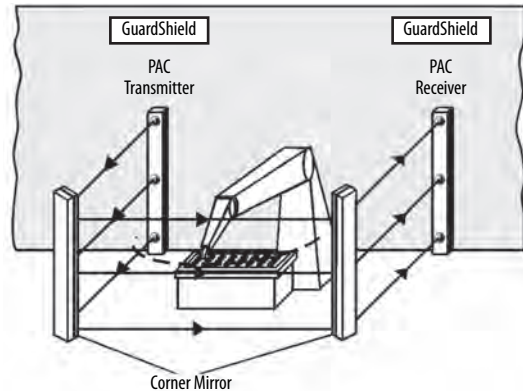

Figure 2: GuardShield PAC three beam with corner mirror columns

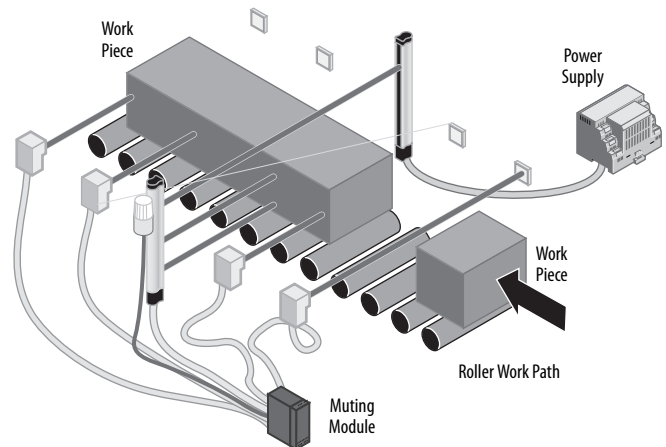

Figure 3: GuardShield PAC three beam with muting module

Application Requirements

The protective functions of the PAC can only be used properly when the following conditions are satisfied:

- The machine or installation must be controlled electrically.
- It must be possible to stop hazardous machine movement.
- The PAC must be installed so that entry into the danger zone interrupts one or more of the light beams.

The light beam diameter of 23 mm (0.90 in.) must be fully covered, to assure a change in state of outputs.

Release can only be achieved with the use of a restart switch.

The restart switch must be located such that it cannot be pressed from inside the danger zone.

The GuardShield PAC should be mounted such that upon interruption of the light beam, the dangerous location can only be reached if the dangerous condition of the machine has been stopped. The requirement for this is that there is a proper safety

GuardShield™ PAC Safety Light Curtain Installation Instructions

distance between the light beams and the nearest point of danger.

Persons situated inside the danger zone, but outside the protection field are not recognized. It must therefore be ensured that a dangerous condition is only possible when there is nobody present in the danger zone.

The relevant legal and government regulations are to be complied with the implementation of protection installations. These regulations vary, depending on areas of application.

Corner Mirrors and Mounting Columns

The GuardShield two- and three-beam PACs can be used with one or two corner mirrors to provide two- or three-sided protection. The use of each corner mirror reduces the maximum range of the GuardShield PAC by at least 10% per mirror.

It is possible to use full length corner mirrors (440L-AM075 series, 440L-AM125 series).

Rockwell also offers pedestal floor mounting stands (440L-AMSTD) which will accommodate the mounting of the GuardShield two- or three-beam PAC with the appropriate full length corner or mirror column mirrors.

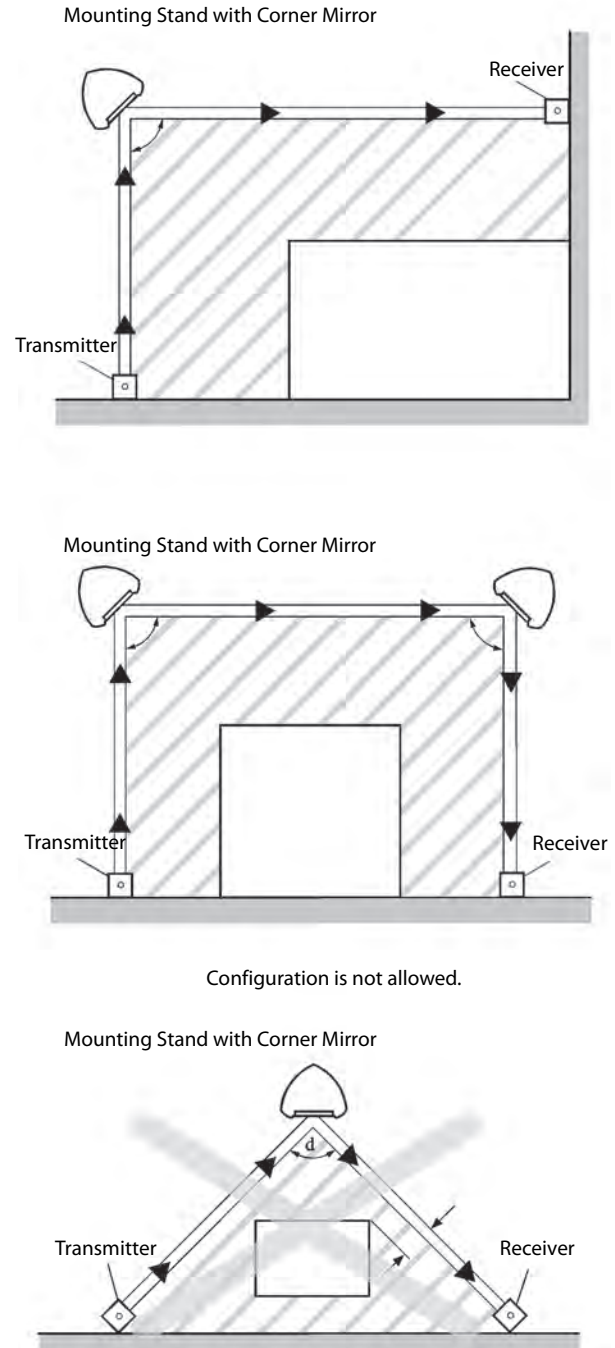

Figure 4: Multi-sided access control to danger zones with PAC multi-beam safety light barrier

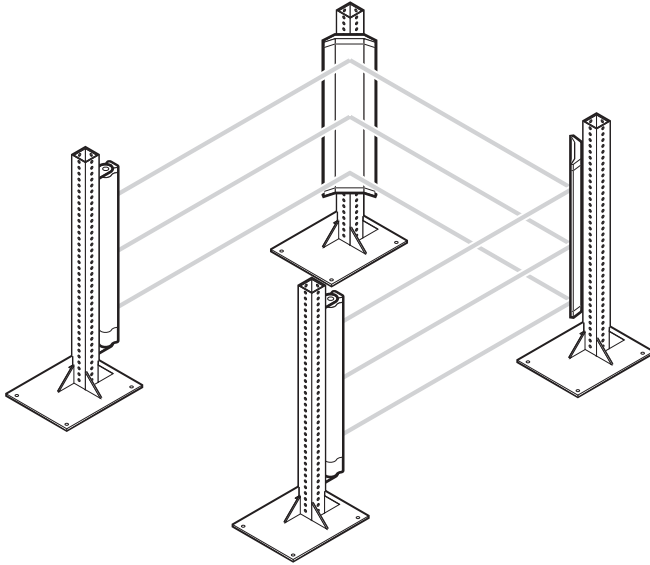

Figure 5: GuardShield three-beam PAC and corner mirrors mounted to pedestal floor stands

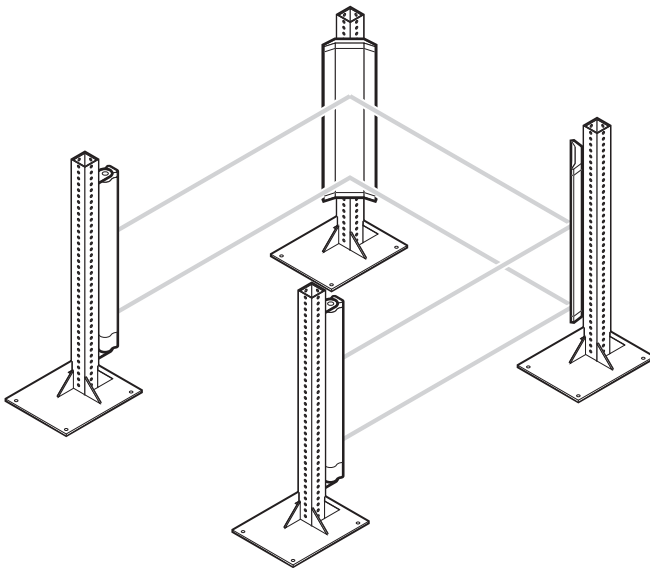

Figure 6: GuardShield two-beam PAC and corner mirrors mounted to pedestal floor stands

Figures 5 and 6 show two- and three-beam GuardShield PACs with two corner mirrors providing three-sided detection. Mirrors are offered in either narrow or wide styles in heights to accommodate two- or three-beam GuardShield PACs.

Response Time

The response time of the two- and three-beam GuardShield PAC safety light curtain is 20 ms without beam coding or 30 ms with beam coding.

IMPORTANT

Determining Stop Time: The measurement of stopping time (T_s) must include the stopping times of all devices in the stop circuit. Not including all device and control system elements when calculating T_s will result in an inaccurate safety distance calculation.

Determining the Safety Distance

The light curtain must be mounted with proper safety distance

- From the point of danger
- From reflecting surfaces

US Safety Distance Formula

ATTENTION



The GuardShield PAC safety light curtains must be mounted at a sufficient distance from the hazardous motion to ensure that the machine stops before a person's body reaches the hazard.

This distance, referred to as the safety distance, must be properly calculated prior to mounting the light curtains around the machinery. Failure to properly calculate this safety distance may result in operator injury.

In the United States there are two formulas that are used to properly calculate the safety distance. The first, the OSHA formula, is the minimum requirement for the calculation of the safety distance. The second formula, the one recommended by Rockwell Automation, is the ANSI formula, which incorporates additional factors to be considered when calculating the safety distance.

OSHA Safety Distance Calculation Formula

The OSHA safety distance formula as specified in CFR Subpart O 1910.217 is as follows:

$$D_s = 63 \times T_s$$

D_s	Safety Distance
63	Is the OSHA recommended hand speed constant in inches per second
T_s	Is the total stop time of all devices in the safety circuit, measured in seconds. This value must include all components involved in stopping the hazardous motion of the machinery. For a mechanical power press it is the stopping time measured at approximately the 90° position of the crankshaft rotation.

IMPORTANT

The T_s number must include the response times of *all* devices, including the response time of the safety light curtain, the safety light curtain controller (if used), the machine's control circuit and any other devices that react to stop the hazardous motion of the machinery. Not including the response time of a device or devices in the stop time calculation will result in insufficient safety distance for the application. This may result in operator injury.

$$D_s = 63 \text{ in./sec} \times (0.250 + 0.050 + 0.02) + 48 \text{ in.}$$

$$D_s = 20.16 \text{ in.} + 48 \text{ in.}$$

$$D_s = 68.16 \text{ in. from hazardous motion}$$

The GuardShield three beam PAC should be mounted at least 68.2 in. from the closest reachable hazard point of the protected machinery or equipment.

European Safety Distance Formula

A safety distance must be maintained between the light curtain and the point of danger. This safety distance ensures that the point of danger can only be reached after the dangerous state of the machine has been completely removed.

The safety distance as defined in EN ISO 13855 and EN ISO 13857 depends on:

- Stopping/run-down time of the machine or system. (The stopping/run-down time is shown in the machine documentation or must be determined by taking a measurement.)
- Response time of the protective device
- The person's speed of approach
- Resolution of the light curtain and/or beam separation

When using the GuardShield PAC three beam with 400 mm beam spacing, EN 999 requires that the first beam should be mounted at 300 mm above the floor. When mounted in this configuration, it is necessary to add 850 mm as the value for "C" in the safety distance calculation equation.

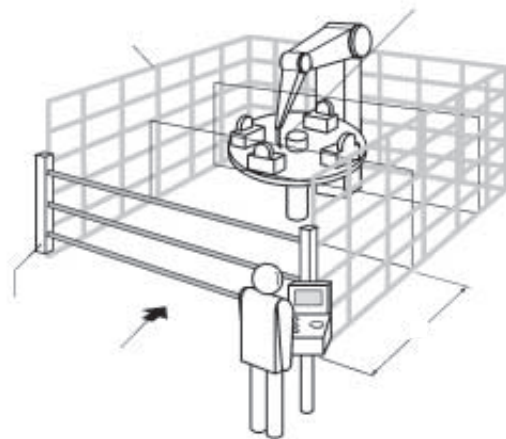

Figure 7: Safety distance from the point of danger

The ANSI Safety Distance Formula

The ANSI safety distance formula, which is the Rockwell Automation recommended formula, is as follows:

$$D_s = K \times (T_s + T_c + T_r + T_{bm}) + D_{pf}$$

- D_s** Minimum safety distance between the safe guarding device and the nearest point of operation hazard, in inches.
- K** Hand speed constant in inches per second. The ANSI standard value is 63 in. per second when the operator begins reaching toward the point of operation hazard from rest. NOTE: ANSI B11.19 1990 E4.2.3.3.5 states "The value of the hand speed constant, K, has been determined by various studies and although these studies indicate speeds of 63 inches/second to over 100 in./second, they are not conclusive determinations. The employer should consider all factors, including the physical ability of the operator, when determining the value of K to be used."
- T_s** Stop time of the machine tool measured at the final control element.
- T_c** Response time of the control system
- Note:** T_s and T_c are usually measured by a stop time measuring device.
- T_r** Response time of the presence sensing device (safety light curtain) and its interface, if any. This value is generally stated by the device manufacturer or it can be measured by the user.
- T_{bm}** Additional time allowed for the brake monitor to compensate for variations in normal stopping time.
- D_{pf}** Depth penetration factor. It is an added distance to allow for how far into the protective field an object, such as a finger or hand, can travel before being detected. D_{pf} is related to the safety light curtain's object sensitivity. Object sensitivity is the smallest diameter object which will always be detected anywhere in the sensing field.

Example—Reach Over

In this example, the value of K is the hand speed constant of 63 in. per second, the T_s machine stop time is 250 ms (0.250 sec), the 20% brake wear factor is 0.05 sec and the GuardShield PAC response time is 20 ms (0.020 sec). The D_{pf} is 48 in. for reach over applications.

How to Calculate the Safety Distance S According to EN ISO 13855 and EN ISO 13857:

- First, calculate S using the following formula:
 $S = 1600 \times (T_s + T_r) + C$

Where ...

T_s = stopping/run-down time of the machine + response time of the protective device [s]

T_r = response time of the GuardShield PAC

S = safety distance [mm]

C = safety supplement

$S = 1600 \times (0.250 + 0.020) + 850 \text{ mm}$

$S = 1600 \times (0.270) + 850 \text{ mm}$

$S = 432 + 850 \text{ mm}$

$S = 1282 \text{ mm}$

Minimum Distance from Reflecting Surfaces

The infrared light from the sender may be reflected off of shiny surfaces and be received by the system’s receiver. If this condition occurs, it can result in an object not being detected when it enters the GuardShield PAC’s sensing field.

All reflecting surfaces and objects (e.g. material bins) must therefore be located at a minimum distance *a* from the protective field of the system. The minimum distance *a* depends on the distance *D* between sender and receiver.

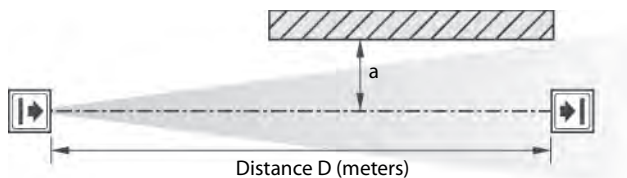

Figure 8: Minimum distance from reflecting surfaces

How to Determine the Minimum Distance from the Reflecting Surfaces:

- Determine the distance *D* [m] sender-receiver
- Read the minimum distance *a* [mm] from the graph:

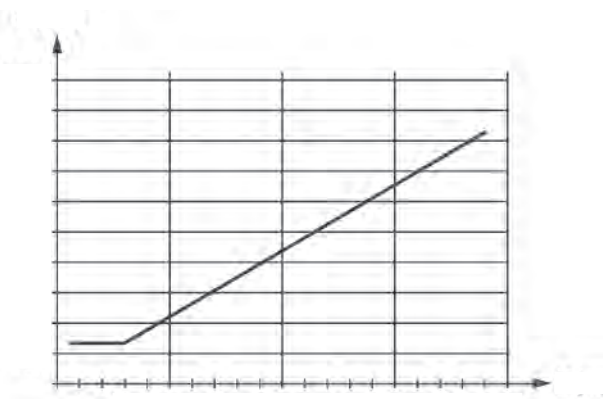

Figure 9: Graph, minimum distance from reflecting surfaces

The effective aperture angle for the GuardShield PAC system is +/- 2.5° at a mounting distance of > 3.0 m (9.8 ft). Calculate the minimum distance to reflecting surfaces depending on the distance between the transmitter and the receiver, using an aperture angle of +/- 2.5°, or take the appropriate value from the following table:

Distance Between Transmitter and Receiver (Range L) [m (ft.)]	Minimum Distance a [mm (in.)]
0.2 to 3.0 (0.65 to 9.8)	135 (5.31)
4.0 (13.1)	175 (6.88)
5.0 (16.4)	220 (8.66)
6.0 (19.6)	265 (10.43)
7.0 (22.9)	310 (12.2)
10.0 (32.8)	440 (17.32)
16.0 (52.4)	700 (27.55)

Note: Note: formula: $a = \tan 2.5^\circ \times D$ [mm]

a = minimum distance to reflecting surfaces
D = distance between transmitter and receiver

Installation and Mounting

This section describes the preparation, selection and installation of the GuardShield PAC safety light curtain.

The GuardShield PAC safety light curtain is suitable for most operating environments (IP65 environmental rating). Proper safety distance must be observed.

IMPORTANT

The installation of the GuardShield PAC safety light curtain must adhere to the ANSI standard B11.19/E4.2.3.3.6, which requires that a presence sensing device shall prevent the operator or others from reasonably reaching over, around, or under the sensing field into the hazardous area. Auxiliary safeguarding may be required in conjunction with the GuardShield PAC to meet this requirement.

Determine if the machinery, on which the GuardShield PAC is to be mounted, meets the requirements as specified in the beginning of this manual, i.e., machinery must be able to be stopped anywhere in its stroke or cycle, consistently and repeatedly.

The GuardShield PAC must be mounted at the proper distance from the point of operation hazard. This distance is referred to as the Safety Distance.

ANSI/RIA 15.06 requires that the first beam of the GuardShield PAC be mounted at 300 mm (12 in.) off of the floor in vertical applications. The protective height of the GuardShield PAC three beam is 820 mm. The combination of 300 mm (12 in.) and 820 mm equals 1120 mm which meets the ANSI/RIA 15.06 requirements of a “reach over” application. This requires that the depth penetration factor (Dpf) be 48 in. when performing the safety distance calculation.

GuardShield™ PAC Safety Light Curtain Installation Instructions

The standard GuardShield PAC has an LED in the receiver which is used as an alignment aid. This LED will begin flashing when the infrared light from the transmitter is “seen” by the receiver. This LED turns off when optimal alignment is attained. An external laser (440L-ALAT) and mounting bracket (440L-AF6109) is offered as an accessory for aligning the GuardShield PAC.

Alignment Procedure: Standard GuardShield PAC

Mount and connect both transmitter and receiver. They must be parallel to each other and be positioned at the same height.

Turn on power to GuardShield PAC system.

Rotate the Transmitter while watching the amber LED on the receiver to find the point where the indicator for the ON state (Green LED) illuminates and the amber LED goes off.

Determine the maximum left and right turning angles and position unit in center. Tighten all hardware assuring that the alignment indicator is not illuminated.

Cycle power to assure that the system powers up and goes to the ON state (alignment indicator is OFF)

The GuardShield PAC meets the requirements of IEC 61496 which requires that the optics of the transmitter and receiver emit and receive infrared light at a maximum of $\pm 2.5^\circ$. This requirement creates a tight optical path of infrared light and as such may make the GuardShield PAC somewhat difficult to align at maximum range or when corner mirrors are being used in the application to provide two or three sided perimeter guarding.

When using the GuardShield PAC in perimeter guarding applications, particularly with corner mirrors, it is best to use the Allen Bradley GuardMaster laser alignment tool to ease the alignment process. The laser alignment tool part number is **440L-ALAT**. It is also necessary to use the GuardShield mounting bracket (**440L-AF6109**) to mount the laser alignment tool to the GuardShield PAC housing

The GuardShield PAC is also offered with an integrated laser alignment system. Select the appropriate cat. nos. for this model of GuardShield PAC.

Alignment Procedure for GuardShield PAC with Integrated Laser Alignment

1. Properly locate the GuardShield PAC pair from the point of operation hazard after performing the safety distance calculation.
2. Using the GuardShield PAC mounting brackets, mount the transmitter and receiver so that they are facing one another and are positioned in the same direction. A reference would be that the indicator LEDs are opposite one another.
3. Turn on each laser by placing a finger or hand in front of each laser.
4. Adjust the transmitter and receiver in such a way that both visible laser beams hit the laser targets opposite each laser. A small deviation from the center of the target is allowable.

Multiple GuardShield PACs

When two or more GuardShield PACs are mounted in close proximity to one another, it may be possible for the receiver of one GuardShield PAC pair to receive infrared light from the transmitter of another GuardShield PAC pair. This optical interference can be over come by the GuardShield PAC feature of Beam Coding. Beam coding changes the pulse pattern of infrared light emitted by a GuardShield PAC transmitter.

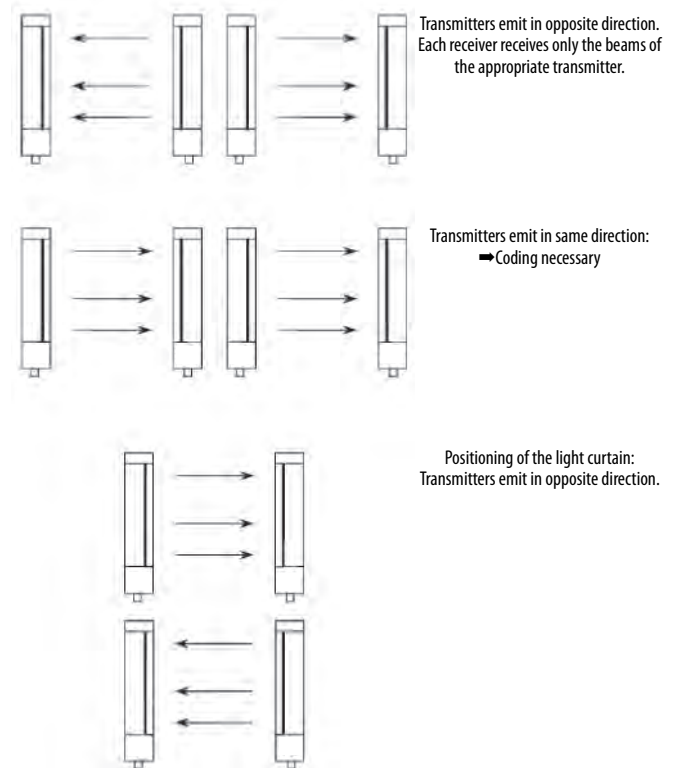

Figure 5: Multiple GuardShield PAC alignment options

Mounting Brackets

The GuardShield PAC is mounted using right angle brackets attached to the endcaps of both transmitter and receiver. Each GuardShield PAC is supplied with standard right angle mounting brackets and self-threading screws. It may be necessary to use additional brackets to mount the GuardShield PAC at a proper safety distance from the machinery hazard.

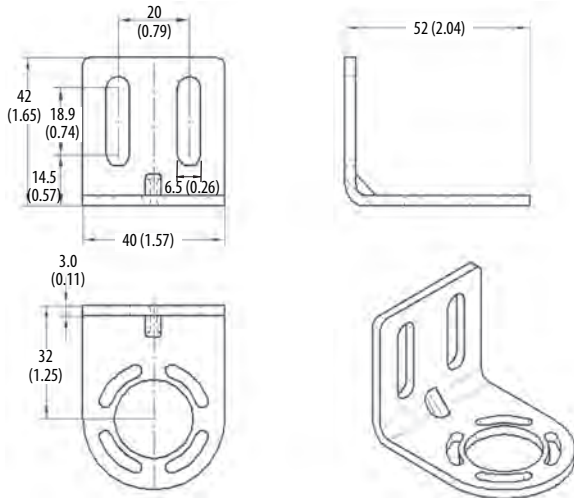

Figure 6: Mounting brackets

Shock Isolation Kits

Rockwell Automation offers a shock and vibration isolation kit (440L-AF6120) for attenuating excessive shock and vibration in vertical applications of the GuardShield PAC safety light curtain. This kit is most effective in extending the operational life of the GuardShield PAC safety light curtains in excessive shock and vibration applications, particularly in applications where shock levels can exceed 50 g.

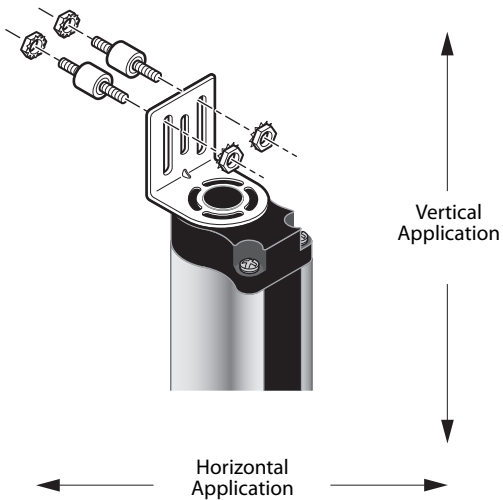

Figure 7: Shock isolation kit

Rockwell Automation also offers pedestal floor stands for mounting the GuardShield light curtains when the shock and vibration levels of the equipment are excessively high. These mounting stands isolate the GuardShield light curtains from receiving the shock through the equipment, however, the area immediately around the machine may also experience high levels of shock and vibration therefore, it may be necessary to use the shock mount kits when mounting the light curtains to the mounting stands.

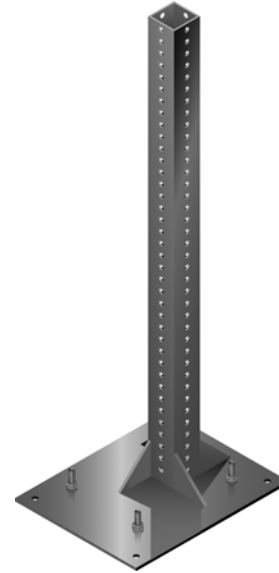

Figure 8: Pedestal floor stand

Electrical Installation

Connections

Power Supply

The external voltage supply (+24V DC) must meet the requirements of IEC 61496-1. In addition, the following requirements have to be fulfilled:

- A short-term power failure of 20 ms must be bridged by the power supply.
- The power supply has double insulation between the primary and the secondary side.
- The power supply is protected against overload.
- The power supply corresponds to the guidelines of the EWG (industrial environment).
- The power supply corresponds to the Low Voltage Directives.
- The grounded conductor of the power supply device must be connected to a grounded conductor PE.
- The maximum deviation of the voltage levels is 24V DC +/- 20%.

GuardShield™ PAC Safety Light Curtain Installation Instructions

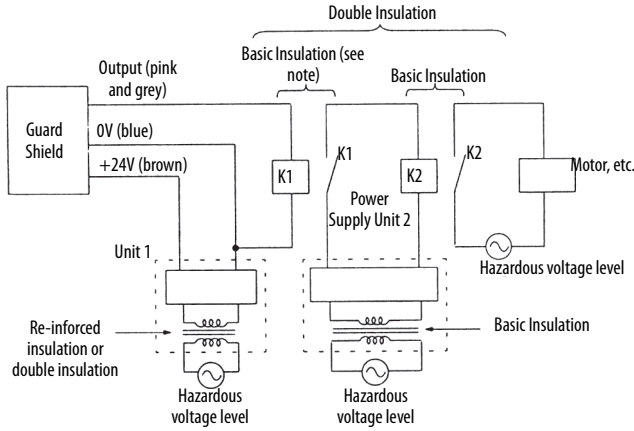

Connections [mm (in.)]

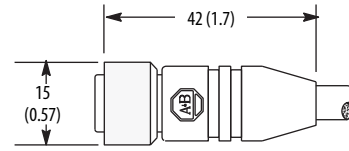

Cables/Connectors

The GuardShield PAC transmitter connector is a four-pin DC micro connector offered in cable lengths from 2 to 30 meters. The GuardShield PAC receiver connector is an 8-pin DC micro connector offered in cable lengths of 2 to 30 meters.

GuardShield PAC Standard and GuardShield PAC with ArmorBlock Guard I/O Connectivity

EDM Connection

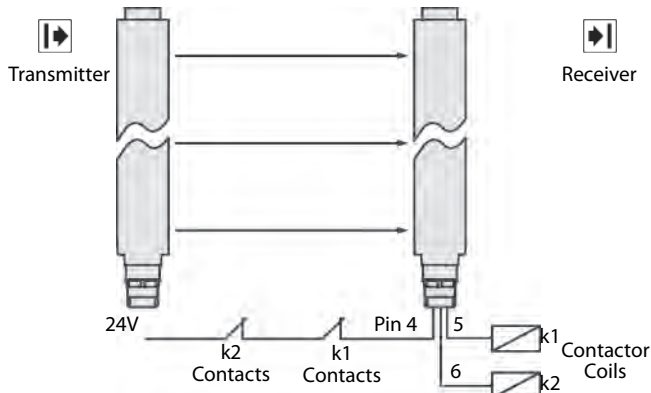

Figure 9: Connecting the contact elements to the EDM

Transmitter Connection Face View of Female DC Micro	Color	Pin No.	Signal
			Transmitter
	Brown	1	+24V DC
	White	2	No Connection
	Blue	3	0V DC
	Black	4	Machine Test Signal

Note: The transmitter is not expected to be connected to the ArmorBlock Guard I/O module.

Standard GuardShield PAC Receiver Connector

Receiver Connection Face View of Female DC Micro	Color	Pin No.	Signal
			Receiver
	White	1	Auxiliary Output
	Brown	2	+24V DC
	Green	3	Ground
	Yellow	4	EDM
	Grey	5	OSSD 1
	Pink	6	OSSD 2
	Blue	7	0V DC
	Red	8	Start/Restart

GuardShield PAC Receiver Connector for ArmorBlock Guard I/O Connectivity

Top View	Color	Pin No.	Signal
			Receiver
	Brown	1	+24V
	White	2	OSSD 2
	Blue	3	0V
	Black	4	OSSD 1
	Grey	5	NC

IMPORTANT Not available for GuardShield PAC with ArmorBlock Guard I/O connectivity.

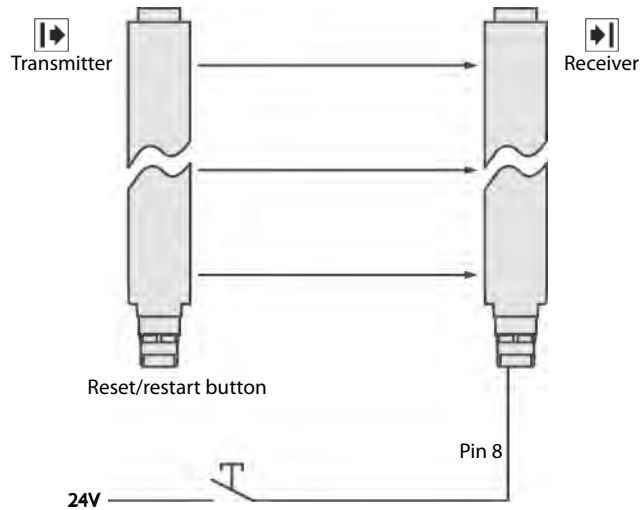

Figure 10: Connecting the reset button/restart button

IMPORTANT Not available for GuardShield PAC with ArmorBlock Guard I/O connectivity.

GuardShield PAC Receiver Interconnecting Patchcords to ArmorBlock I/O

Cat. No.	Description
889D-F5ACDM-0M3	5-pin M12 patchcord, 12 inches
889D-F5ACDM-1	5-pin M12 patchcord, 1 meter
889D-F5ACDM-2	5-pin M12 patchcord, 2 meters
889D-F5ACDM-5	6-pin M12 patchcord, 5 meters
889D-F5ACDM-10	7-pin M12 patchcord, 10 meters

Typical Wiring Diagram—Direct to Contactors

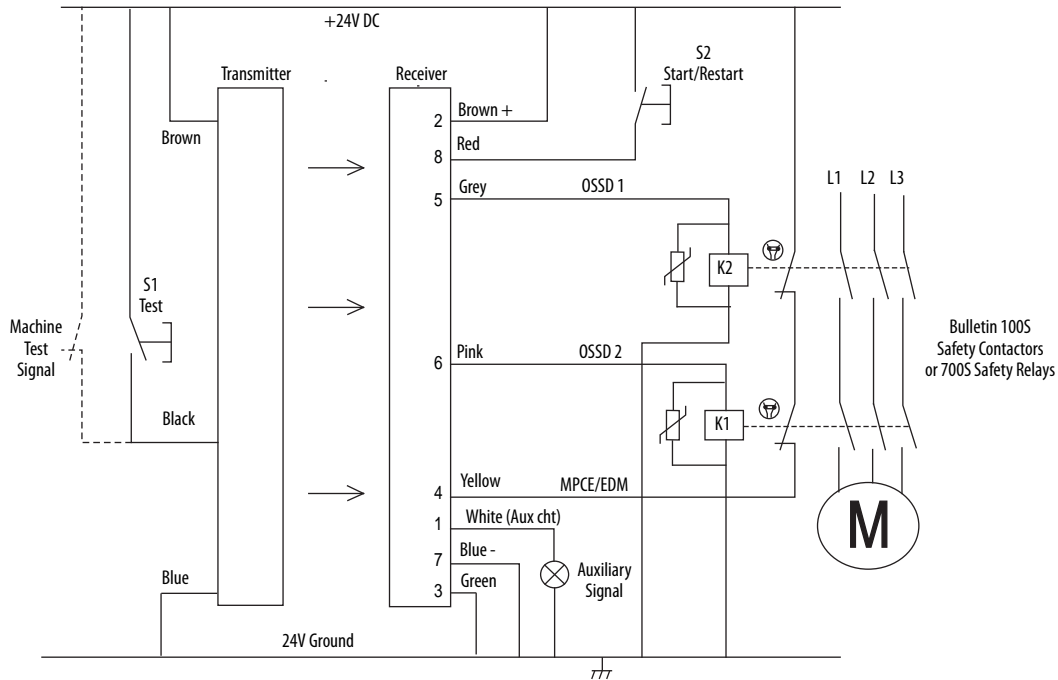

❶ Nonsafety auxiliary output can be connected to a lamp, motor or status to a PLC.

Note: If MPCE/EDM is activated in the GuardShield PAC, the application requires a safety contactor. If MPCE/EDM is not used K1 & K2 can be standard contactors.

Typical Wiring Diagram—To MSR127 Safety Relay Module

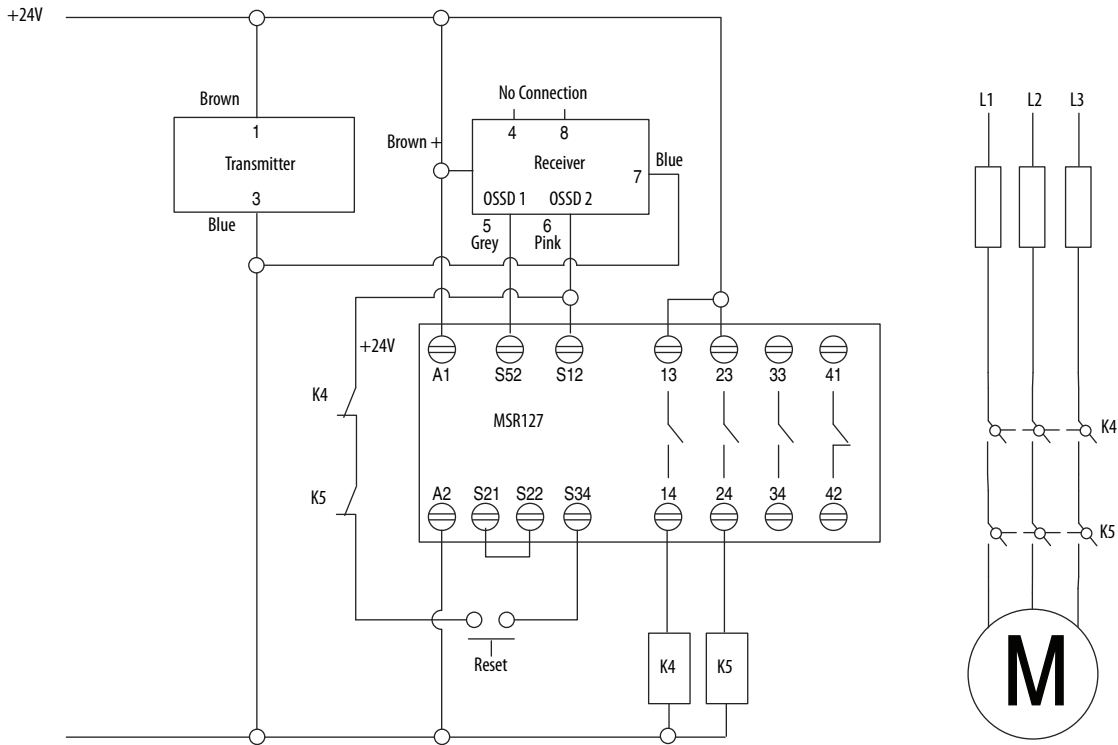

GuardShield Light Curtain Connected to MSR22LM with Two Sensor Muting

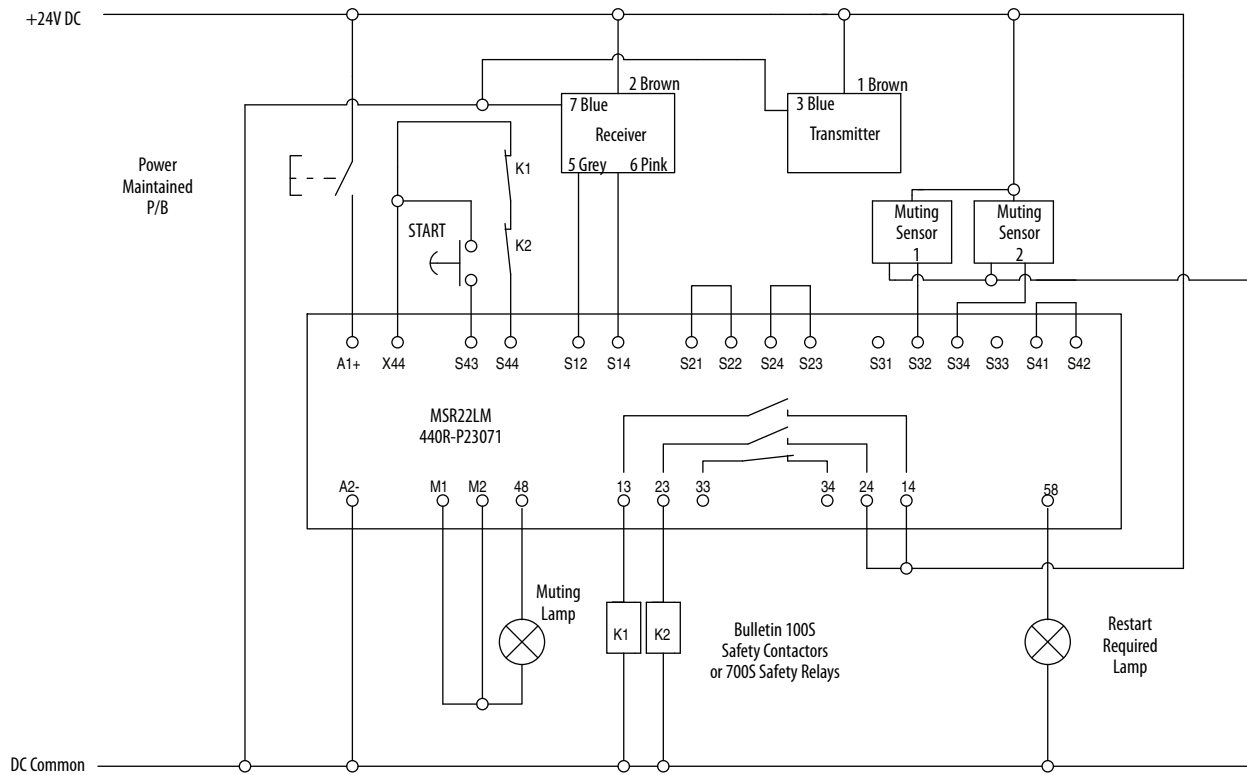

GuardShield Light Curtain Connected to MSR22LM with Four Sensor Muting

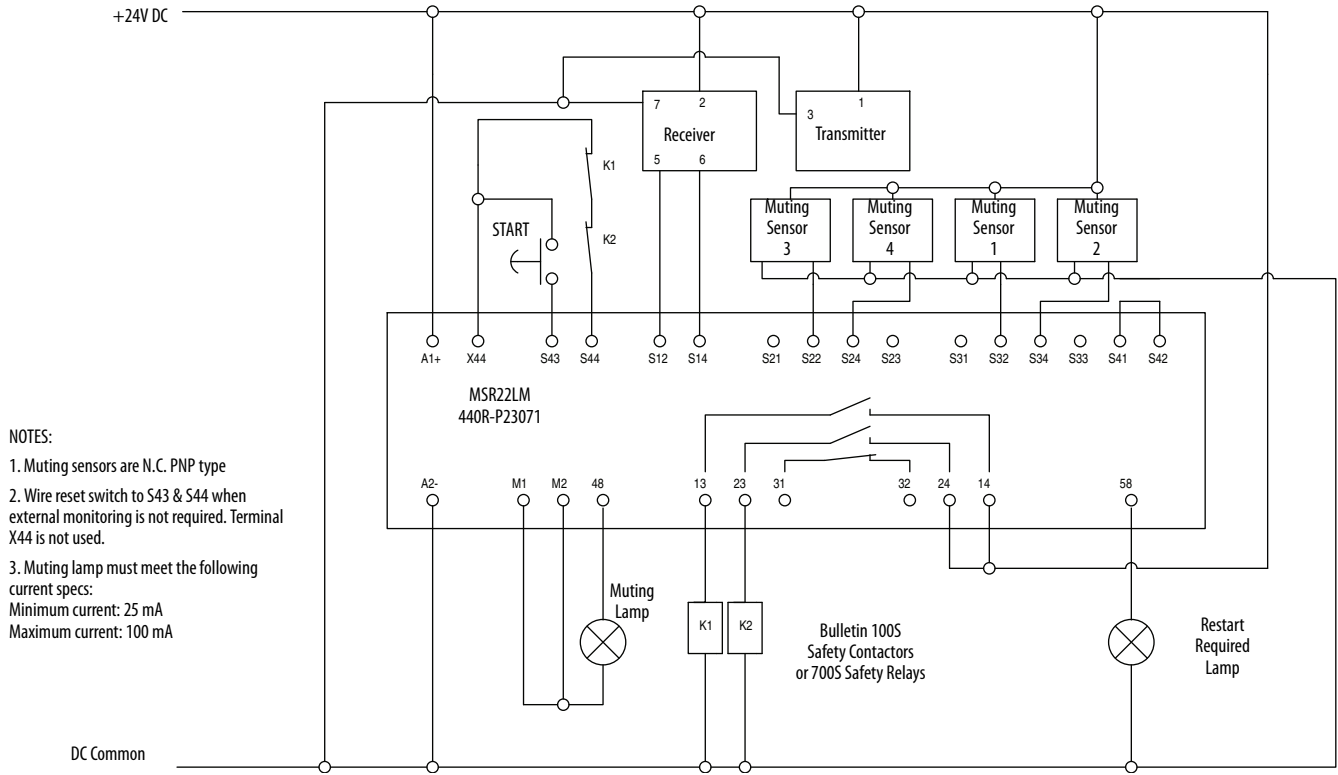

NOTES:

- 1. Muting sensors are N.C. PNP type
- 2. Wire reset switch to S43 & S44 when external monitoring is not required. Terminal X44 is not used.
- 3. Muting lamp must meet the following current specs:
Minimum current: 25 mA
Maximum current: 100 mA

GuardShield Light Curtain Connected to MSR42/MSR45E with Two Sensor Muting

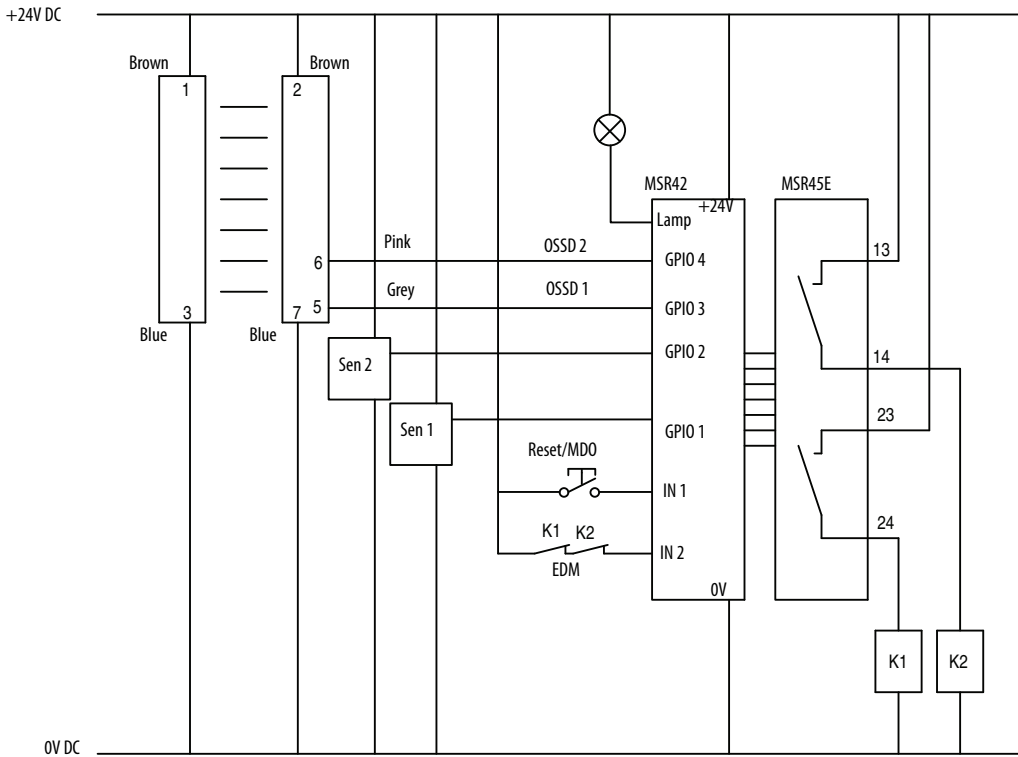

Note: It is necessary to use the optical interface (445L-AF6150) to program the MSR42.

GuardShield Light Curtain Connected to MSR42 with Two Sensor Muting

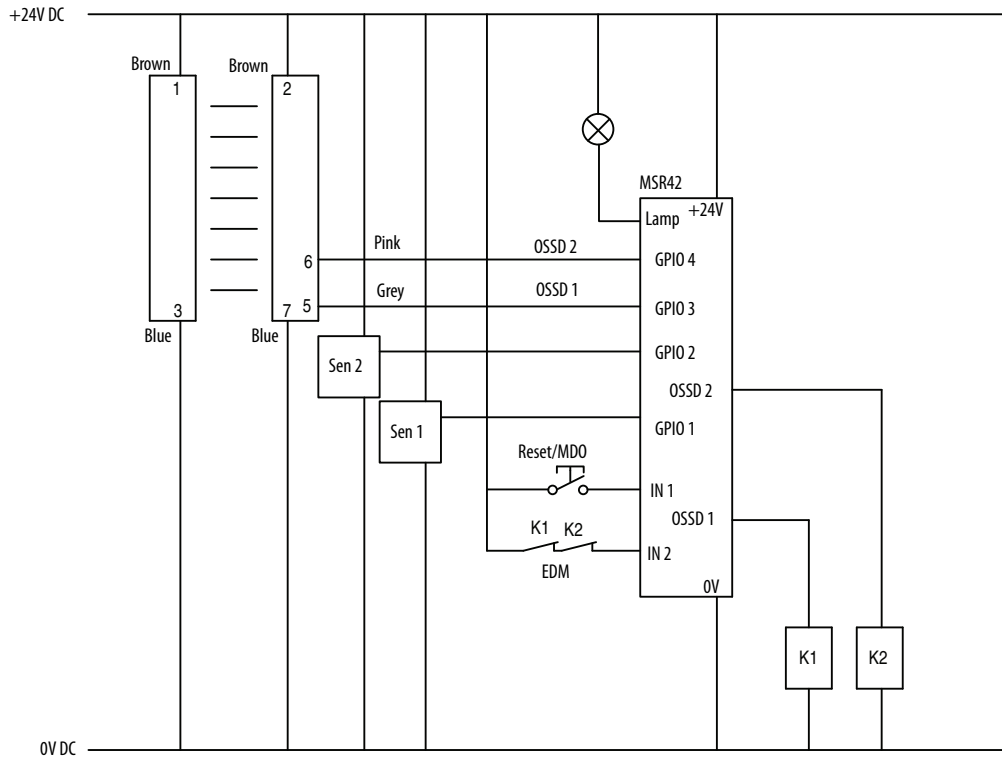

Note: It is necessary to use the optical interface (445L-AF6150) to program the MSR42.

System Configuration

DIP-Switch Selection Settings—Transmitter

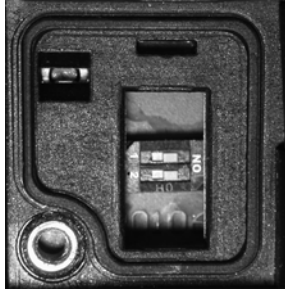

DIP-Switch Selection Settings—Receiver

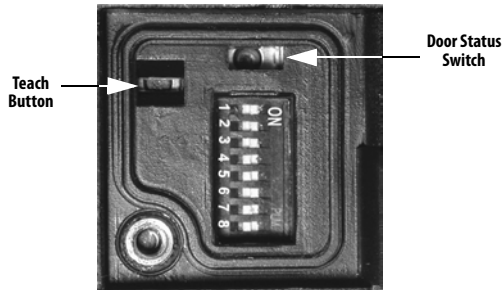

After mounting, electrically connecting and aligning the GuardShield PAC safety light curtain, it is now possible to configure your system.

To begin system configuration, use the security tool provided to loosen the screw in the configuration door.

Note: The configuration door screw is a captive screw.

Note: The transmitter can only be configured for beam coding and Machine Test Signal. If neither of these configurations are required, then it is only necessary to configure the GuardShield PAC receiver.

Identify and set the appropriate dip-switches for the configuration desired.

Dip-switch identification and function is explained in the tables below.

Follow the Teach Function Procedure to reconfigure the GuardShield PAC.

IMPORTANT After each reconfiguration of the GuardShield PAC, test the system for proper configuration and operation before placing the guarded machine in operation.

When delivered from the factory, the following settings are configured.

Receiver—Factory Settings

Switch	Switch Function	Default Setting	Description
1	Mode Activation—Combination activates one of the following modes: Guard only, Start interlock, Restart Interlock	ON	Guard Only
2		ON	
3	MPCE Monitoring disable	ON	Disabled
4	Not used	OFF	
5	Not used	OFF	
6	Not used	OFF	
7	Set Beam Coding	OFF	Disabled
8	Not used	OFF	

Transmitter—Factory Settings

Switch	Switch Function	Default Setting	Description
1	Set Beam Coding	OFF	Disabled
2	Machine Test Signal	OFF	OFF: Signal High active—No connection or connect normally open ON: Signal Low active—Connect N/C

Settings for Mode of Operation—Receiver

Switch 1	Switch 2	Condition	Operation
ON	ON	Guard Only	ON/OFF Operation
OFF	ON	Start Interlock (Push Button Reset)	Interlock at start up—Reset by actuation of pushbutton switch
OFF	OFF	Restart Interlock	Interlock at interruption of sensing area—Reset by actuation of pushbutton switch
ON	OFF	Start Interlock	Interlock at start up—Reset by Interruption/restoration of sensing area for <1 sec

ATTENTION



Every modification at the DIP switches must be stored in the memory of the device through the Teach function. Simply changing the position of a dip switch will not change the GuardShield. It is necessary to first change the dip switch position and then perform the teach function. If the changes have been enabled in the GuardShield, the amber LED will flash three times as a visual confirmation that the change has been accepted.

IMPORTANT

GuardShield PAC light curtains with ArmorBlock Guard I/O connectivity are configured from the factory as standard GuardShield PAC light curtains. However, the only configurable functionality is beam coding. All other configurable functions have been disabled.

Teach Function

Procedure:

- Step 1** Open cover of the end cap (LED blinks: Receiver is red LED, Transmitter is amber LED).
- Step 2** Select the desired switch setting.
- Step 3** Press and hold the Teach button. The yellow LED flashes at 10 Hz (10x per second).

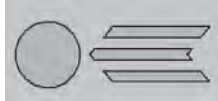

- Step 4** The yellow LED will stop blinking while the button is depressed. After the yellow stops flashing, release the teach button within 2 seconds.
- After 3 flashes of the yellow LED the function is activated.
- Step 5** Close and secure the cover.

IMPORTANT

The doors on the transmitter and receiver must be closed for the GuardShield PAC to operate.

If the GuardShield PAC teach procedure is not properly completed, the unit will remain in the previous operating mode.

Once the teach function is completed and the door secured, verify that the operating mode has changed to the intended mode.

Troubleshooting Guide

The light curtain carries out an internal self-test after startup. If an error occurs, an appropriate signal combination is sent through the LEDs to the transmitter and receiver.

Condition No.	Error Description	Action
6	Internal fault, receiver	<ul style="list-style-type: none"> • Check configuration of transmitter and receiver • Replace receiver
7	Internal fault, transmitter	<ul style="list-style-type: none"> • Check configuration of transmitter and receiver • Check protective field transmitter/receiver • Check connections transmitter/receiver • Exchange transmitter
8	External fault	<ul style="list-style-type: none"> • Check connections of OSSD outputs for short circuit against +24V DC and GND (cable, connected devices) • Exchange receiver
9	External fault (MPCE error) The function Relay monitoring is activated and after clearing the OSSD the input Relay monitoring does not recognize a change of state.	<ul style="list-style-type: none"> • Check connection Relay monitoring • Check connected relay for closed contact (if OSSD ON—input Relay monitoring must have GND level, if OSSD OFF—input Relay monitoring must have +24V) • Switch on only after POWER OFF/ON
10	Configuration mode (Receiver)	<ul style="list-style-type: none"> • Cover for DIP switch setting at the receiver is open
11	Configuration mode (Transmitter)	<ul style="list-style-type: none"> • Cover for DIP switch setting at transmitter is open

System Status Indicators



Condition No.	Receiver LEDs					Transmitter LEDs	
	OSSDs OFF Red	OSSDs ON Green	Yellow	Alignment Amber	Interlock Yellow	Power On Amber	Emitting Yellow
1	OFF	ON	OFF	OFF	OFF	ON	ON
2	ON	OFF	OFF	OFF	OFF	ON	ON
3	ON	OFF	OFF	ON	OFF	ON	ON
4	ON	OFF	OFF	OFF	ON	ON	ON
5	ON	OFF	OFF	OFF	OFF	ON	OFF
6	FLASH	OFF	OFF	OFF	OFF	ON	ON
7	ON	OFF	OFF	OFF	OFF	FLASH	ON
8	FLASH	OFF	OFF	ON	OFF	ON	ON
9	FLASH	OFF	OFF	OFF	ON	ON	ON
10	FLASH	OFF	DATA TRANS ①	OFF	OFF	ON	ON
11	ON	OFF	OFF	OFF	OFF	FLASH	DATA TRANS ①

6 through 11 = Fault conditions

① Data transmission—factory configuration interface—not available for use outside factory

Flash rate is approximately .2 Hz (2 times per second)

Condition No.	Description
1	Guard only mode, light curtain unobstructed (aligned, not in interlock)
2	Guard only mode, light curtain interrupted (aligned, not in interlock)
3	Guard only mode, misaligned (not in interlock)
4	In start or restart interlock (aligned)
5	Transmitter test input active (pin 4)
6	Internal fault, receiver
7	Internal fault, transmitter
8	External fault (OSSD short to ground, +V, or cross connection)
9	External fault (MPCE/EDM error)
10	Configuration mode (receiver access door open)
11	Configuration mode (transmitter access door open)

Note: Note: For fault conditions 6 through 11, see Troubleshooting guide on page 20.

ATTENTION



Assure that all power to the machine, and safety system is disconnected during electrical installation.

IMPORTANT

Prior to powering up the GuardShield PAC system, the responsible person should review the following Checklist.

Checklist

Before the initiation of the GuardShield PAC the responsible person should work through the following checklist.

Cable check prior to initiation:

- o The power supply is solely connected to the GuardShield PAC.
- o The power supply is a 24V DC device, that must comply to all applicable standards of the Machinery Directive 2006/42/EC, and the product standard (IEC 61496).
- o Proper polarity of the power supply at the GuardShield PAC.
- o The transmitter connection cable is properly connected to the transmitter, the receiver connection cable is properly connected to the receiver.
- o The double insulation between the light curtain output and an external potential is ensured.
- o The OSSD outputs are not connected to +24V DC.
- o The connected switching elements (load) are not connected to 24V DC.
- o No connection to a conventional power supply.
- o If two or more GuardShield PAC are to be used, make sure that each system is properly installed, in order to avoid optical interference.

Switch the GuardShield PAC on and check its function by observing the following:

- o 2 seconds after switching on, the system starts to work properly, if the protective field is free of obstructions.

Safety Instructions—Maintenance

ATTENTION

Never operate the GuardShield PAC before carrying out the following inspection. Improper inspection can lead to serious or even deadly injury.

Note:

1. For safety reasons all inspection results should be recorded.
2. Only persons, who clearly understand the functioning of the GuardShield PAC and of the machine, may carry out an inspection.
3. If installer, planning engineer and operator are different people, make sure that the user has sufficient information available to carry out the inspection.

Daily Inspection

- o Approach to hazardous machine parts must only be possible through the protective field of GuardShield PAC.
- o Operators cannot step through the sensing area while working on dangerous machine parts.
- o The safety distance of the application is bigger than the calculated value.
- o The optic front cover is neither scratched nor dirty.

Operate the machine and check, if the hazardous movement will stop under the following circumstances.

- o The protective field is interrupted.
- o Hazardous machine movement stops immediately, if the protective field is interrupted by the test rod directly in front of the transmitter, directly in front of the receiver and in the middle between transmitter and receiver.
- o No hazardous machine movement while completely interrupting any of the PAC beams.
- o The power supply of the GuardShield PAC is turned off.

IMPORTANT

If any of the above conditions do not result in the hazardous motion of the machine ceasing, do not allow the protected machine to be placed in operation.

Six-Month Inspection



Check the following items every six months or whenever a machine setting was changed.

1. o Machine stops or does not obstruct any safety function.
2. o The latest machine or connection modifications have no effect on the control system.
3. o The outputs of the GuardShield PAC are properly connected to the machine.
4. o The total response time of the machine is shorter than the calculated value.
5. o Cables and plugs of the GuardShield PAC are in flawless condition.
6. o Mounting brackets, caps and cables are tightly secured.

Cleaning

If the optic front cover of the GuardShield PAC is dirty, the outputs of the GuardShield PAC may turn off. Take a clean, soft cloth and rub without pressure. Do not apply aggressive, abrasive or scratching cleansing agents, which might attack the surface.

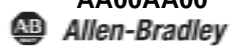
Date Code

Bul/Type	440L	Ser Rev		Ambient Temp	-10.....+55C
Part No.	R4A2500YD	A B		Power Consumption	7W max.
Ref No.	AA00AA00	Made in	Jun, 2010	Supply Voltage	24V DC +/-20%
 AA00AA00  GuardMaster Rockwell Automation 2 Executive Dr. Chelmsford MA. 01824 978-441-9500 Product of Mexico			Safety Parameters	Type 4/Cat.4	
 CE  cUL LISTED Electro-Sensitive Protective Equip. 19KP			Operating Instructions	PN-11790	
Bul/Type	440L	Ser Rev		Degree of Protection	IP65
Part No.	R4A2500YD	A B		# of Beams/Spacing	2/520mm
			Range	0.3-16m	
			Protective Height	500mm	
			Response Time with Coding	<30ms	
			Response Time w/o Coding	<20ms	

Location of Manufacture	Year of Manufacturer	Week of Manufacturer
X	X*	XX
M or 4K	R	02
M represented Manchester, NH replaced by 4K for Monterrey, Mexico		
* J=2004		S=2011
K=2005		T=2010
L=2006		U=2013
M=2007		V=2014
N=2008		W=2015
P=2009		Y=2016
R=2010		Z=2017

Figure 4: Explanation of data code

Technical Specifications

Light Beams		3/400 mm spacing (440L-P4A3400YD)2/500 mm spacing (440L-P4A2500YD)
Protective Field		820 mm (31.8 in.) 3 beam, 520 mm (20.4 in.) 2 beam
Range		16 m (52.5 ft)
Response Time		OSSD – ON to OFF: (Reaction times); 20 ms uncoded; 30 ms coded
Power Supply		24V DC +/-20%; Power supply must meet the requirements of IEC 60204-1 and IEC 61496-1.
Power Consumption		400 mA max. (unloaded)
IR Transmitter		Infrared LED (wave length 870 nm)
Aperture Angle		Within ± 2.5° for transmitter and receiver
Operating Condition		IR transmitter ON
Functions		<p>Guard Only: On/Off operation with clear/obstructed detection area</p> <p>Start Interlock: Interlock at start up—Reset by actuation of momentary N.O. pushbutton switch (or interruption/restoration of light curtain)</p> <p>Restart Interlock: Interlock at interruption of sensing field—Reset by actuation of momentary N.O. pushbutton switch</p> <p>Relay Monitoring: Monitoring a switch contact of the installation</p> <p>Coding: May be necessary for multiplex alignment</p> <p>Test Function: Triggering of system test via external switch</p>
Inputs Transmitter	Machine Test Signal	<p>Minimum duration 100 ms</p> <p>Voltage level for Logic 0: 0 – 5V DC Voltage level for Logic Hi 1: > 16V DC</p>
Inputs Receiver	Start/Restart Interlock	<p>Logic Lo</p> <p>Minimum duration 100ms; maximum duration 900 ms</p> <p>Voltage level for Logic Lo 0: 0 – 5V DC Voltage level for Logic Hi 1: > 16V DC</p>
	MPCE	<p>300 ms after activation of OSSD</p> <p>Voltage level for Logic 0: 0 – 5V DC Voltage level for Logic Hi 1: > 16V DC</p>
Outputs:	Safety Outputs (OSSDs)	Two solid state outputs, max. switching capacity 500 mA (resistive/inductive), short circuit protected, max. residual voltage 2V (excl. voltage drop through cables)
	Auxiliary Output	Solid state output, max. power consumption 500 mA (resistive/inductive), max. residual voltage 2V—nonsafety output Max. Off State leakage current: 1 mA Max. Capacitive Load: 0.18 uF
Status Indicators Receiver	ON-state	Constant ON when system is in ON-state (green LED)
	OFF-state	Constant ON when system is in OFF-state (red LED)
	Alignment Interlock	<p>Lights up, if input signal is too weak (amber LED)</p> <p>Lights up when light curtain is in start or restart interlock mode (yellow LED)</p>
Status Indicators Sender	Power ON Emitting	<p>Lights up, when voltage is on (amber LED)</p> <p>Constant ON when transmitter is active (yellow LED)</p>
QD Connectors		Transmitter: M12 plug 4 pin; receiver: M12 plug 8 pin for standard GuardShield PAC and PAC with integrated laser alignment system, GuardShield PAC with ArmorBlock I/O 5-pin M12
Cable Length		Maximum 30 m (100 ft), Maximum resistance: 5 ohms
Ambient Temperature		During operation: –10...55°C (14...131°F); For storage: –25...75°C (–13...167°F)
Humidity of the Air		Up to 95% (without condensation) between 20...55°C (68...131°F)
Enclosure Rating		IP65
Vibration Resistance		Per IEC 61496-1, IEC 60068-2-6 Frequency 10...55 Hz Amplitude 0.35 mm
Shock		Per IEC 61496-1, IEC 60068-2-29 Acceleration 10 g, Duration 16 ms
Material		Housing: Aluminum; Cover: PMMA (acrylic)
Dimensions (cross section)		Approx. 40 mm x 50 mm (1.57 in. x 1.96 in.)
Accessories Included		Mounting brackets, operating instructions, security tool, plastic tool for setting dipswitch and teach function
Approvals		IEC 61496 Parts 1 and 2, UL 61496 Parts 1 and 2, UL 1998
Safety Classification		Type 4 per EN/IEC 61496, category 4 EN/ISO 13849; SIL 3, IEC 61508, SIL CL3 EN 62061, PL e, EN/ISO 13849
PFHd (mean probability of a dangerous failure/hr		Standalone sys.: 9.51×10^{-9} ; Cascading sys. (host/guest): 1.95×10^{-8} ; Cascading sys. (host/guest/guest): 2.75×10^{-8}
T _M (mission time)		20 years (EN ISO 13849)
Transmitter Wave Length		870 nm

GuardShield PAC standard

Cat. No.	Beam Spacing	No. of Beams	Protective Height [mm (in.)]
440L-P4A2500YD	500	2	520 (20.4)
440L-P4A3400YD	400	3	820 (32.2)

Note: GuardShield PAC light curtains are sold in pairs. To select a transmitter or receiver, replace the “P” in the cat. no. with a “T” for the transmitter and an “R” for the receiver.

GuardShield PAC with Integrated Laser Alignment

Cat. No.	Beam Spacing	No. of Beams	Protective Height [mm (in.)]
440L-P4AL2500YD	500	2	520 (20.4)
440L-P4AL3400YD	400	3	820 (32.2)

Note: GuardShield PAC with integrated laser alignment are sold in pairs. To select a transmitter or receiver, replace the “P” in the cat. no. with a “T” for the transmitter and an “R” for the receiver.

GuardShield PAC with Integrated Laser Alignment and I/O Connectivity

Cat. No.	Beam Spacing	No. of Beams	Protective Height [mm (in.)]
440L-P4AL2500YA	500	2	520 (20.4)
440L-P4AL3400YA	400	3	820 (32.2)

Note: GuardShield PACs with ArmorBlock Guard I/O Connectivity are sold in pairs. The pair consists of a standard GuardShield PAC with integrated laser alignment transmitter with 4 pin M12 quick-disconnect (440L-T4AXXXYD). To select a receiver, replace the “P” in the cat. no. with an “R” for the receiver.

Cat. No. Explanation

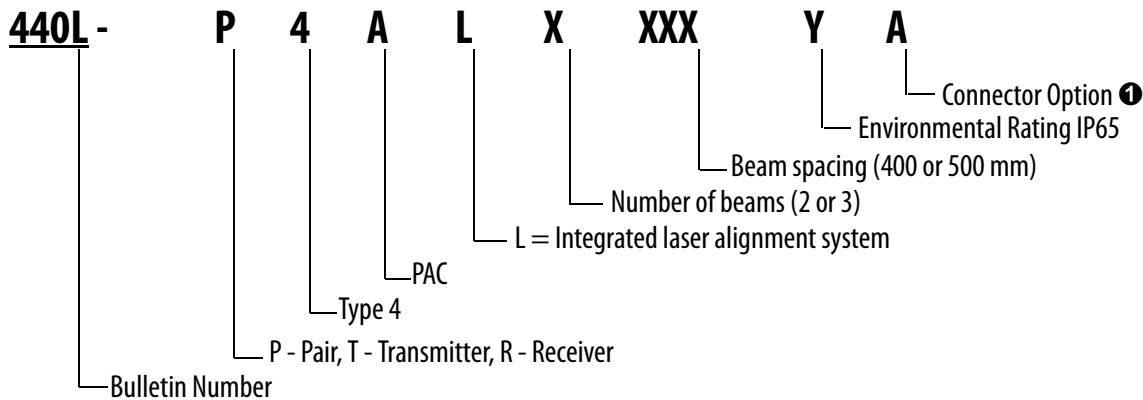
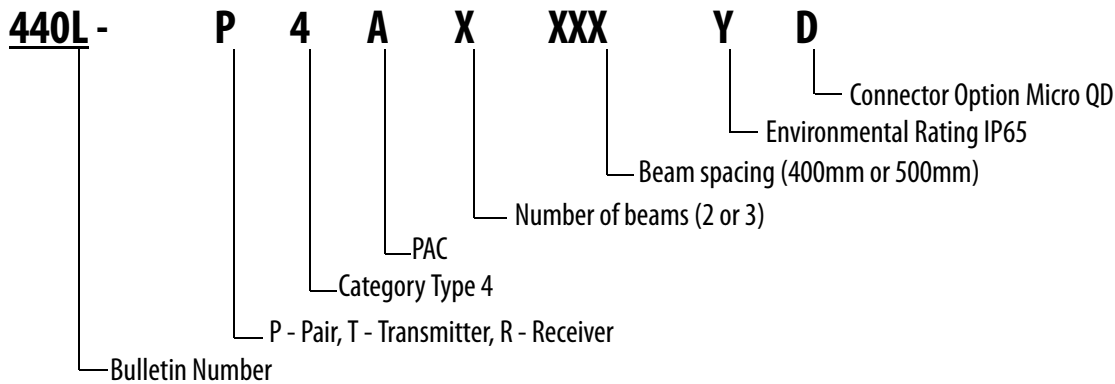

① D for M12 QD and A for 5-pin M12 for ArmorBlock Guard I/O

Bill of Material for 3-sided guarding using pedestal floor stands and corner mirrors with a GuardShield 3-beam PAC without cordsets.

	Qty.	Description	Cat. No.
	1	GuardShield three-beam PAC pair	440L-P4A3400YD
	2	Narrow 1050 mm corner mirror	440L-AM0751050
		Wide 1050 mm corner mirror	440L-AM1251050
	4	Pedestal floor stand	440L-AMSTD

Dimensions [mm (in.)]

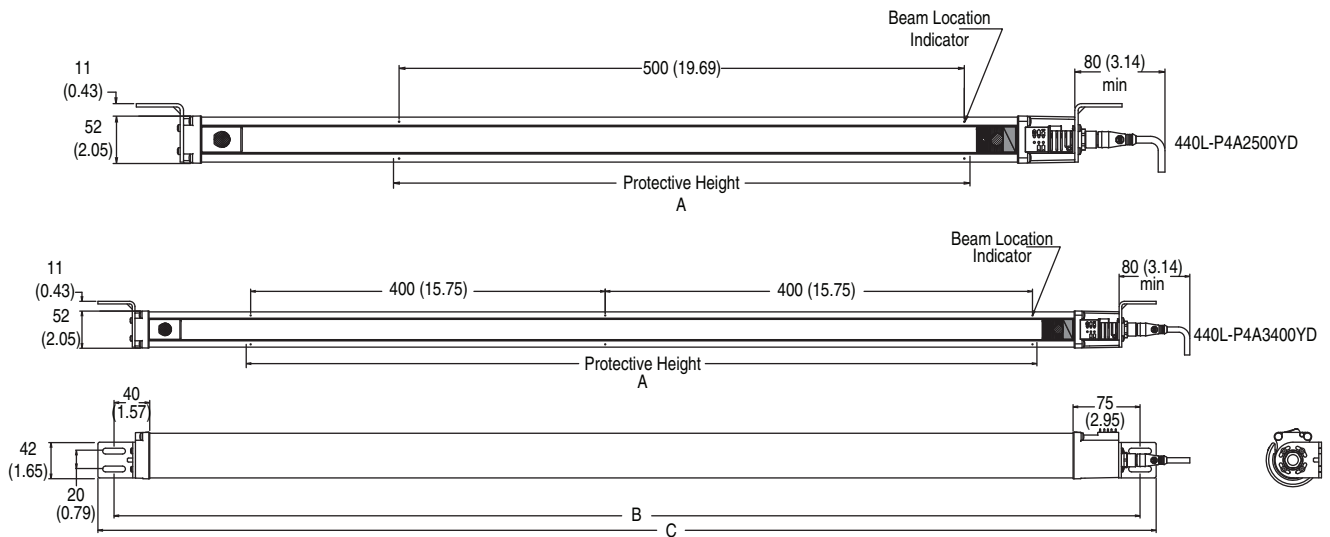

A Protective Height [mm (in.)]	B Mounting Value [mm (in.)]	C Total Length [mm (in.)]	Cat. No.
820 (32.3) ±0.02	1076 (42.4)	1112 ±1.5 (43.8) ±0.06	440L-P4A2500YD
520 (20.5) ±0.02	756 (29.8)	792 ±1.5 (31.2) ±0.06	440L-P4A3400YD

GuardShield™ PAC Safety Light Curtain Installation Instructions

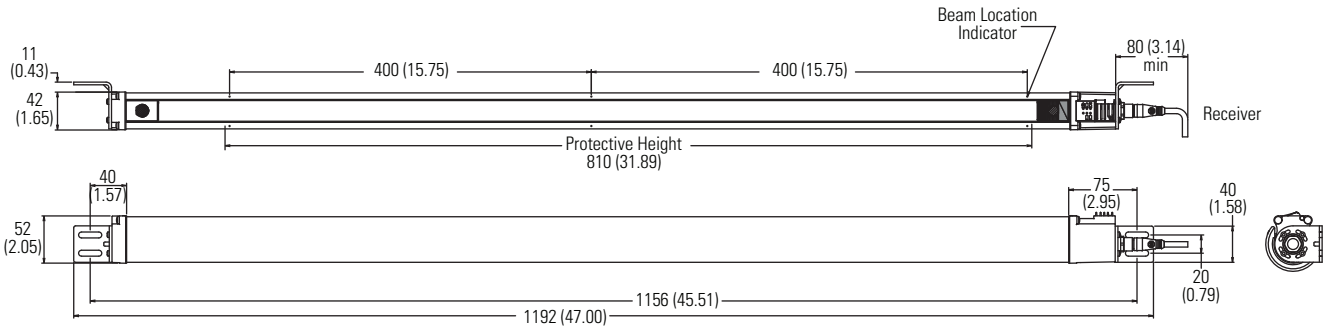

440L-P4A3400YD consists of a pair
440L-T4A3400YD transmitter & 440L-R4A3400YD receiver

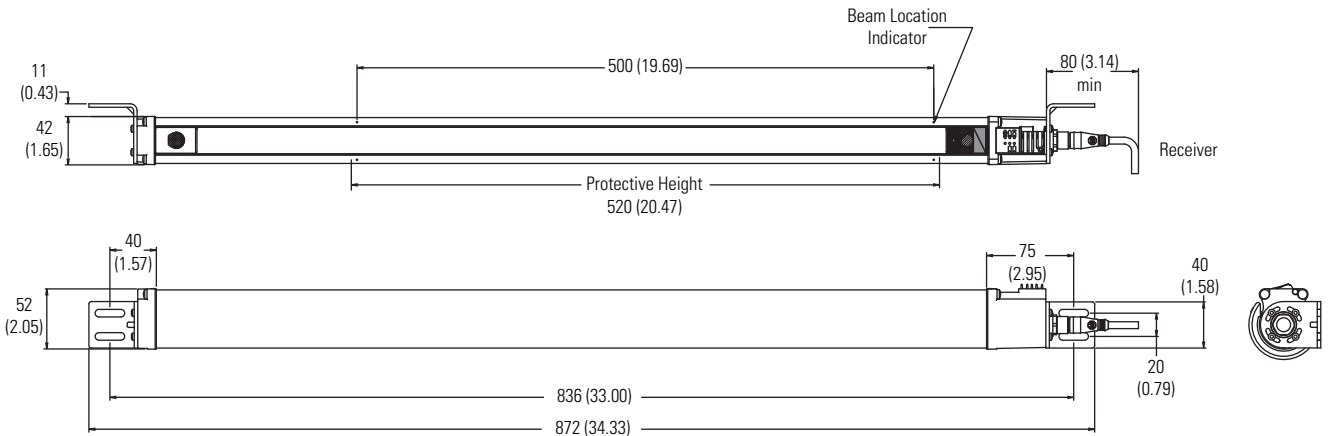
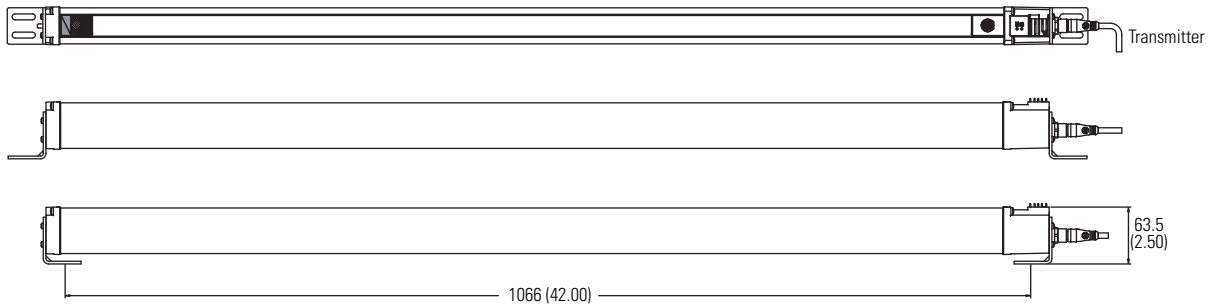

440L-P4A2500YD consists of a pair
440L-T4A2500YD transmitter & 440L-R4A2500YD receiver

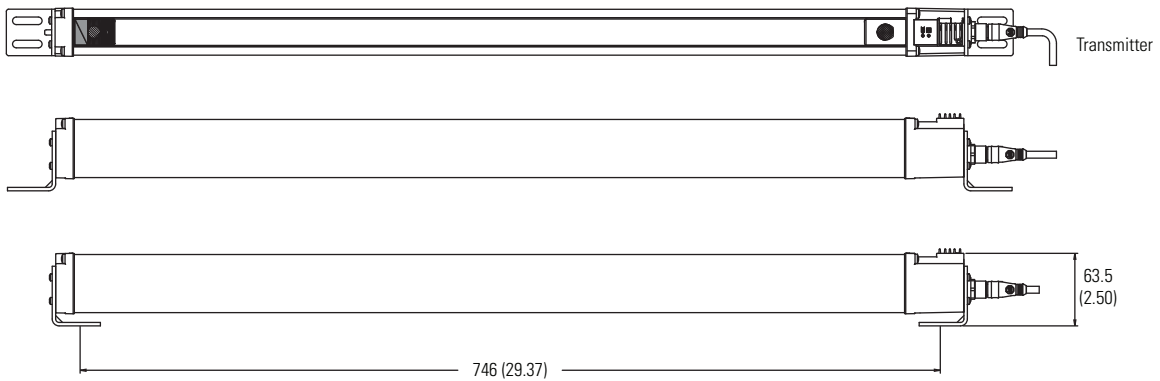

Accessories

Corner Mirrors

Narrow

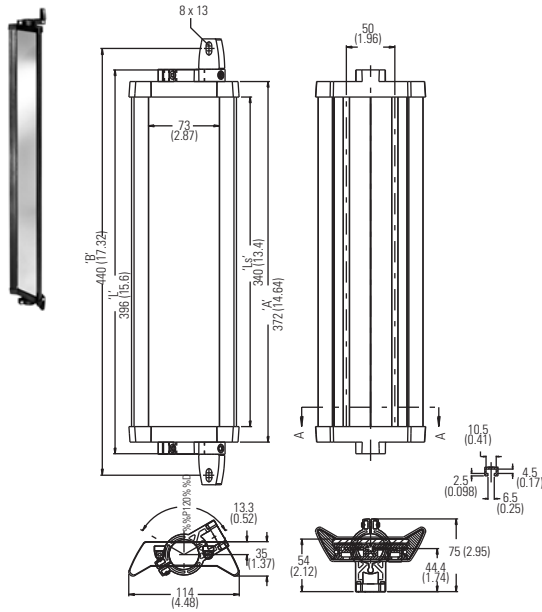

Wide

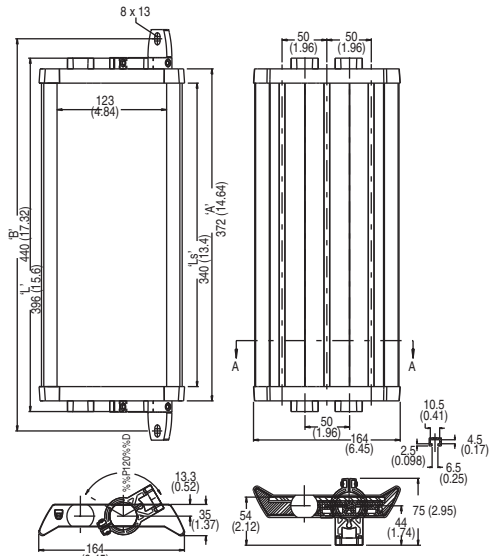

Light Curtain Cat. No.	Mirror Cat. No.
440L-P4A3400YD 440L-P4AL3400YD 440L-P4AL3400YA	Narrow—440L-AM0751050 Wide—440L-AM1251050
440L-P4A2500YD 440L-P4AL2500YD 440L-P4AL2500YA	Narrow—440L-AM0750750 Wide—440L-AM1250750

GuardShield 2- and 3-beam light curtain PAC mounting and mirror columns Stand—440L-AMSTD

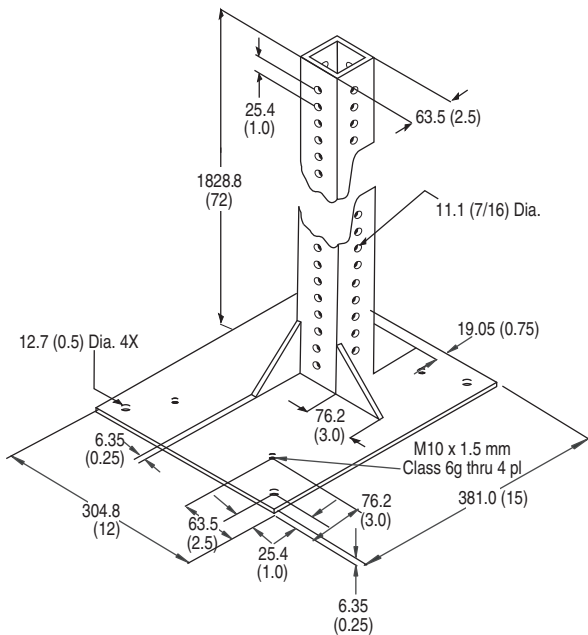

Note: Two GuardShield mounting brackets are supplied with each 440L-AMSTD floor stand.

Figure 5: Pedestal floor stand

GuardShield Washdown Enclosures

	Cat. No.	
	PAC	Enclosure Kit
	440L-P4A3400YD	440L-AGST960
	440L-P4A2500YD	440L-AGST640

Note: The GuardShield washdown enclosures are designed for use with standard GuardShield PAC light curtains only.

Laser Alignment Tool (used on standard GuardShield)

Requires 440L-AF6109 bracket to mount to front of GuardShield PAC

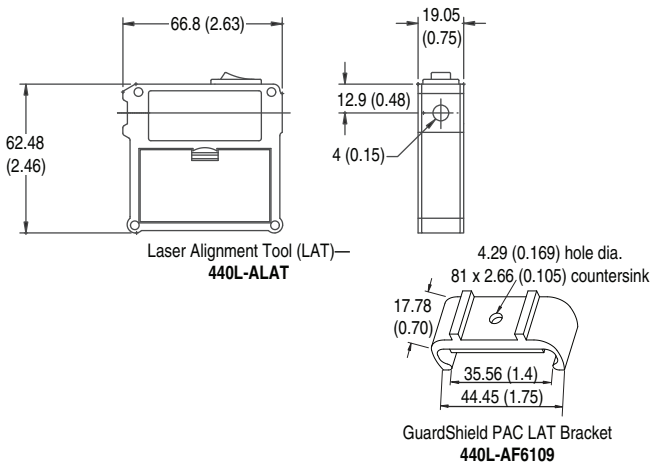

Weld Shields

The GuardShield PAC weld shields are sold as pairs.

These polycarbonate weld shields are designed as disposable devices whose purpose is to protect the front window of the GuardShield PAC from damage.

Dimensions [mm (in.)]

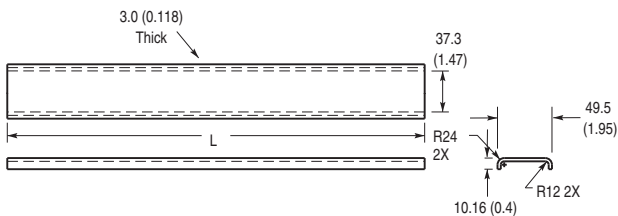

GuardShield PAC Weld Shield

GuardShield PAC Cat. No.	GuardShield Weld Shield Cat. No.	Dimension "L" [mm (in.)]
440L-P4A2500YD	440L-AGWS0640	655.3 (25.8)
440L-P4A3400YD	440L-AGWS0960	975.4 (38.4)
440L-P4AL2500YD	440L-AGWS0800	815.3 (32.1)
440L-P4AL2500YA		
440L-P4AL3400YD	440L-AGWS1120	1135.4 (44.7)
440L-P4AL3400YA		

GuardShield PAC ArmorBlock Connectivity

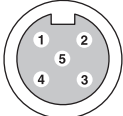
Top View	Color	Pin No	Signal
			Receiver
	Brown	1	+ 24V
	White	2	OSSD 2
	Blue	3	0 V
	Black	4	OSSD 1
	Gray	5	NC

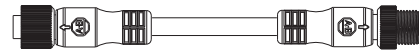

Example of Patchcord

Interconnecting Patchcords— ArmorBlock I/O Connection

Cat. No.	Description
889D-F5ACDM-0M3	5-pin M12 patchcord, 12 inches
889D-F5ACDM-1	5-pin M12 patchcord, 1 meter
889D-F5ACDM-2	5-pin M12 patchcord, 2 meters
889D-F5ACDM-5	5-pin M12 patchcord, 5 meters
889D-F5ACDM-10	5-pin M12 patchcord, 10 meters

IMPORTANT

The GuardShield PAC pair with ArmorBlock Guard I/O Connectivity has a five-pin M12 quick-disconnect connector on the receiver wired to connect to the ArmorBlock five-pin connector. The transmitter in that GuardShield pair is a standard GuardShield PAC transmitter with integrated laser alignment system offered with a four-pin M12 quick-disconnect connector. It is possible to connect either a standard four-pin M12 cordset or the five-pin M12 quick-disconnect connector patchcord to this transmitter.

GuardShield PAC Cordsets

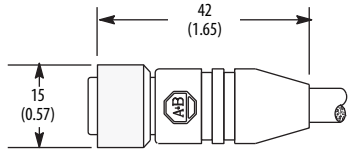

For Connection to GuardShield PAC and GuardShield PAC with Integrated Laser Alignment

Cat. No.	Description [m (ft)]
889D-F8AB-2	8-pin DC Micro Straight Female Cordset, 2 (6.5)
889D-F8AB-5	8-pin DC Micro Straight Female Cordset, 5 (16.4)
889D-F8AB-10	8-pin DC Micro Straight Female Cordset, 10 (32.8)
889D-F8AB-15	8-pin DC Micro Straight Female Cordset, 15 (49.2)
889D-F8AB-20	8-pin DC Micro Straight Female Cordset, 20 (65.6)
889D-F8AB-30	8-pin DC Micro Straight Female Cordset, 30 (98.4)

For Connection to GuardShield PAC Transmitters

Cat. No.	Description
889D-F4AC-2	4-pin DC Micro Straight Female Cordset, 2 (6.5)
889D-F4AC-5	4-pin DC Micro Straight Female Cordset, 5 (16.4)
889D-F4AC-10	4-pin DC Micro Straight Female Cordset, 10 (32.8)
889D-F4AC-15	4-pin DC Micro Straight Female Cordset, 15 (49.2)
889D-F4AC-20	4-pin DC Micro Straight Female Cordset, 20 (65.6)
889D-F4AC-30	4-pin DC Micro Straight Female Cordset, 30 (98.4)

EC Declaration of Conformity

The undersigned, representing the manufacturer

Rockwell Automation, Inc.
2 Executive Drive
Chelmsford, MA 01824
USA

and the authorised representative established within the
Community

Rockwell Automation BV
Rivium 1e Straat, 23
2209 LE Capelle aan den IJssel
Netherlands

Herewith declare that the Products:
Product identification (brand and
catalogue number/part number):

GuardShield™ Type 4 Safety Light Curtains
Allen-Bradley / Guardmaster 440L Series
(reference the attached list of catalogue numbers)

Product Safety Function:

440L Series Type 4 safety light curtains are active optoelectronic protection devices (AOPDs) with resolutions of 14mm and 30mm, or multiple beams with various beam spacings. These safety light curtains are self-checking and cascable, and are suitable for applications up to Safety Category 4 (EN ISO 13849-1) and SIL3 (EN 61508).

are in conformity with the essential requirements of the following EC Directive(s) when installed in accordance with the installation instructions contained in the product documentation:

2004/108/EC

EMC Directive

2006/42/EC

Machinery Directive

and that the standards and/or technical specifications referenced below have been applied:

EN 55022:1998 +A1:2000
+A2:2003

Information technology equipment – Radio disturbance characteristics -
Limits and methods of measurement

EN 61496-1:2004 + A1:2008

Safety of machinery – Electro-sensitive protective equipment – Part 1: General
requirements and tests

CLC/TS 61496-2:2006
IEC 61496-2:2006

Safety of machinery – Electro-sensitive protective equipment – Part 2:
Particular requirements for equipment using active opto-electronic protective
devices (AOPDs)

EN 61508:2001

Functional safety of electrical/electronic/programmable electronic safety-
related systems

EN 62061:2005

Safety of machinery – Functional safety of safety-related electrical, electronic
and programmable control systems

EN ISO 13849-1:2008 / AC:2009

Safety of machinery – Safety related parts of control systems – Part 1: General
principles for design

The authorised representative is authorized to compile the Technical File.

Conformance of a type sample belonging to the above mentioned product family with the regulations from the EC
Machinery Directive has been certified by:

TÜV NORD CERT GmbH & Co.
KG
Langemarckstr. 20, D-45141
Essen, Germany
ID-No.: 0044

EC Type Examination Certificate No.
44 205 10 383326 000

Manufacturer:

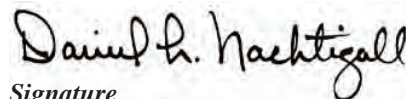

Signature

Name: Daniel L. Nachtigall

Position: Technical Leader – Certification Engineering

Date: 17-Jun-2010

Place: Milwaukee, WI USA

Authorised Representative in the Community:

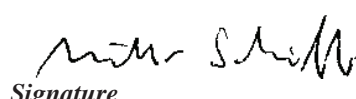

Signature

Name: Viktor Schiffer

Position: Engineering Manager

Date: 21-Jun-2010

Place: Haan, Germany

Document Control Number: SEN-0339-H-EN (Original)

1 / 2

Catalogue number	Series ¹	Description
440L-*4*****		GuardShield Type4 light curtains per Nomenclature

1) If no series number is given, then all series are covered

MODEL NOMENCLATURE:

440L	-	P	4	J	L	1600	Y	D
1		2	3	4	5	6	7	8

1	Designates Product Type 440L – GuardShield safety light curtains
2	Light Curtain Type P – Transmitter/receiver pair C – Cascaded sensor pair R – Receiver F – Cascaded receiver T – Transmitter G – Cascaded transmitter S – Remote Teach System
3	Optoelectronic Safety Type 4 – Type 4
4	Beam Resolution J – 14mm K – 30mm A – Perimeter Access Control
5	Electronic Unit Type Blank – Standard L - Laser
6	Protection Height or Number of Beams and Beam Gap 0160 – 160mm height 1120 – 1120mm height 0320 – 320mm height 1280 – 1280mm height 0480 – 480mm height 1440 – 1440mm height 0640 – 640mm height 1600 – 1600mm height 0800 – 800mm height 2500 – Two beams, 500mm gap 0960 – 960mm height 3400 – Three beams, 400mm gap
7	Environmental Rating Y – IP65
8	Connection Options A – 5 pin, M12 quick disconnect D – Micro quick disconnect connector R – Pigtail w/Y-connector cable

GuardShield is a trademark of Rockwell Automation, Inc.

www.rockwellautomation.com

Power, Control and Information Solutions Headquarters

Americas: Rockwell Automation, 1201 South Second Street, Milwaukee, WI 53204 USA, Tel: (1) 414.382.2000, Fax: (1) 414.382.4444

Europe/Middle East/Africa: Rockwell Automation, Vorstlaan/Boulevard du Souverain 36, 1170 Brussels, Belgium, Tel: (32) 2 663 0600, Fax (32) 2 663 0640

Asia Pacific: Rockwell Automation, Level 14, Core F, Cyberport 3, 100 Cyberport Road, Hong Kong, Tel: (852) 2887 4788, Fax: (852) 2508 1846