



## Next Generation Guardmaster Safety Relay (GSR)

Bulletin 440R

### Quick Reference

Page	Safety Relay Modules	Input Devices	Output Devices	SIL CL	Category Number	PL	Stop Cat.
<a href="#">6</a>	SI	E-stop	PowerFlex 525	2	3	d	0
<a href="#">8</a>	SI	MAB	PowerFlex 525	2	3	d	0
<a href="#">10</a>	SI	Trojan T15	1794 FLEX I/O	2	3	d	0
<a href="#">12</a>	SI, EM, EMD	4 E-stops	100S-C, 700S-DCP	2	3	d	0
<a href="#">14</a>	SI, EMD	E-stop	Kinetix 6000 Guardmotion with RBM	3	4	e	1
<a href="#">16</a>	SI, EMD	GuardShield Safe 4	100S, 700S-C	3	4	e	0
<a href="#">18</a>	SI, DI, DIS	3 E-stops, Trojan T15, Safety Mat	100S, 700S-C	3	4	e	0
<a href="#">20</a>	SI, MSR35H	GuardShield, 800Z	100S-C	3	4	e	0
<a href="#">22</a>	SI, DIS	3 SensaGuard with Integrated Latch, 2 E-stops	PowerFlex 525	3	4	e	0
<a href="#">24</a>	CI	Trojan T15, Elf, E-stop, PLC on Ch2	100S-C	2	3	d	0
<a href="#">26</a>	CI	3 SensaGuard	100S-C	3	4	e	0
<a href="#">28</a>	CI	3 MC2 Magnetically Coded Sensors	100S-C	2	3	d	0
<a href="#">30</a>	CI	3 Ferrogard GD2 Non-contact Sensors	100S-C	2	3	d	0
<a href="#">32</a>	DI	GuardShield	100S-C	3	4	e	0
<a href="#">34</a>	DI	2 GuardShield	100S-C	3	4	e	0
<a href="#">36</a>	DI	2 Lifeline 4	100S-C	3	4	e	0
<a href="#">38</a>	DI	5 SensaGuard, Distribution Block, E-stop	Kinetix K350	2	3	d	0
<a href="#">40</a>	DI	GuardShield, E-stop	Pneumatic Safety Valve	3	4	e	0
<a href="#">42</a>	DI	SensaGuard with Integrated Latch, E-stop	PowerFlex 525	2	3	d	0
<a href="#">44</a>	GLT, EM, SI, EMD	440G-MT, MT-GD2, Grip Enabling Switch	100S-C	2	3	d	0
<a href="#">46</a>	DI, EMD	MT-GD2, Grip Enabling Switch-Jog	PowerFlex 70	2	3	d	0
<a href="#">48</a>	DI, EMD	TLS1-GD2, Trojan T15, E-stop	100S-C	3	4	e	0
<a href="#">50</a>	DI, EMD	MAB, E-stop	100S-C	2	3	d	0
<a href="#">52</a>	DI, DI, DI	2 E-stops, 2 GuardShield Safe 4, Mat, SensaGuard	100S-C	2/3	3/4	d/e	0
<a href="#">54</a>	DI	2 Safety Mats	PowerFlex 755	2	3	d	0
<a href="#">56</a>	DI	SafeZone Mini, E-stop	Kinetix 350	2	3	d	0
<a href="#">58</a>	DI	SafeZone Multizone, E-stop	Kinetix 350	2	3	d	0
<a href="#">60</a>	DI	SC300 Safety Sensor, E-stop	Kinetix 350	2	3	d	0
<a href="#">62</a>	DIS	Galvanic Isolator 937TH, Trojan T15, E-stop	PowerFlex 525	2	3	d	0

LISTEN.  
THINK.  
SOLVE.™

Page	Safety Relay Modules	Input Devices	Output Devices	SIL CL	Category Number	PL	Stop Cat.
<a href="#">64</a>	DIS	Galvanic Isolator 937TH, MatGuard, E-stop	PowerFlex 525	2	1/3	c/d	0
<a href="#">66</a>	DIS	Galvanic Isolator 937TH, Safedge, E-stop	PowerFlex 525	2	1/3	c/d	0
<a href="#">68</a>	DIS	Trojan 5, MT-GD2	PowerFlex 70	2	3	d	0
<a href="#">70</a>	DIS	Trojan 5	2 PowerFlex 70	2	3	d	0
<a href="#">72</a>	DIS, MSR41	Micro 400 GuardShield, E-stop	100S-C	3	4	e	0
<a href="#">74</a>	DIS, MSR42	Micro 400 GuardShield, SensaGuard, E-stop	100S-C	3	4	e	0
<a href="#">76</a>	GLP	872C, TLS3-GD2, GLP Logic = 1	PowerFlex 70	2	3	d	1
<a href="#">78</a>	GLP	872C, TLS-ZR, GLP Logic = 1	1734 POINT Guard I/O	2	3	d	1
<a href="#">80</a>	GLP, EM	871TM, 440G-MT, 700-HPS, GLP Logic = 1	PowerFlex 525	2	3	d	1
<a href="#">82</a>	GLP, SI	871TM, 440G-LZ, E-stop, GLP Logic = 2	PowerFlex 70	2	3	d	1
<a href="#">84</a>	GLP	871TM, TLS-ZR, GLP Logic = 3	Kinetix 300	2	3	d	SLS
<a href="#">86</a>	GLP, SI, EM	871TM, 440G-LZ, E-stop, GLP Logic = 4	PowerFlex 525	2/3	3/4	d/e	SLS
<a href="#">88</a>	GLP, EM	872C, 440G-LZ, GLP Logic = 5 Stop Motion + Unlock Delay	—	2	3	d	—
<a href="#">90</a>	GLP	872C, GLP Logic = 5 Stop Motion Only	1734 POINT Guard I/O	2	3	d	—
<a href="#">92</a>	GLP	872C, GLP Logic = 8 Status Only	—	2	3	d	—
<a href="#">94</a>	GLT	TLS3-GD2, GLT Logic = 1	PowerFlex 525	2	3	d	0
<a href="#">96</a>	GLT	440G-LZ, GLT Logic = 1	PowerFlex 525	2	3	d	0
<a href="#">98</a>	GLT	Multiple 440G-LZ or TLS-ZR, GLT Logic = 1	PowerFlex 525	2	3	d	0
<a href="#">100</a>	GLT	Multifunction Access Box (MAB) GLT Logic = 1	PowerFlex 525	2	3	d	0
<a href="#">102</a>	GLT, SI	MAB with three buttons, GLT Logic = 2	100S	3	4	e	0
<a href="#">104</a>	GLT	TLS-ZR or 440G-LZ, GLT Logic = 3	PowerFlex 525	2	3	d	1
<a href="#">106</a>	GLT, SI	E-stop, TLS-ZR, or 440G-LZ, GLT Logic = 4	PowerFlex 525	2	3	d	1
<a href="#">108</a>	GLT, EM	E-stop, GLT Logic = 5	PowerFlex 525, 100S, 700S-C	2/3	3/4	d/e	1/0
<a href="#">110</a>	GLT, SI	MC2, E-stop, GLT Logic = 6	PowerFlex 525, 100S	2	3	d	1
<a href="#">112</a>	GLT, EM	E-stop, GLT Logic = 7	PowerFlex 525, 100S, 700S-C	2/3	3/4	d/e	1/0
<a href="#">114</a>	GLT, SI	Ferrogard GD2, E-stop, GLT Logic = 8	PowerFlex 525, 100S	3	4	e	1
<a href="#">116</a>	ENETR	DI, EM, DIS, EMD, GLT, GLT	—	—	—	—	—
<a href="#">118</a>	SI, EM	E-stop, SI, EM	100S-D	3	4	e	0
<a href="#">120</a>	GLP	SensaGuard with Integrated Latch	PowerFlex 70	2	3	d	SLS

## Summary of Changes

This publication contains an updated schematic and description in the [Stop Motion with Guard Locking and E-stop](#) section on [page 88](#).

## Notes for Example Wiring Diagrams

### Note 1

In the wiring diagrams that are shown in this publication, the type of Allen-Bradley® Guardmaster® device is shown as an example to illustrate the circuit principle. For special applications, the choice of device type is based on the suitability of its characteristics for its intended use.

### Note 2

In most of the following examples that show dual channel applications, one interlock switch is shown switching both channels (one contact set per channel). If foreseeable damage (for example, at the actuator mounting point) could allow the guard to be opened without operating the switch, then two separate switches are required. The electrical principle of the circuit remains the same.

### Note 3

In most cases, the circuits are shown with the guard door closed and ready for motor starting by operating the normal start control.

It must be possible to start the machine only by voluntary actuation of the control that is provided for the purpose (see ISO 12100-2 4.11.8). For the purposes of these examples, the use of a conventional contactor-latching circuit has been assumed. If not, then a restart interlock is required to help prevent an automatic or unintended starting of the motor when the guard is closed. For example, a Minotaur™ safety relay with a momentary action push button that is installed in the output to monitor the circuit can be used to achieve this protection.

If the guard is designated as a Control Guard (see ISO 12100-2 5.3.2.5), these requirements do not apply. However, the use of control guards is allowed only under certain conditions including:

- A control guard can be used only where there is no possibility of an operator or part of their body staying in or reaching into the danger zone while the guard is closed.
- The control guard must be the only access to the hazardous area.
- The interlocking system must have the highest possible reliability. It is often advisable to use a solenoid locking switch such as the Guardmaster 440G-LZ or TLS-ZR guard locking switches.

**Note 4**

Safety monitoring relays are used in dual-channel circuits with infrequent operation or with multiple switching devices connected. This note applies to all monitoring devices that compare the signal at the change of state of dual channels.

Certain faults are only detected at a change of state of the input switching device (interlock switch or E-stop switch). If there are long periods (for example, months as opposed to days) between switching actions, it is possible for multiple faults to accumulate, which could lead to a dangerous situation. Therefore, a regular check must be performed on the system to detect single faults before an accumulation occurs. This check can be manual or initiated by part of the control system.

For example, if three interlock switches are connected to the monitoring unit, certain faults are detected only at the switch on the first-opened guard and the switch on the last-closed guard. Faults are only detected at these times because any switching between the first opening and last closing does not change the state of the monitoring unit input circuits. Therefore, in some applications it is necessary to use one monitoring device per switch.

Most of the examples in this publication show an interlock switch and an emergency stop switch that are combined in the circuit. When a monitoring safety relay (for example, a GSR module) is used for fault detection, it is important to note the following:

- All safety-critical single faults, except for certain faults over the contact set at the E-stop, are detected at the next opening of the guard.
- All safety-critical single faults, except for certain faults over the contact set at the interlock switch, are detected at the next operation of the E-stop.
- Because the E-stop device is operated infrequently, we recommend that you check its function (with the guard closed) regularly, at the start of your shift or daily, to enable the safety monitoring relay to detect single faults. If the guard is rarely opened, the interlock switch must be checked in a similar manner.

**Note 5**

 This symbol indicates that the associated component or device features direct opening (positive opening) operation. In the event of a fault, welded contacts are forced open by the motion of the safety guard or E-stop device.

 This symbol denotes mechanically linked contacts; if one contact welds closed, all other dependent (auxiliary) contacts remain in position (that is, they cannot change state).

## General Safety Information

**IMPORTANT** The examples in this section are for advanced users and assumes that you are trained and experienced in safety system requirements. Contact your local Rockwell Automation sales office or Allen-Bradley distributor for more information about our safety risk assessment services.



**ATTENTION:**

Perform a risk assessment to make sure that all tasks and hazard combinations are identified and addressed. The risk assessment requires additional circuitry to reduce the risk to a tolerable level. Safety distance calculations are an important consideration in safety circuits, but is not part of the scope of this document.

## Additional Resources

These documents contain additional information concerning related products from Rockwell Automation.

Resource	Description
GuardShield™ Micro 400 Safety Light Curtains User Manual, publication <a href="#">445L-UM003</a>	Provides an explanation of safety distance calculations.
Industrial Automation Wiring and Grounding Guidelines, publication <a href="#">1770-4.1</a>	Provides general guidelines for installing a Rockwell Automation® industrial system.
Product Certifications website, <a href="http://www.ab.com">http://www.ab.com</a>	Provides declarations of conformity, certificates, and other certification details.

You can view or download publications at <http://www.rockwellautomation.com/literature/>.

## SI Safety Relay with E-stop to PowerFlex 525 Drive

### Circuit Components

- E-stop
- Single input (SI) safety relay
- PowerFlex® 525 drive

### Circuit Status

The SI safety relay logic is set to MM (monitored manual reset). The E-stop is released. The SI safety outputs (13/14 and 23/24) are off. The PowerFlex 525 drive is powered, but disabled. The motor is off.

### Operating Principle

**STARTING:** Press the Reset button to turn on the SI safety outputs. The drive is enabled and power is applied to the Start and Stop buttons. Press the Start button to start the motor.

**STOPPING:** Press the Stop button to stop the motor for production stops. Press the E-stop to initiate a safety stop. The motor coasts to a stop.

### Fault Detection

Upon successful completion of internal checks by the SI safety relay and PowerFlex 525 drive, the drive awaits the closure of the safety outputs. If the SI safety relay fails, the drive does not energize the motor, and non-operation of the motor indicates the fault. The SI safety relay generates test pulses through the E-stop circuits to detect cross channel shorts and shorts to power and ground. The drive detects some faults in the safe-circuit of the drive and the drive executes a Safe Torque Off stop. The safety system does not detect a short circuit from S1 to S2.

### Ratings

The E-stop initiates a safety function that meets the safety performance requirements of SIL CL 2 per IEC 62061:2005 and has a Category 3 structure that can be used in systems that require Performance Levels up to PLd per ISO 13849-1: 2006. The circuit executes a Safe Torque Off stop.

**Figure 1 - SI Safety Relay with E-stop to PowerFlex 525 Drive**

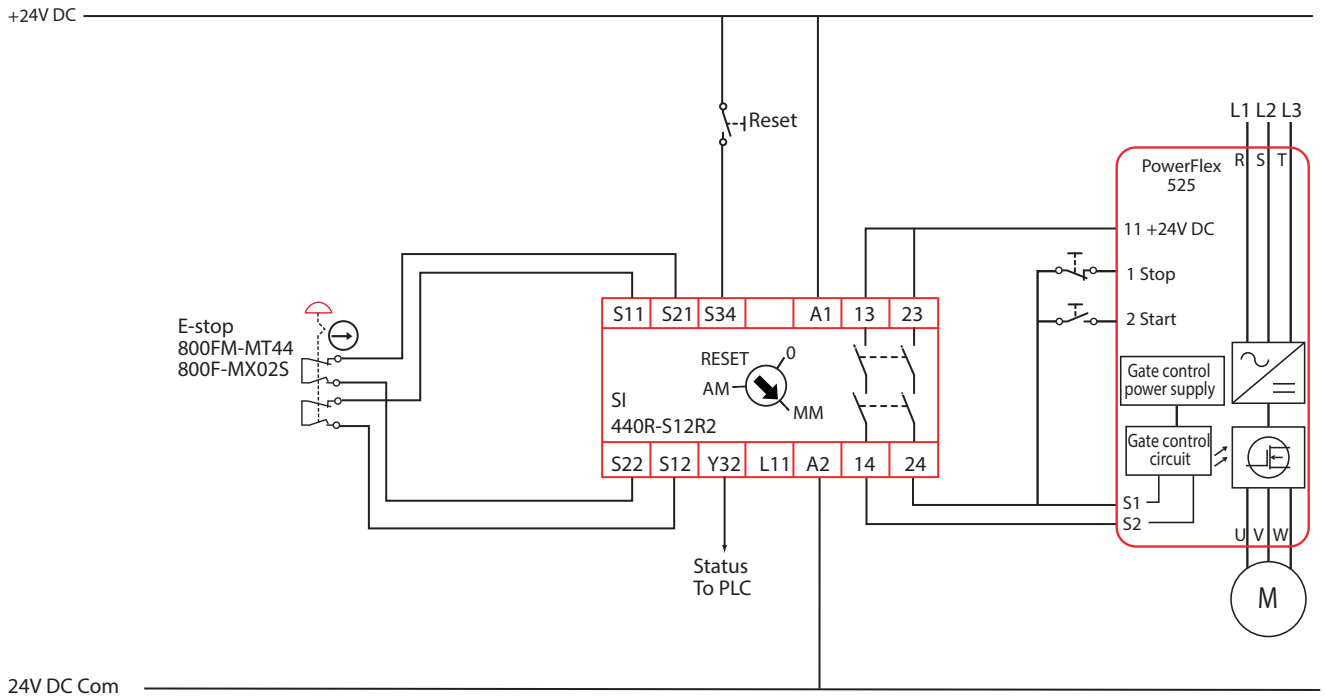

## SI Safety Relay with MAB Guard Locking to PowerFlex 525 Drive

### Circuit Components

- Multifunctional Access Box (MAB)
- SI safety relay
- PowerFlex 525 drive

### Circuit Status

The SI safety relay logic is set to MM (monitored manual reset). The MAB is closed and locked. The SI safety outputs (13/14 and 23/24) are off. The PowerFlex 525 drive is powered but disabled. The motor is off.

### Operating Principle

**STARTING:** Press the Reset button to turn on the SI safety outputs. The drive is enabled and power is applied to the Start and Stop buttons. Press the Start button to start the motor.

**STOPPING:** Press the Stop button to stop the motor for production stops. Press the E-stop to initiate a safety stop; the motor coasts to a stop.

**GATE ACCESS:** Rotate the Unlock Request button to apply power to unlock the gate. This action immediately opens the safety outputs of the MAB, which in turn causes the safety outputs of the SI to turn OFF. Then, the PowerFlex 525 drive safety inputs turn OFF and the motor coasts to a stop. The stopping time of the machine must be less than the time from when the operator presses the Unlock Request to when the operator can reach the hazard.

### Fault Detection

Upon successful completion of internal checks by the MAB, SI safety relay, and PowerFlex 525 drive, the drive awaits the closure of the safety outputs. If the SI safety relay faults, the drive does not energize the motor, and non-operation of the motor indicates the fault. The MAB generates test pulses through its output signals to detect cross-channel shorts and shorts to power and ground. The MAB Fault Reset switch clears faults within the MAB. The drive detects a fault in the safe-circuit of the drive and the drive executes a Safe Torque Off stop. The safety system does not detect a short circuit from S1 to S2.

### Ratings

The E-stop initiates a safety function that meets the safety performance requirements of SIL CL 2 per IEC 62061:2005 and has a Category 3 structure that can be used in systems that require Performance Levels up to PLd per ISO 13849-1:2006. The circuit executes a Safe Torque Off stop.



**Figure 2 - SI Safety Relay with MAB Guard Locking to PowerFlex 525 Drive**

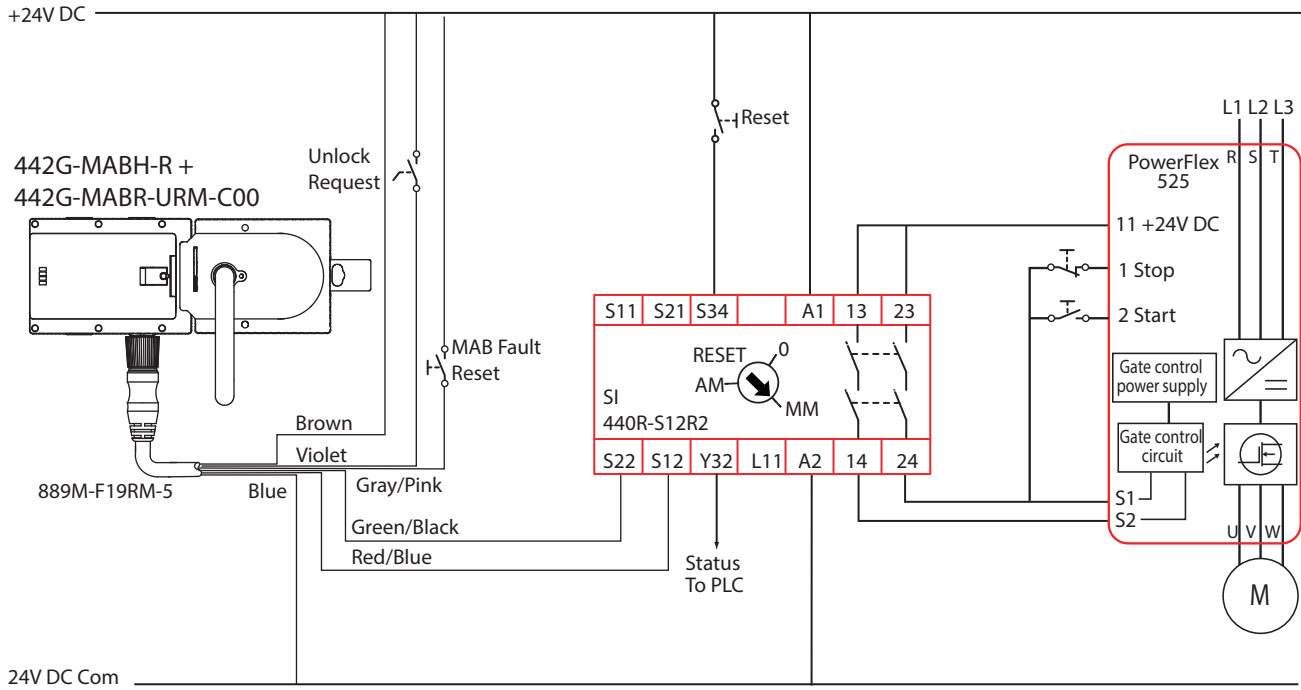

## SI Safety Relay to FLEX I/O

### Circuit Components

- Trojan™ T15 GD2 tongue interlock switch
- Bulletin 800F push button
- SI safety relay
- FLEX™ I/O module

### Circuit Status

The safety gate is closed. The outputs of the SI safety relay are open and the machine actuators are off. Control Relay CR1 is de-energized and the 11/12 contact is closed.

### Operating Principle

The SI safety relay is chosen for this application because its thermal (non-switching) current carrying capacity is 6 A in one circuit. During the manufacturing process, the FLEX output module switches the machine actuators. The safety system enables the machine functions by providing power to the FLEX output module. One of the FLEX outputs must drive an electromechanical device (CR1) whose normally closed contact is in the monitoring loop of the safety relay. The machine logic must energize this output while the machine is running, as it is used by the SI safety relay to confirm that power is removed from the output module, before restarting.

**STARTING:** Press the Reset button to energize the output contacts 13/14 of the SI safety relay. This action connects the 24V supply to terminal C34 of catalog number 1974-OB16 FLEX output module and also sends a signal to the A3 terminal of the catalog number 1794-IB16 input module. The logic system is informed that the gate is closed and the machine is ready to run. Press the Start button to start the machine process.

**STOPPING:** Press the Stop button to stop the machine. Then, open the gate to access the machine. While the gate is open, the machine actuators cannot operate because power is removed from the output module. If the gate is inadvertently opened while the machine is running, power is removed from output module and the machine actuators are de-energized.

### Fault Detection

Upon successful completion of internal checks on power-up, the SI checks the input circuits. With the gates closed, the SI safety relay checks the dual circuits and then waits for the reset signal. A fault, a short from 24V to terminal 14 of the SI safety relay, can lead to the loss of the safety function. When the SI safety relay and FLEX system are mounted in the same cabinet with proper validation, this fault can be excluded. If not mounted in the same cabinet, a signal from the output (A0) should be fed back into the input module (A2). The logic can perform a comparison of input A2 and A3, and turn off the machine if these signals are not in agreement. If CR1 is not de-energized when the gate is closed, the SI safety relay does not close its outputs.

### Ratings

The Trojan T15-GD2 gate interlock initiates a safety function that meets the safety performance requirements of SIL CL 2 per IEC 62061:2005 and has a Category 3 structure that can be used in systems that require Performance Levels up to PLD per ISO 13849-1:2006. This circuit executes a Stop Category 0.

**Figure 3 - SI Safety Relay to FLEX I/O**

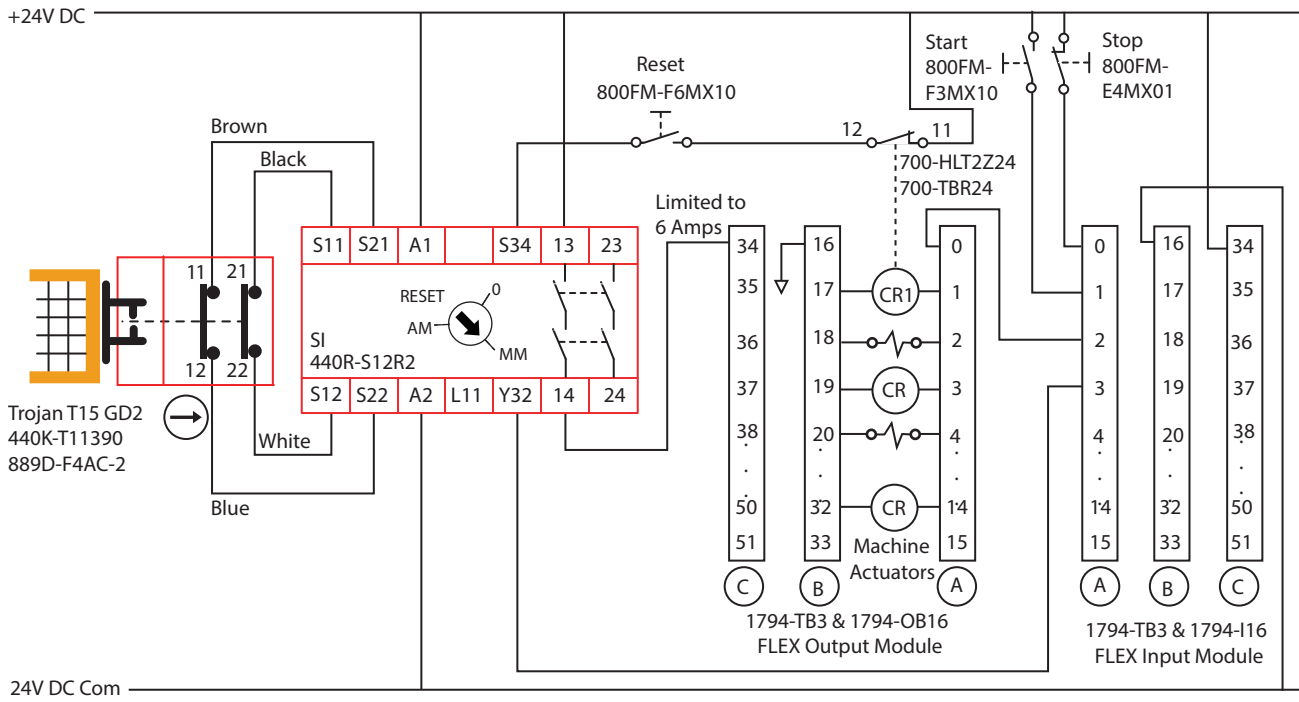

## Expansion Modules with Immediate and Delayed Outputs

### Circuit Components

- Bulletin 800F E-stops
- SI, expansion module (EM), expansion module time-delayed (EMD) safety relays
- Bulletin 100S contactor
- Bulletin 700S safety control relay

### Circuit Status

The E-stops are reset. The safety outputs of the SI, EM, and EMD safety relays are de-energized. All contactors are off. The EMD Range setting is 2 (10-second OFF Delay) and the Time setting is 2 (20%), therefore the time delay is 2 seconds. The reset and monitoring circuit are connected to S34 for monitored manual reset.

### Operating Principle

Additional outputs are added to the SI safety relay (CI, DI, or DIS) by the EM safety relay (immediate outputs) and the EMD safety relay (delayed outputs). A single wire, safety-rated signal from terminal L11 of the SI communicates the output status to L12 of the EM and EMD safety relays.

**STARTING:** Press and release the Reset button to energize the outputs of the SI, EM, and EMD safety relays. K1...K10 safety contactors or safety control relays energize to control the hazardous portion of the machine.

**STOPPING:** When an E-stop is pressed, the safety outputs of the SI and EM safety relays turn off immediately and de-energize K1...K6. Two seconds later, the safety outputs of the EMD safety relay turn off and de-energize K7...K10.

### Fault Detection

Upon power-up, the SI, EM, and EMD safety relays perform internal checks. Then, the SI safety relay looks for dual signals from the E-stop circuit. The SI safety relay detects a cross fault on the E-stop circuit. With the E-stop signals made, closing the Reset button places a voltage to the S34 terminal. The external devices (K1...K10) are checked to confirm that they are off. A fault in K1...K10 causes their normally closed contacts to remain open, and this fault prevents the SI safety relay from turning on outputs 13/14 and 23/24.

### Ratings

The series connection of the Bulletin 800F E-stop buttons initiates a safety function that meets the safety performance requirements of SIL CL 2 per IEC 62061:2005 and has a Category 3 structure that can be used in systems that require Performance Levels up to PLd per ISO 13849-1:2006. The Category 3 rating requires the redundant usage of K1...K10 to de-energize the machine actuators, and the safety system must monitor the contactors. This circuit executes a Stop Category 0.

**Figure 4 - Expansion Modules with Immediate and Delayed Outputs**

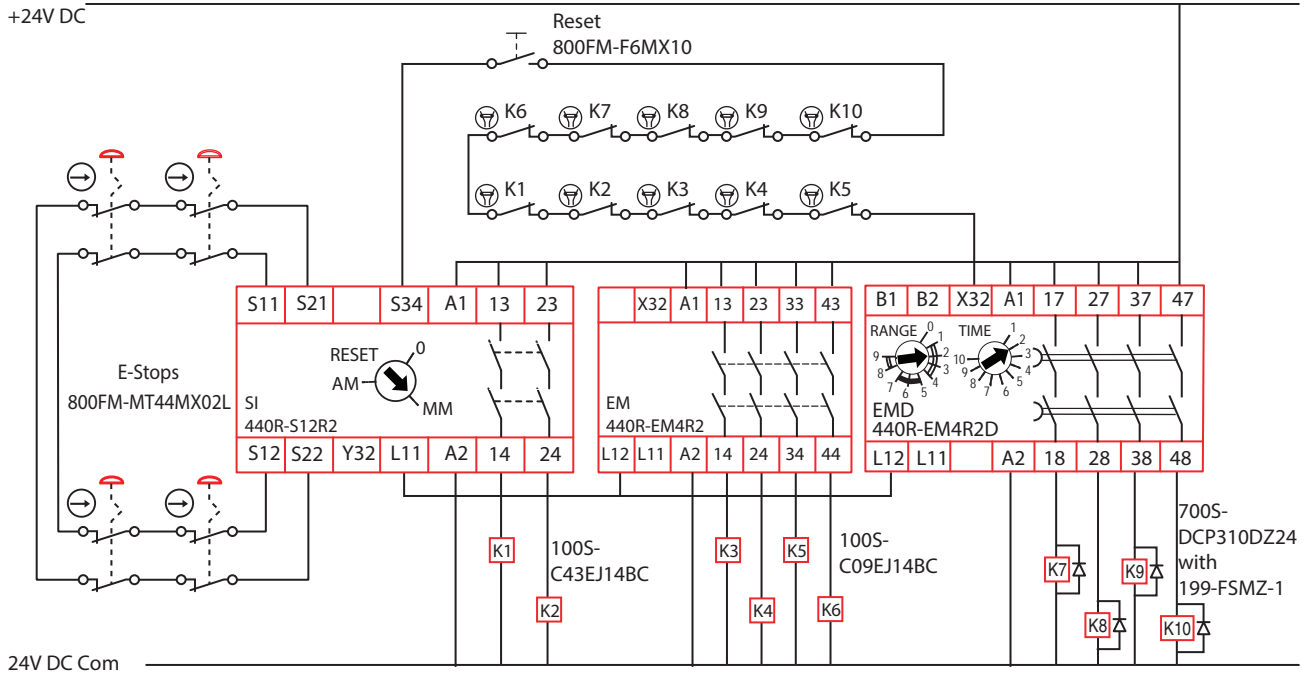

## Safety Motion — Delayed Braking

### Circuit Components

- Bulletin 800F E-stops
- SI and EMD safety relays
- Kinetix® GuardMotion™ with Resistor Braking Module (RBM)

### Circuit Status

The E-stop is reset. The outputs of the safety relay are open, and the motor is off. The EMD Range switch is set to 1 (1-second OFF Delay) and the Time is set to 10 (100%), therefore the OFF Delay time is 1 second.

### Operating Principle

**STARTING:** Press and release the Reset button to energize the outputs of the SI safety relay. This action energizes the feedback relays in the Kinetix. The L11 signal from the SI safety relay to the EMD safety relay instructs the EMD safety relay to close its safety outputs. This action energizes the Bulletin 100S contactor in the resistor braking module. The motor is now connected to the drive. When the Kinetix drive is enabled, an internal signal is sent back to its controller (not shown) to inform it that the drive is enabled. The controller then controls the motor.

**STOPPING:** When the E-stop is pressed, the immediate outputs of the SI open and disable the drive. The motor begins to execute a stop. The L11 signal from the SI safety relay to the EMD safety relay turns off and the EMD safety relay begins its timing cycle. After the time delay of the EMD safety relay expires, the delayed outputs open and drop out the Bulletin 100S contactor in the RBM. This action disconnects the motor from the drive and engages the braking resistors, which rapidly stop the motor.

### Fault Detection

Upon power-up, the Kinetix drive and SI and EMD safety relays perform internal checks. The SI safety relay then looks for dual signals from the E-stop. The E-stop has self-monitoring contacts, which open if the contact block falls off the control panel. With the E-stop signals made, the SI safety relay checks the S34 monitoring circuit when the Reset button is pressed. If these checks are OK, the output energizes. If the delayed outputs of the EMD safety relay fault to the ON state, the SI safety relay does not start the motor. The S34 monitoring circuit detects the fault on the next attempt to restart because K1 remains energized. If the drive faults to an ON state, the motor stops because K1 disconnects it. The S34 monitoring circuit detects this fault on the next attempt to restart because the Kinetix feedback circuit remains off. If K1 gets stuck or welded closed, the drive stops the motor and the S34 monitoring circuit of the SI safety relay detects the fault on the next attempt to restart.

### Ratings

The Bulletin 800F E-stop initiates a safety function that meets the safety performance requirements of SIL CL 3 per IEC 62061:2005 and has a Category 4 structure that can be used in systems that require Performance Levels up to PLe per ISO 13849-1:2006. This circuit executes a Stop Category 1.

**Figure 5 - Safety Motion — Delayed Braking**

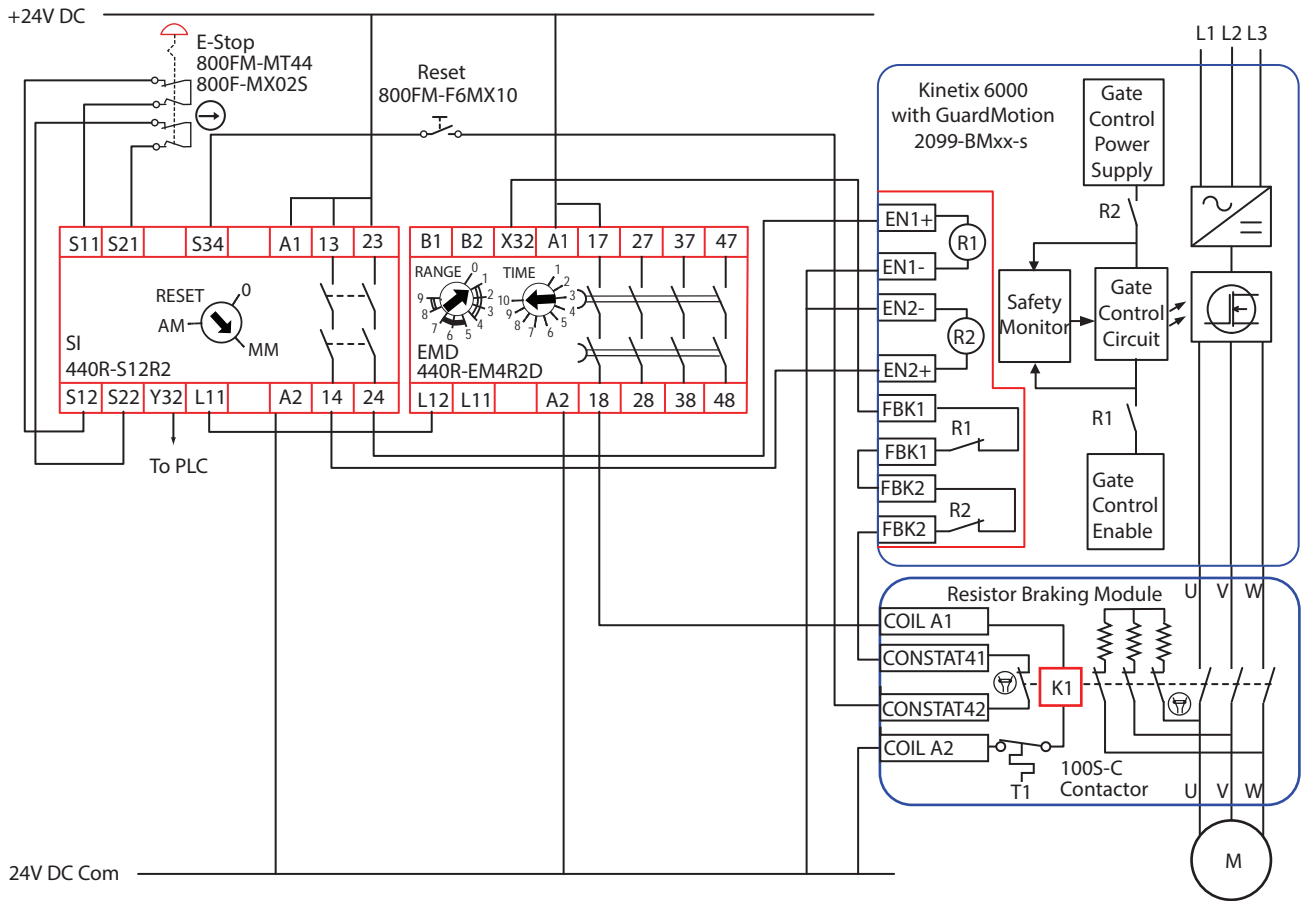

## Light Curtain with Immediate and Delayed Outputs

### Circuit Components

- Safe 4 light curtain
- SI and EMD safety relays
- Bulletin 100S contactor
- Bulletin 700S safety control relay

### Circuit Status

The light curtain is clear. The safety outputs of the SI and EMD are de-energized. All contactors are off. The EMD Range setting is 2 (10-second OFF Delay) and the Time setting is 2 (20%), therefore the time delay is 2 seconds. The reset and monitoring circuit are connected to S34 for monitored manual reset.

### Operating Principle

Additional outputs are added to the SI safety relay by the EMD (expansion module with delayed outputs) safety relay. A single wire safety rated signal from terminal L11 of the SI communicates the output status to L12 of the EMD safety relay.

**STARTING:** Press and release the Reset button to energize the outputs of the SI and EMD safety relay. K1...K6 safety contactors or safety control relays energize to control the hazardous portion of the machine.

**STOPPING:** When the light curtain is interrupted, the safety outputs of the SI safety relay turn off immediately and de-energize K1...K2. Two seconds later, the safety outputs of the EMD safety relay turn off and de-energize K3...K6.

### Fault Detection

Upon power-up, the SI and EMD safety relays perform internal checks. The SI safety relay then looks for dual signals from the light curtain. The light curtain detects a cross fault on the light curtain. With the light curtain signals made, closing the Reset button places a voltage to the S34 terminal. The external devices (K1...K6) are checked to confirm that they are off. A fault in K1...K6 causes their normally closed contacts to remain open, and the SI safety relay detects this fault.

### Ratings

The light curtain initiates a safety function that meets the safety performance requirements of SIL CL 3 per IEC 62061:2005 and has a Category 4 structure that can be used in systems that require Performance Levels up to PLc per ISO 13849-1:2006. The Category 4 rating requires the redundant usage of K1...K6 to de-energize the machine actuators, and the safety system must monitor the contactors. This circuit executes a Stop Category 0.



**Figure 6 - Light Curtain with Immediate and Delayed Outputs**

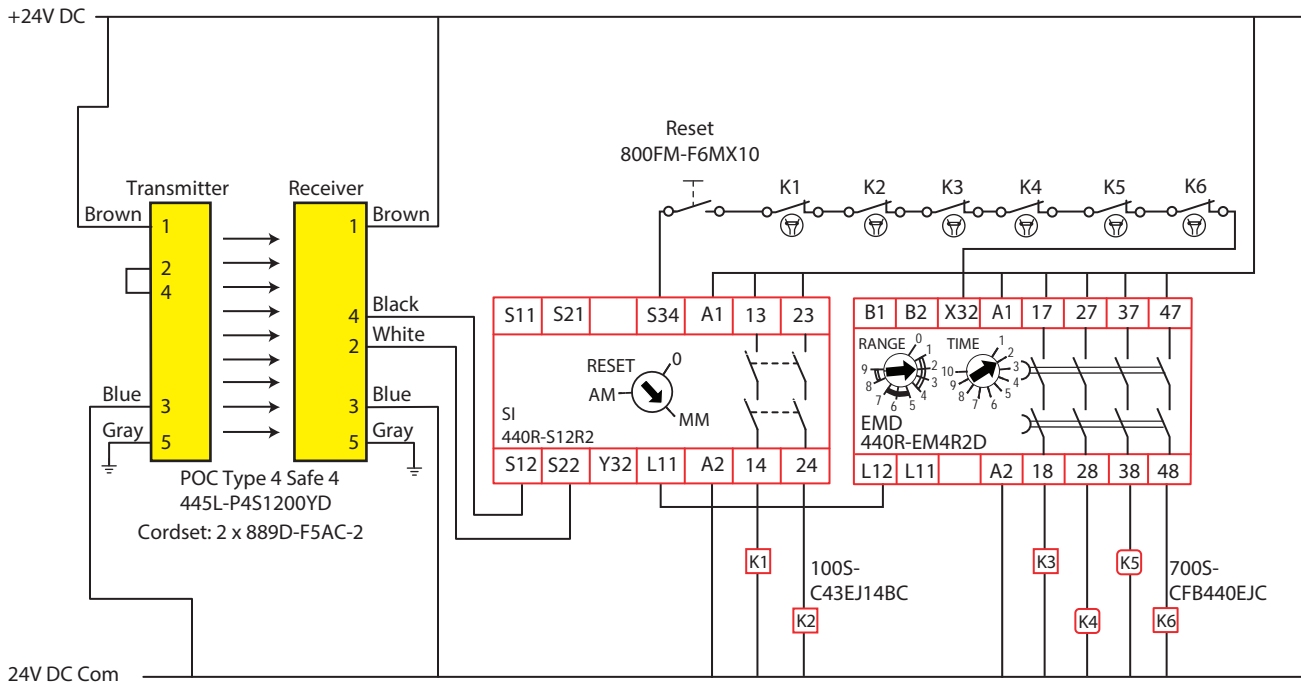

## Global E-stop, Cascaded Safety Functions

### Circuit Components

- Bulletin 800F E-stops
- Trojan T15 tongue interlock switch
- Bulletin 440F MatGuard™ safety mat
- SI, dual-input (DI), dual-input solid-state output (DIS) safety relays
- Bulletin 100S contactor
- Bulletin 700S safety control relay

### Circuit Status

The E-stops are reset. The safety gate is closed. The safety mat is unoccupied. The outputs of all three safety relays are off. K1...K6 are ready to be energized. The SI is set for monitored manual reset. The DI safety relay has logic set to 4 [(IN1 AND IN2) AND L12] with monitored manual reset because the safety gate provides full body access. The DIS safety relay has logic set to 4 [(IN1AND IN2) AND L12] with monitored manual reset. Safety mat applications require Logic setting with IN1 AND IN2.

### Operating Principle

The SI safety relay provides a global E-stop function. The DI and DIS safety relays are cascaded from the SI safety relay.

**STARTING:** Press the Reset button for the SI safety relay to energize its outputs. Then, press the Start button to energize K1 and K2 and send the L11 link signal to the DI safety relay that enables the DI safety relay. Press the Reset button to energize the DI safety relay and send a L11 link signal to the DIS safety relay. Press the Reset button to energize the outputs of the DIS safety relay. Press the respective Start buttons to energize the contactors K3, K4, K5, and K6.

**STOPPING:** Press the E-stop of the SI safety relay to shut down all three relays. Open the interlocked gate or press the E-stop of the DI safety relay to turn off the outputs of both the DI and DIS safety relays, while the SI safety relay is unaffected. Press the E-stop or step on the safety mat of the DIS safety relay to turn off the outputs of the DIS safety relay only.

### Fault Detection

Upon successful completion of internal checks on power-up, the SI, DI, and DIS safety relays check their input circuits. Shorts from the inputs to power, ground, or other inputs are detected immediately and prevents energization or de-energizes the respective outputs. If one of the contactors (K1...K6) is stuck in an actuated state, the respective control prevents startup because the S34 feedback loop remains open. For fault detection purposes, all GSR modules that are used in safety mat applications must be configured for monitored manual reset.

### Ratings

The E-stop devices and the two Trojan interlocks initiate safety functions that meet the safety performance requirements of SIL CL 3 per IEC 62061:2005 and have Category 4 structures that can be used in systems that require Performance Levels up to PLe per ISO 13849-1:2006.

The safety mat initiates a safety function that meets the safety performance requirements of SIL CL 2 per IEC 62061:2005 and has a Category 3 structure that can be used in systems that require Performance Levels up to PLd per ISO 13849-1:2006. This circuit executes a Stop Category 0.

**Figure 7 - Global E-stop, Cascaded Safety Functions**

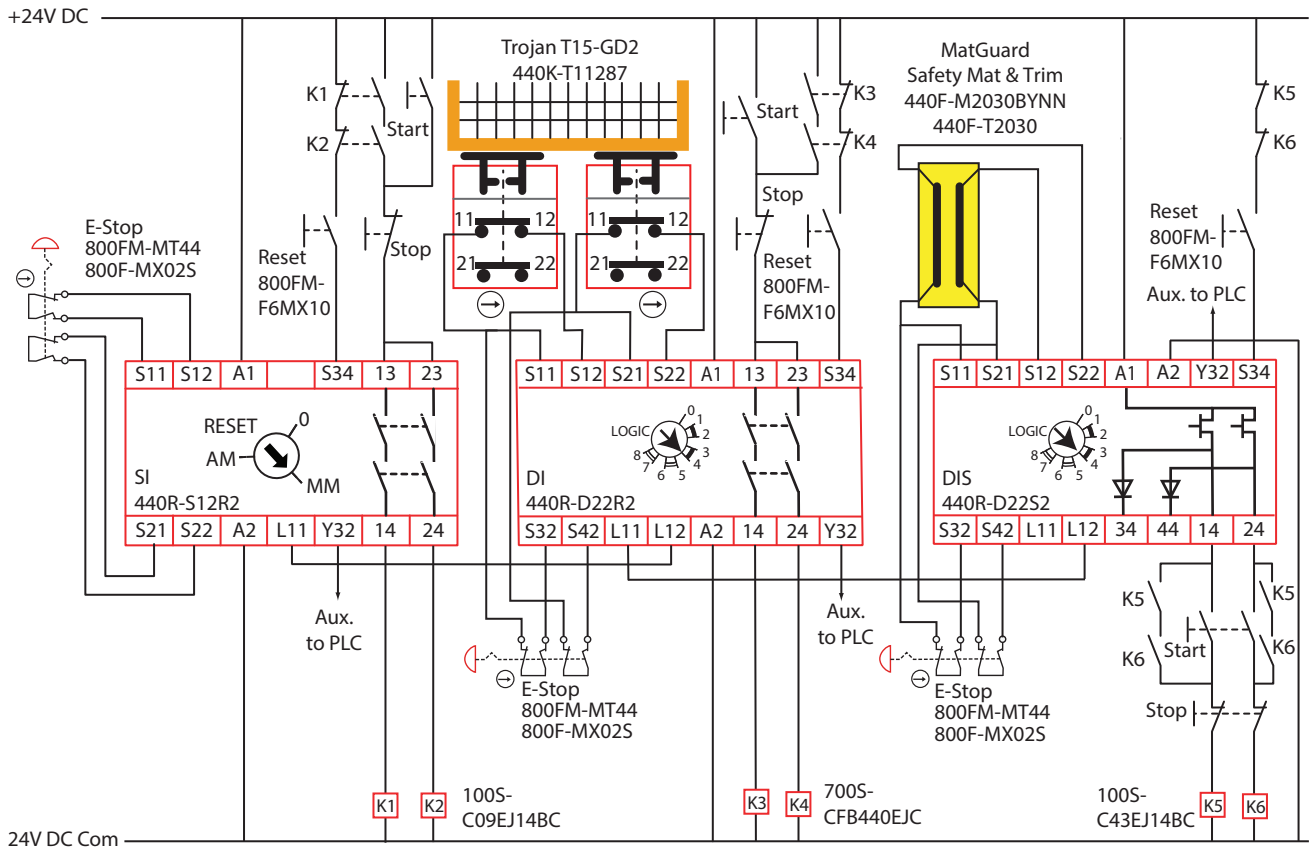

## GuardShield Light Curtain and Bulletin 800Z Zero-Force Touch Buttons

### Circuit Components

- GuardShield™ light curtain
- Bulletin 800Z Zero-Force Touch Buttons™
- SI and MSR35H safety relay
- Bulletin 100S contactor

### Circuit Status

The hands of the operator are not on the two Bulletin 800Z Zero-Force Touch Buttons. The outputs of the MSR35H are off. The light curtain is configured with the factory default settings (Guard only mode) and is unobstructed. The outputs of the SI safety relay are off. The motor is off and ready to run.

The light curtain helps protect one portion of the machine. An operator, using two-hand control accesses another portion of the machine and has full view of their area.

### Operating Principle

**STARTING:** Press the Reset button to energize the output of the SI safety relay. The operator places both hands on the Bulletin 800Z Zero-Force Touch Buttons simultaneously (within 0.5 seconds). The outputs of the MSR35H (terminals 14 and 24) energize the Bulletin100S contactors, which start the motor.

**STOPPING:** Removal of one or both hands from the Bulletin 800Z touch buttons causes the outputs of the MSR35H safety relay to turn off, which drops out K1 and K2 and stops the motor. Obstructing the light curtain de-energizes the safety outputs of the SI safety relay, which in turn drops out K1 and K2 and turns off the motor. Clearing the light curtain does not restart the motor, even if the operator has their hands on the palm buttons. The Reset button must be pressed after the light curtain is cleared.

### Fault Detection

Upon power-up, the Bulletin 800Z, GuardShield light curtain, MSR35H safety relay, and SI safety relay perform internal checks. After passing internal checks, the MSR35H safety relay waits for a change of state of its inputs. The MSR35H safety relay detects faults (opens and shorts) at the inputs and prevent the outputs from being energized. The GuardShield light curtain also performs checks on its Output Signal Switching Device (OSSD) output signals for cross faults, shorts, and opens. The SI safety relay looks for dual signals at its inputs. It then checks the status of the contactors. If one contactor fails in the actuated state, the other contactor stops the motor. The SI safety relay detects if one of the contactors are stuck in the energized position, and prevents restart.

### Ratings

The GuardShield light curtain provides a safety function that meets the safety performance requirements of SIL CL 3 per IEC 62061:2005 and has a Category 4 structure that can be used in systems that require Performance Levels up to PLe per ISO 13849-1:2006. This circuit executes a Stop Category 0.

The safety function of the two-hand control meets Type IIIC of ISO 13851.



## SI/DIS Safety Relays, SensaGuard Interlock, E-stops, and PowerFlex 525 Drive with Contactor

### Circuit Components

- SensaGuard™ integrated latch interlocks
- Bulletin 800F E-stop
- SI and DIS safety relays
- Bulletin 100S contactor
- PowerFlex 525 drive

### Circuit Status

The DIS safety relay logic is set to 4: [(IN1 AND IN2) AND L12] with monitored reset. The SI is set for automatic reset. The SensaGuard integrated latch interlocks are connected in series to the SI. The two E-stops are connected to inputs 1 (S12 and S22) and 2 (S32 and S42) of the DIS. The three gates, monitored by the SensaGuard integrated latch interlocks, are closed and safety outputs of the SI (L11, 13/14 and 23/24) are ON. Both E-stops are released. The DIS safety outputs (14, 24, 34 and 44) are off and await a reset signal. The PowerFlex 525 drive is powered but disabled. Contactor K1 is de-energized. The motor is off.

### Operating Principle

**STARTING:** Press the Reset button to turn on the DIS safety outputs. K1 is energized, which enables the drive, and also applies power to the Start and Stop buttons. Press the Start buttons to start the motor.

**STOPPING:** Press the Stop button to stop the motor for production stops. Press either E-stop or open any safety gate to initiate a safety stop; the motor coasts to a stop.

### Fault Detection

Upon successful completion of internal checks by the SI safety relay, DIS safety relay, SensaGuard, and PowerFlex 525 drive, the drive awaits the closure of the safety outputs. If the DIS safety relay fails, the drive does not energize the motor, and non-operation of the motor indicates a fault. The DIS safety relay generates test pulses through the E-stop circuits to detect cross channel shorts and shorts to power and ground. The SensaGuard interlocks generate test pulses on their outputs to detect cross channel shorts and shorts to power and ground. The drive detects a fault in the safe-circuit of the drive and issues a safety stop. The DIS safety relay monitors the mechanically linked contacts of K1 to verify that the contactor is de-energized before resetting the safety system.

### Ratings

The SensaGuard integrated latch interlocks and the E-stop initiate safety functions that meet the safety performance requirements of SIL CL 3 per IEC 62061:2005 and a Category 4 structure that can be used in systems that require Performance Levels up to PLe per ISO 13849-1: 2006. The circuit executes a Stop Category 0.

**Figure 9 - SI/DIS Safety Relays, SensaGuard Interlock, E-stops, and PowerFlex 525 Drive with Contactor**

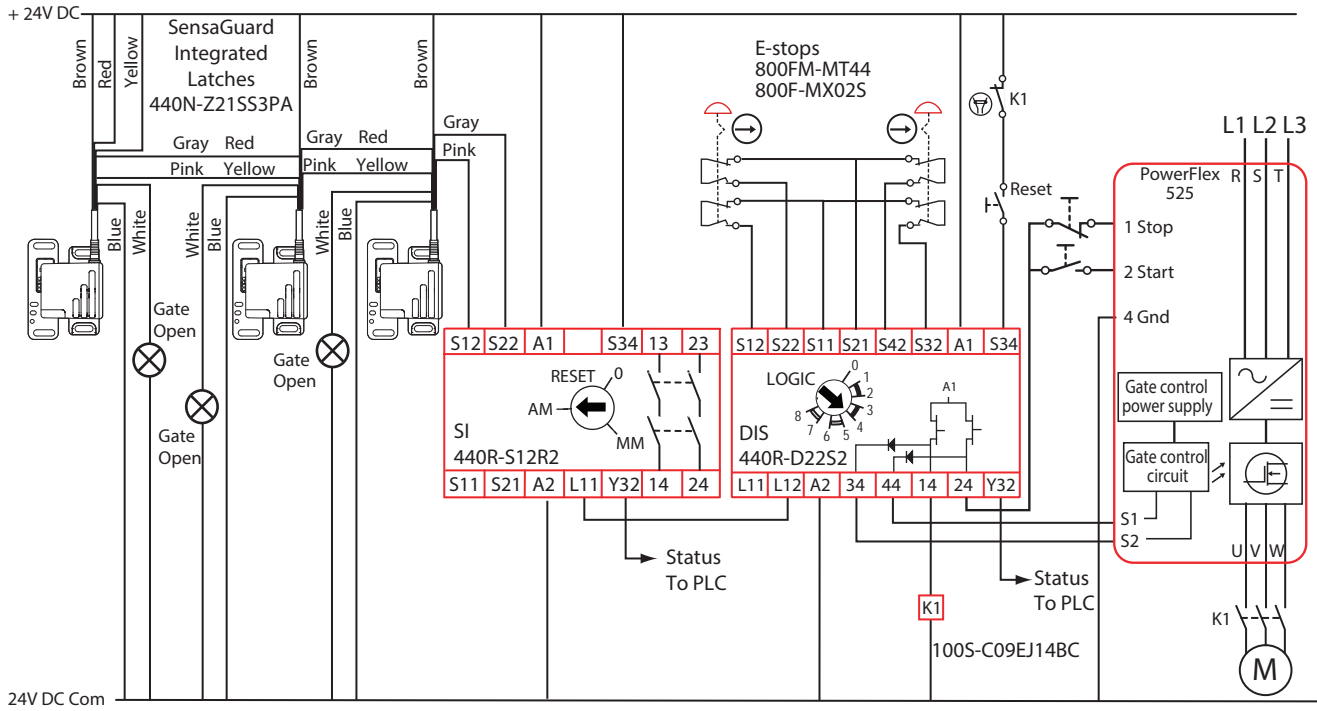

## Interlock Switch — Multiple Gate Access

### Circuit Components

- Trojan T15 and Elf GD2 tongue interlock switch
- Bulletin 800F E-stop
- Compatible input (CI) safety relay
- Bulletin 100S contactor

### Circuit Status

The circuit is shown with the safety gates closed and the E-stop released. The CI safety relay is de-energized. The motor is off. The monitoring circuit is connected to S34 for automatic reset of the CI safety relay.

### Operating Principle

This circuit shows how to connect the second channel of the interlock switches through a standard programmable logic controller (PLC) to get status information without auxiliary contacts in the interlock switch. The PLC program must monitor the safety relay and prevent the PLC from turning the output ON if the safety relay is not OFF.

**STARTING:** Channel 1 input (S11/S12) of the CI safety relay is satisfied. Using isolated relay contacts in its output module, the PLC closes the second safety channel (21/22 of the CI safety relay). The safety outputs of the CI safety relay close. Press the Start button to start the motor.

**STOPPING:** Opening any one of the safety gates or pressing the E-stop causes the motor to turn off. Closing the gate or releasing the E-stop does not cause the motor to start due to the start-stop interlocking circuit. To restart the motor, close the safety gate or release the E-stop. Then, press the Start button.

### Fault Detection

If the PLC fails with its output closed, the safety relay detects the difference between the safety gate and the PLC and stops the motor. The safety relay detects a single fault (open or short) across one of the interlocks and the motor is turned off. The motor remains off until the fault is corrected or power is cycled. If either contactor K1 or K2 sticks ON, the motor stops on command due to the other contactor, but the CI safety relay cannot be reset (which reveals the fault). A single fault that is detected on the CI safety relay input circuits results in the lockout of the system to a safe state (OFF) at the next operation of the safety gate or E-stop device. The safety system controls contactors K1 and K2. The machine control system and the safety system control contactor K2. This configuration increases the probability of performance of the safety function because the K1 contacts are less likely to weld due to the diversity of expected wear out times.

### Ratings

The Trojan T15 and ELF-GD2 safety gate interlocks and the Bulletin 800F E-stop initiate a safety function that meets the safety performance requirements of SIL CL 2 per IEC 62061:2005 and has a Category 3 structure that can be used in systems that require Performance Levels up to PLd per ISO 13849-1:2006. This circuit executes a Stop Category 0.



**Figure 10 - Interlock Switch — Multiple Gate Access**

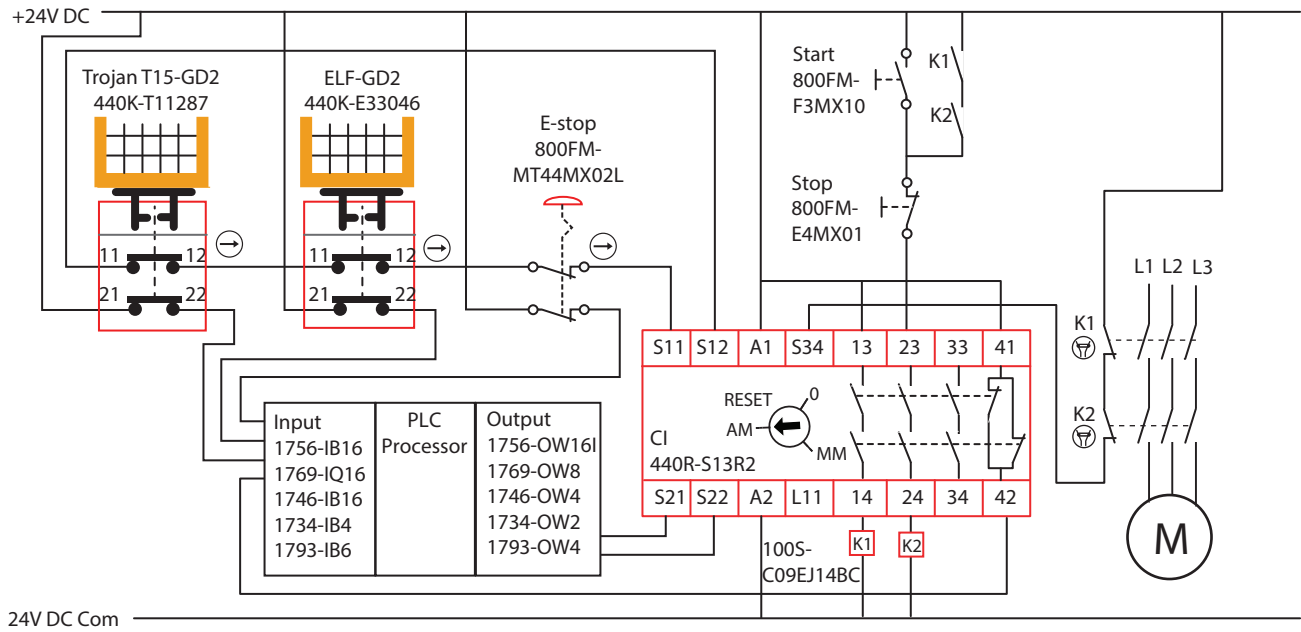

## SensaGuard Interlock Switches

### Circuit Components

- SensaGuard non-contact interlock switches
- CI safety relay
- Bulletin 800F push buttons
- Bulletin 100S contactor

### Circuit Status

The first and third gates are closed. The second gate is open. The CI safety relay S12 and S22 inputs are open due to the open gate, and therefore, the CI safety outputs are open. The machine control PLC has a 24V auxiliary signal at terminal I1 from the second gate because the gate is open. The first and third auxiliary signals are off, as their gates are closed. The PLC also has an auxiliary signal from the CI safety relay that indicates that the safety system is not ready. The motor is off.

### Operating Principle

**STARTING:** Closing the second gate satisfies the input of the CI safety relay. The CI safety relay verifies that both K1 and K2 contactors are off and energizes its safety outputs. Pressing the Start button starts the motor. The machine control system (for example, a PLC) can replace the Stop/Start circuit since the circuit is not part of the safety system.

**STOPPING:** Press the Stop button to turn off the motor, without affecting the status of the safety system. Opening any of the gates causes the safety system to stop the motor.

### Fault Detection

Upon successful completion of internal checks on power-up, the SensaGuard interlock switches check for 24V at pins 4 and 8. If the actuator is within range, the SensaGuard interlock switch activates its OSSD outputs. The OSSD outputs continuously check for short circuits to 24V, ground, and cross faults. Upon detection of a fault, the OSSD outputs turn off. The CI safety relay also performs internal checks on power-up. It then checks for input signals. If OK, the CI safety relay checks the K1/K2/S34 monitoring circuit to determine whether both contactors are off. If one of the contactors gets stuck on, the other contactor de-energizes the motor, and the CI safety relay detects the fault at the next attempt to start the motor. The contactors have mechanically linked auxiliary contacts to help verify fault detection of the contactors.

### Ratings

The safety performance of this circuit meets the requirements of SIL CL 3 per IEC 62061:2005 and has Category 4 structure and can be used in systems that require Performance Levels up to PLe per ISO 13849-1:2006. The SensaGuard interlocks are designed to meet Category 4 when connected in series. The CI safety relay is rated to Category 4. The design and connection of the contactors meets category 4. This circuit performs a Stop Category 0.

**Figure 11 - SensaGuard Interlock Switches**

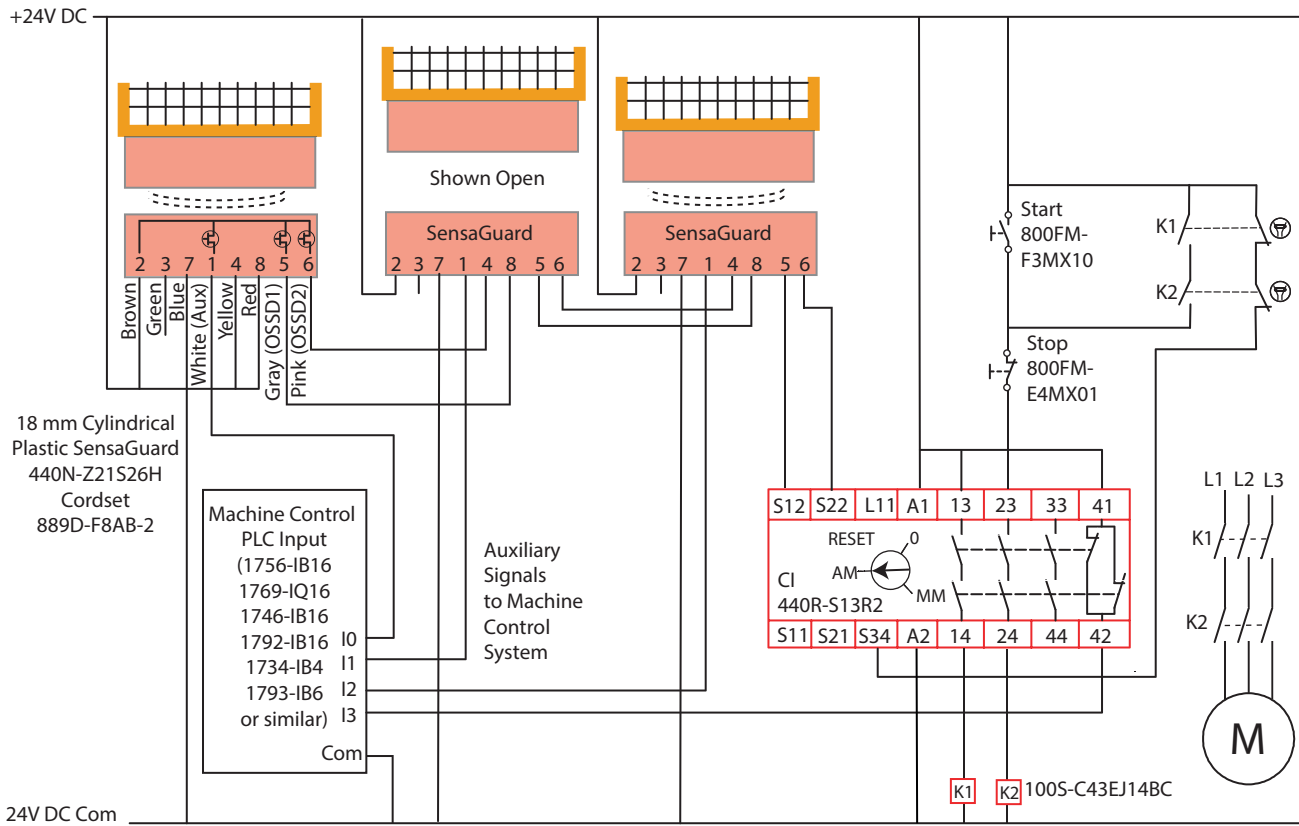

## Magnetically Coded Sensor

### Circuit Components

- MC2 magnetically coded non-contact interlock switch
- CI safety relay
- Bulletin 800F push buttons
- Bulletin 100S contactor

### Circuit Status

The first gate is open. The second and third gates are closed. The CI safety relay S12 and S22 inputs are open due to the open gate, and therefore, the CI safety outputs are open. The machine control PLC has a 24V auxiliary signal at terminal I0 from the first gate because the gate is open. The second and third auxiliary signals are off, as their gates are closed. The PLC also has an auxiliary signal from the CI safety relay that indicates that the safety system is not ready. The motor is off.

### Operating Principle

**STARTING:** Closing the first gate satisfies the input of the CI safety relay. The CI safety relay verifies that both K1 and K2 contactors are off and energizes its safety outputs. Pressing the Start button starts the motor. The machine control system (for example, a PLC) can replace the Stop/Start circuit since the circuit is not part of the safety system.

**STOPPING:** Press the Stop button to turn off the motor, without affecting the status of the safety system. Opening any of the gates causes the safety system to stop the motor.

### Fault Detection

Upon successful completion of internal checks on power-up, the CI safety relay checks for input signals. If OK, the CI safety relay checks the K1/K2/S34 monitoring circuit to determine whether both contactors are off. If one of the contactors gets stuck on, the other contactor de-energizes the motor, and the CI safety relay detects the fault at the next attempt to start the motor. The contactors have mechanically linked auxiliary contacts to help with fault detection of the contactors.

### Ratings

This safety performance of this circuit meets the requirements of SIL CL 2 per IEC 62061:2005 and has Category 3 structure and can be used in systems that require Performance Levels up to PLd per ISO 13849-1:2006. This circuit performs a Stop Category 0.

**Figure 12 - Magnetically Coded Sensor**

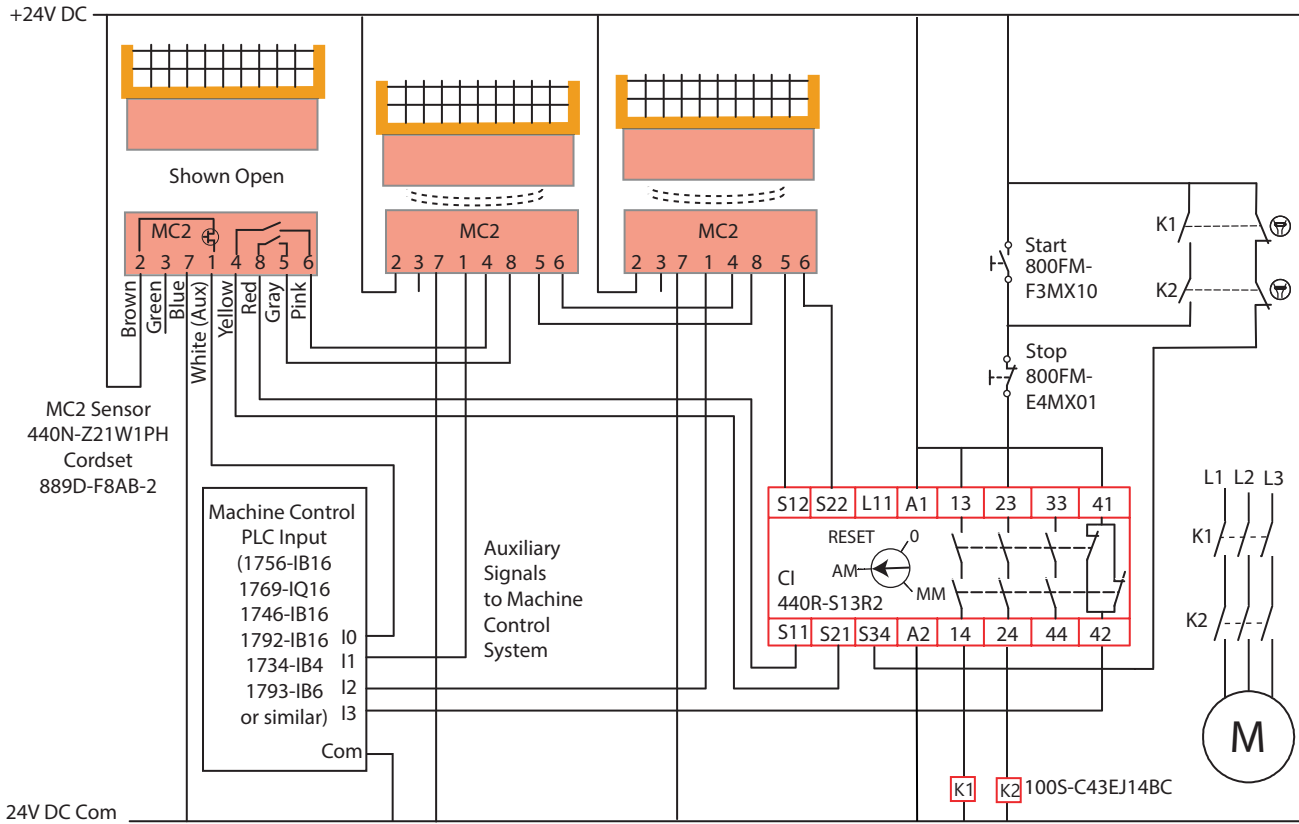

## Stainless Steel Ferrogard GD2 Non-contact Interlock Switch

### Circuit Components

- Ferrogard™ GD2 non-contact interlock switch
- CI safety relay
- Bulletin 800F push buttons
- Bulletin 100S contactor

### Circuit Status

The first gate is open. The second and third gates are closed. The CI safety relay S12 and S22 inputs are open due to the open gate, and therefore, the CI safety outputs are open. The machine control PLC has a 24V auxiliary signal at terminal I0 from the first gate because the gate is open. The second and third auxiliary signals are off, as their gates are closed. The PLC also has an auxiliary signal from the CI safety relay that indicates that the safety system is not ready. The motor is off.

### Operating Principle

**STARTING:** Closing the first gate satisfies the input of the CI safety relay. The CI safety relay verifies that both K1 and K2 contactors are off and energizes its safety outputs. Pressing the Start button starts the motor. The machine control system (for example, a PLC) can replace the Stop/Start circuit since the circuit is not part of the safety system.

**STOPPING:** Press the Stop button to turn off the motor, without affecting the status of the safety system. Opening any of the gates causes the safety system to stop the motor.

### Fault Detection

Upon successful completion of internal checks on power-up, the CI safety relay checks for input signals. If OK, the CI safety relay checks the K1/K2/S34 monitoring circuit to determine whether both contactors are off. If one of the contactors gets stuck on, the other contactor de-energizes the motor, and the CI safety relay detects the fault at the next attempt to start the motor. The contactors have mechanically linked auxiliary contacts to help with fault detection of the contactors.

### Ratings

This safety performance of this circuit meets the requirements of SIL CL 2 per IEC 62061:2005 and has Category 3 structure and can be used in systems that require Performance Levels up to PLd per ISO 13849-1:2006. This circuit performs a Stop Category 0.

**Figure 13 - Stainless Steel Ferrogard GD2 Non-contact Interlock Switch**

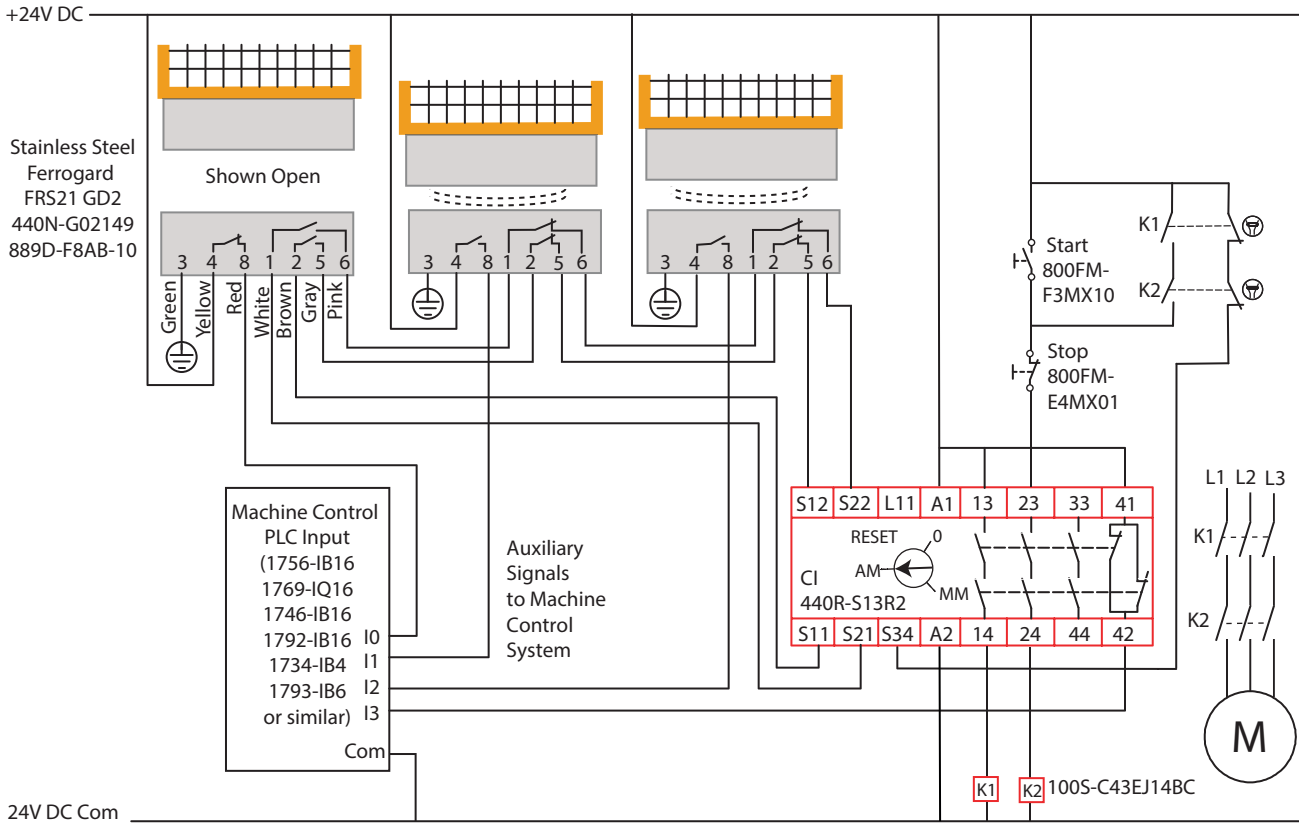

## Light Curtain — Point of Operation Control

### Circuit Components

- GuardShield light curtain
- DI safety relay
- Bulletin 800F push buttons
- Bulletin 100S contactor

### Circuit Status

The light curtain is clear and the motor is ready to run. The DI safety relay is set for Logic 5 (L12 or IN1 or IN2 with Automatic Reset).

### Operating Principle

**STARTING:** Press the Start button to energize contactors K2. The motor starts with the two normally open contacts of K1 and K2 holding the circuit energized.

**STOPPING:** Obstructing the light curtain de-energizes the safety outputs of the DI safety relay which in turn drops out K1 and K2. The contactors disconnect the motor from its power source, and the motor coasts to a stop. Clearing the obstruction in the light curtain does not cause the motor to start.

### Fault Detection

Upon successful completion of internal checks on power-up, the GuardShield light curtain energizes its outputs with no objects present. The successful completion of internal checks, the DI safety relay checks the signals from the light curtain. If OK, the DI safety relay then checks the status of the K1 and K2 contactors. If either K1 or K2 fails in the actuated state, the other contactor disconnects the motor. The DI safety relay detects the faulted contactor and does not allow the motor to restart until the fault is corrected. The safety system controls contactor K1. The machine control system and the safety system control contactor K2.

### Ratings

The GuardShield light curtain initiates a safety function that meets the safety performance requirements of SIL CL 3 per IEC 62061:2005 and has a Category 4 structure that can be used in systems that require Performance Levels up to PLe per ISO 13849-1:2006. This circuit executes a Stop Category 0.



**Figure 14 - Light Curtain — Point of Operation Control**

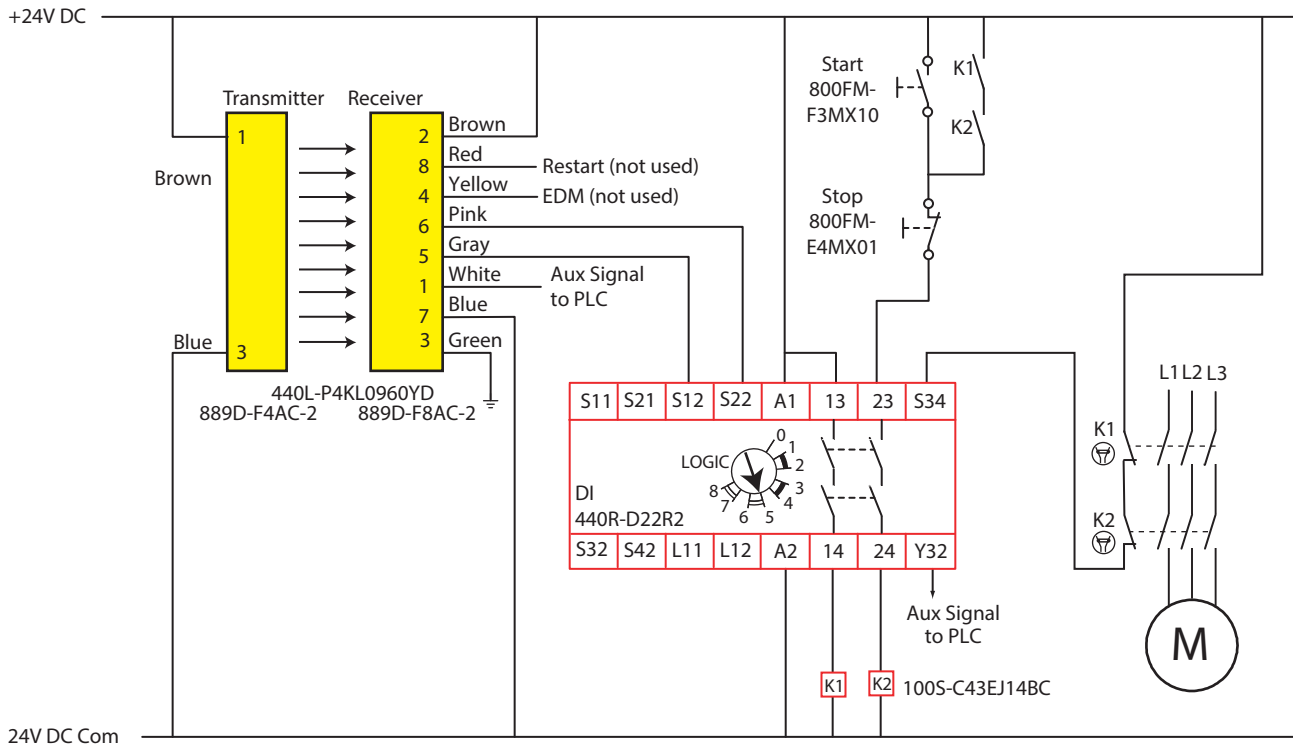

## Two Light Curtains — Point of Operation Control

### Circuit Components

- GuardShield light curtains
- DI safety relay
- Bulletin 800F push buttons
- Bulletin 100S contactor

### Circuit Status

The light curtains are configured with factory default settings (guard-only mode). The light curtains are unobstructed. The outputs of the safety relay are closed, and the motor is ready to run. The DI safety relay is set for Logic 6: [(IN1 AND IN2) OR L12] with Automatic Reset.

### Operating Principle

**STARTING:** Press the Start button to energize contactor K2. The motor starts with the two normally open contacts of K1 and K2 holding the circuit energized.

**STOPPING:** Obstructing either light curtain de-energizes the safety outputs of the DI safety relay which in turn drops out K1 and K2. The contactors disconnect the motor from its power source, and the motor coasts to a stop. Clearing the obstruction in either light curtain does not cause the motor to energize (the Start button must be pressed). The motor can also be turned off by pressing the Stop button.

### Fault Detection

Upon successful completion of internal checks on power-up, the GuardShield light curtains energize their outputs with no objects present. If a cross fault is detected, the GuardShield light curtain goes to a lockout state with its outputs OFF. After successful completion of internal checks, the DI safety relay checks the signals from the light curtains. If OK, the DI safety relay then checks the status of the K1 and K2 contactors. If either K1 or K2 fails in the actuated state, the other contactor disconnects the motor. The DI safety relay detects the faulted contactor and does not allow the motor to restart until the fault is corrected.

The safety system controls contactor K1. The machine control system and the safety system control contactor K2. This configuration increases the probability of performance of the safety function because K1 and K2 are less likely to weld simultaneously due to the diversity of expected wear out times.

### Ratings

The GuardShield light curtains initiate a safety function that meets the safety performance requirements of SIL CL 3 per IEC 62061:2005 and has a Category 4 structure that can be used in systems that require Performance Levels up to PLe per ISO 13849-1:2006. This circuit executes a Stop Category 0.

**Figure 15 - Two Light Curtains — Point of Operation Control**

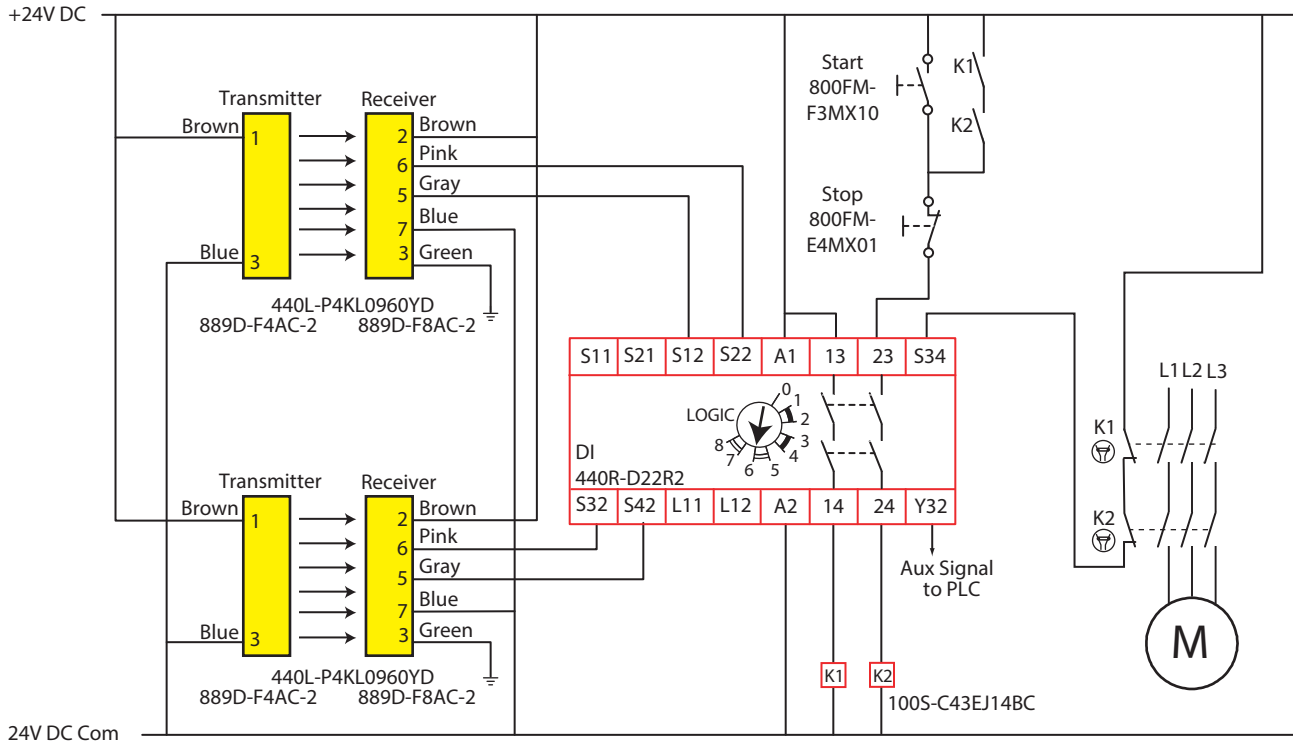

## Lifeline

### Circuit Components

- Lifeline™ cable pull switches
- DI safety relay
- Bulletin 800F push buttons
- Bulletin 100S contactor

### Circuit Status

Both Lifeline cable pull switches are taut and reset; their contacts are closed. The DI Logic setting is 6: [(IN1 AND IN2) OR L12] with automatic reset. The DI safety relay is energized, as its inputs and monitoring circuits are satisfied. The motor is off and ready to run.

### Operating Principle

Two cable pull switches are used to help protect an area from 10...70 m (32.8...229.7 ft) long. Auxiliary lights provide indication as to which switch has been actuated to stop the motor. The difference between the two switches is the conduit thread and shown for examples purposes.

**STARTING:** Press the Start button to energize contactors K1 and K2. The motor starts and the two normally open contacts of K1 and K2 close to hold the circuit energized across the Start button.

**STOPPING:** Pull the Lifeline cable or press the E-stop button on the Lifeline switch to de-energize the outputs of the DI safety relay and turn off the motor. To restart the motor, make sure that the area is clear of hazards, pull out the E-stop button (if pressed), and rotate the reset knob to the Run position.

Then press the Start button to start the motor. As an alternative, the motor can be stopped by pressing the Stop button. It can then be restarted by pressing the Start button.

### Fault Detection

Upon successful completion of internal checks on power-up, the DI safety relay checks its input circuits. With both Lifeline switches reset, the DI safety relay checks the output contactors through the K1/K2/S34 circuit. If the contactors are off, the DI safety relay energizes its outputs and turns on the contactors, which turn on the motor. The DI safety relay detects a short or open circuit fault in the Lifeline cable pull switches. If either the K1 or K2 faults in the energized state, the other contactor stops the motor and the DI detects a fault on the next attempt to restart. The DI safety relay detects its own internal faults. Depending on the type of fault, the result is de-energization of the K1 and K2 contactors or prevention of restart.

### Ratings

The Lifeline cable pull switches initiate a safety function that meets the safety performance requirements of SIL CL 3 per IEC 62061:2005 and has Category 4 structure that can be used in systems that require Performance Levels up to PLe per ISO 13849-1: 2006. The circuit executes a Stop Category 0.

**Figure 16 - Lifeline**

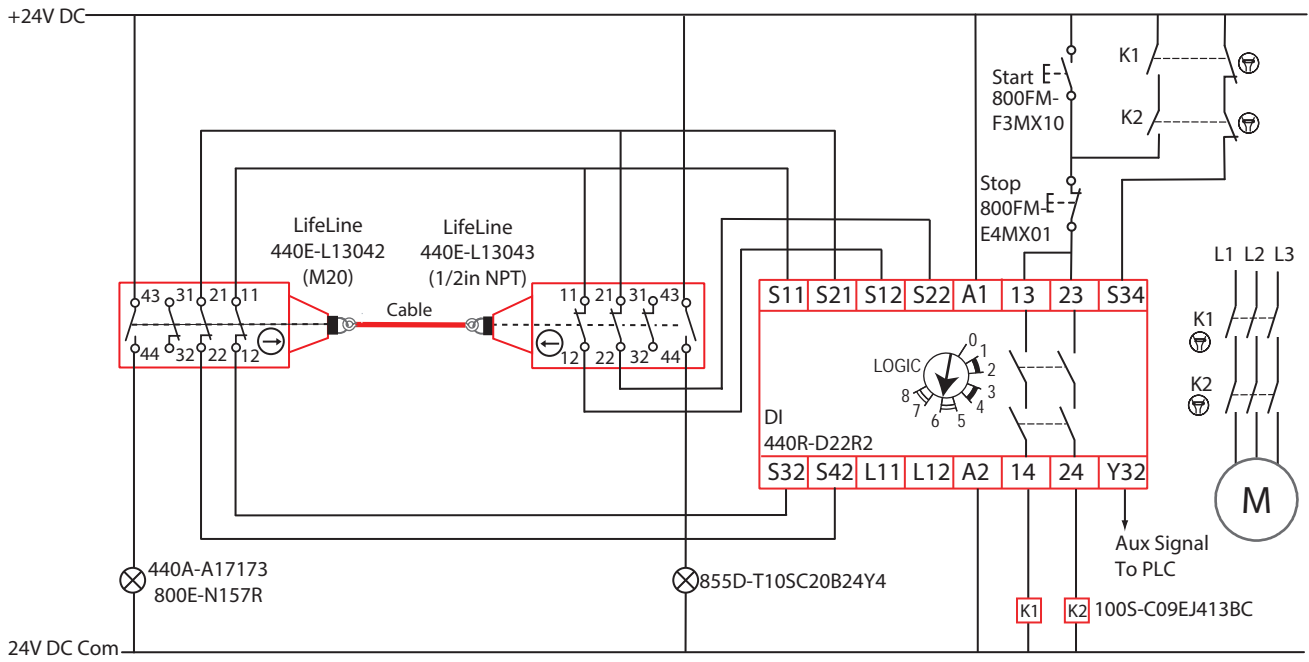

## Safety Distribution Block and DI Safety Relay with Kinetix 350 Drive

### Circuit Components

- SensaGuard non-contact interlock switch
- Safety distribution block
- Bulletin 800F E-stops
- DI safety relay
- Kinetix 350 drive

### Circuit Status

The Logic setting of the DI safety relay is set to 2, monitored manual reset with [(Input 1 AND Input 2) OR L12]. The E-stop is released and connected to Input 1 (S12 and S22). The SensaGuard switches are closed and are connected in series through the Distribution Block to Input 2 (S32 and S42). The PLC monitors the status of each SensaGuard. The DI safety outputs (14 and 24) are OFF. The Kinetix 350 Drive is powered but the safety inputs are off; therefore the motor is OFF. The Y32 Aux Signal and three status signals are OFF and inform the PLC that the safety system is ready to run. The PLC turns ON an output that enables the Reset of the safety system.

### Operating Principle

**STARTING:** Press the Reset button to energize the safety outputs of the DI safety relay. The Y32 and three status signals turn OFF. The Kinetix 350 drive is enabled. The PLC can now turn the motor ON (not shown in [Figure 17](#)).

**STOPPING:** Open any gate or press any E-stop to de-energize the safety outputs of the DI safety relay, which in turn causes the output of the Kinetix drive to turn OFF. The motor coasts to a stop.

### Fault Detection

Upon successful completion of internal checks on power-up, the DI safety relay, Kinetix 350 drive, and SensaGuard interlock switch components are prepared for operation. The SensaGuard interlocks generate test pulses to check for short-circuit faults to power and ground. The DI safety relay generates test pulses through the E-stop circuit to check for short-circuit faults to power and ground.

### Ratings

The SensaGuard interlocks and the E-stop buttons initiate safety functions that can meet the safety performance requirements of SIL CL 2 per IEC 62061:2005 and Performance Level PLd per ISO 13849-1:2008. This circuit executes a Stop Category 0.

**Figure 17 - Safety Distribution Block and DI Safety Relay with Kinetix 350 Drive**

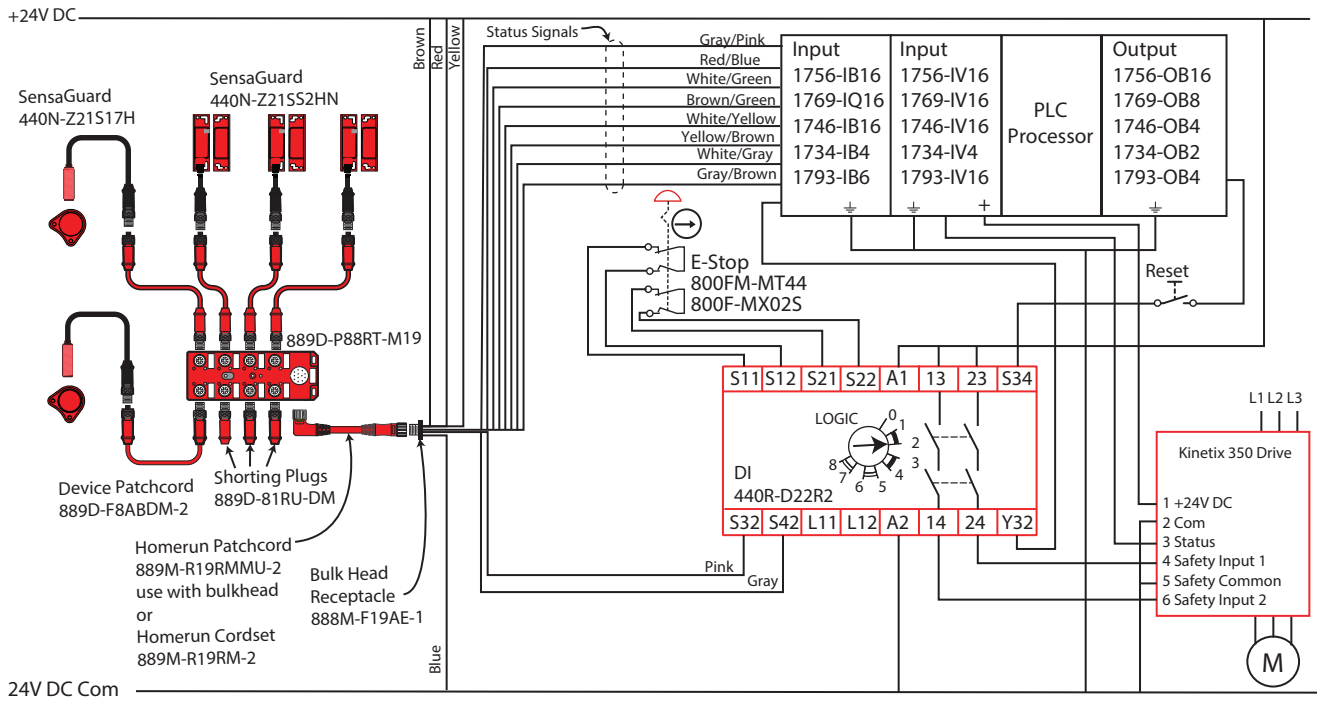

## Safety Valve — Air Supply Release

### Circuit Components

- GuardShield light curtain
- Bulletin 800F E-stops
- DI safety relay
- Pneumatic safety valve

### Circuit Status

The light curtain is clear and the E-stop is released. The DI safety relay outputs are off and the pneumatic valve is closed. The DI safety relay Logic is set to 2: [(IN1 AND IN2) OR L12] with monitored manual reset.

### Operating Principle

**STARTING:** Press the Reset button to energize the output contacts of the safety relay. The two solenoids in the valve energize and allow air to flow from the Air Supply to the Air Outlet.

**STOPPING:** Press the E-stop or block the light curtain to de-energize the safety outputs of the DI safety relay, which in turn drops out the solenoids of the safety valve. The valve closes the Air Supply and releases the air pressure to the Air Exhaust. Releasing the E-stop button or clearing the light curtain does not cause the valve to turn back on.

### Fault Detection

Upon successful completion of internal checks on power-up, the DI safety relay checks the E-stop and light curtain status. If an open or short circuit is detected, the DI safety relay does not energize its outputs. If both input circuits are closed, the DI safety relay checks the status of the safety valve. If one or both solenoids of the safety valve are energized, the Status contact is open, and the DI safety relay does not energize its outputs. If both solenoids are de-energized, the Status contact is closed and the DI safety relay Reset button energizes the DI safety outputs and opens the safety valve.

The safety valve performs its own internal checks. If one of the valves remains actuated, gets stuck, or moves too slowly, the Air Outlet flow is redirected to the exhaust. To clear the fault condition, both valves must be de-energized and the valve Reset button pressed.

### Ratings

The Bulletin 800F E-stop and the GuardShield light curtain initiate a safety function that meets the safety performance requirements of SIL CL 3 per IEC 62061:2005 and have a Category 4 structure that can be used in systems that require Performance Levels up to PLe per ISO 13849-1:2006. This circuit performs a Stop Category 0.



**Figure 18 - Safety Valve — Air Supply Release**

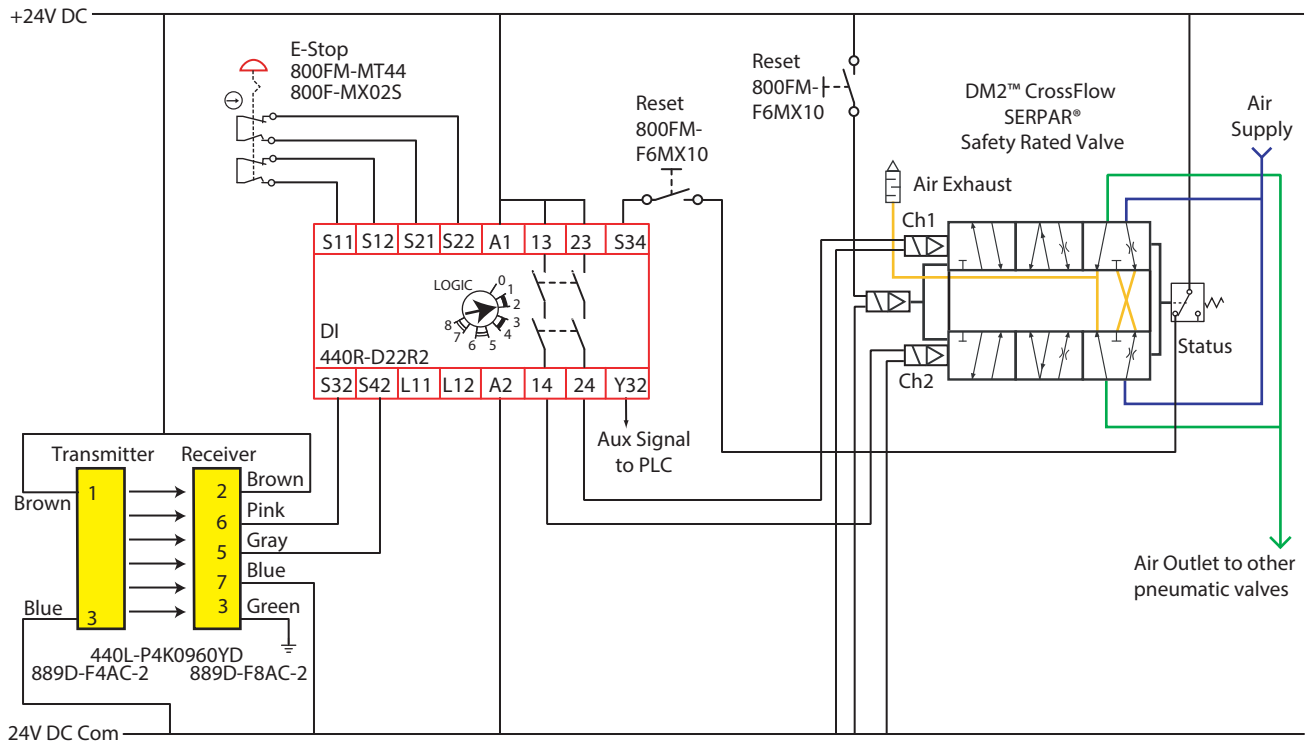

## DI Safety Relay with SensaGuard Integrated Latch and PowerFlex 525 Drive

### Circuit Components

- SensaGuard integrated latch
- Bulletin 800F E-stops
- DI safety relay
- PowerFlex 525 drive

### Circuit Status

The DI safety relay logic is set to 2: [(IN1 AND IN2) OR L12] with monitored reset. The SensaGuard Light Latch interlock is connected to input 1 of the DI safety relay (S12 and S22). The E-stop is connected to input 2 of the DI safety relay (S32 and S42). The gate, monitored by the SensaGuard light latch, is closed and the E-stop is released. The DI safety outputs are off. The PowerFlex 525 drive is powered but disabled. The motor is off.

### Operating Principle

**STARTING:** Press the Reset button to turn on the DI safety outputs. The drive is enabled and power is applied to the Start and Stop buttons. Press the Start buttons to start the motor.

**STOPPING:** Press the Stop button to stop the motor for production stops. Press the E-stop or open the safety gate to initiate a safety stop; the motor coasts to a stop.

### Fault Detection

Upon successful completion of internal checks by the DI safety relay, SensaGuard latch, and PowerFlex 525 drive, the drive awaits the closure of the safety outputs. If the DI safety relay fails, the drive does not energize the motor, and non-operation of the motor indicates the fault. The DI safety relay generates test pulses through the E-stop circuits to detect cross channel shorts and shorts to power and ground. The SensaGuard latch generates test pulses on its outputs to detect cross channel shorts and shorts to power and ground. The drive detects a fault in the safe-circuit of the drive and the drive issues a safety stop.

### Ratings

The SensaGuard latch and the E-stop initiate safety functions that meet the safety performance requirements of SIL CL 2 per IEC 62061:2005 and category 3 structure that can be used in systems that require Performance Levels up to PLd per ISO 13849-1: 2006. The circuit executes a Stop Category 0.

**Figure 19 - DI Safety Relay with SensaGuard Integrated Latch and PowerFlex 525 Drive**

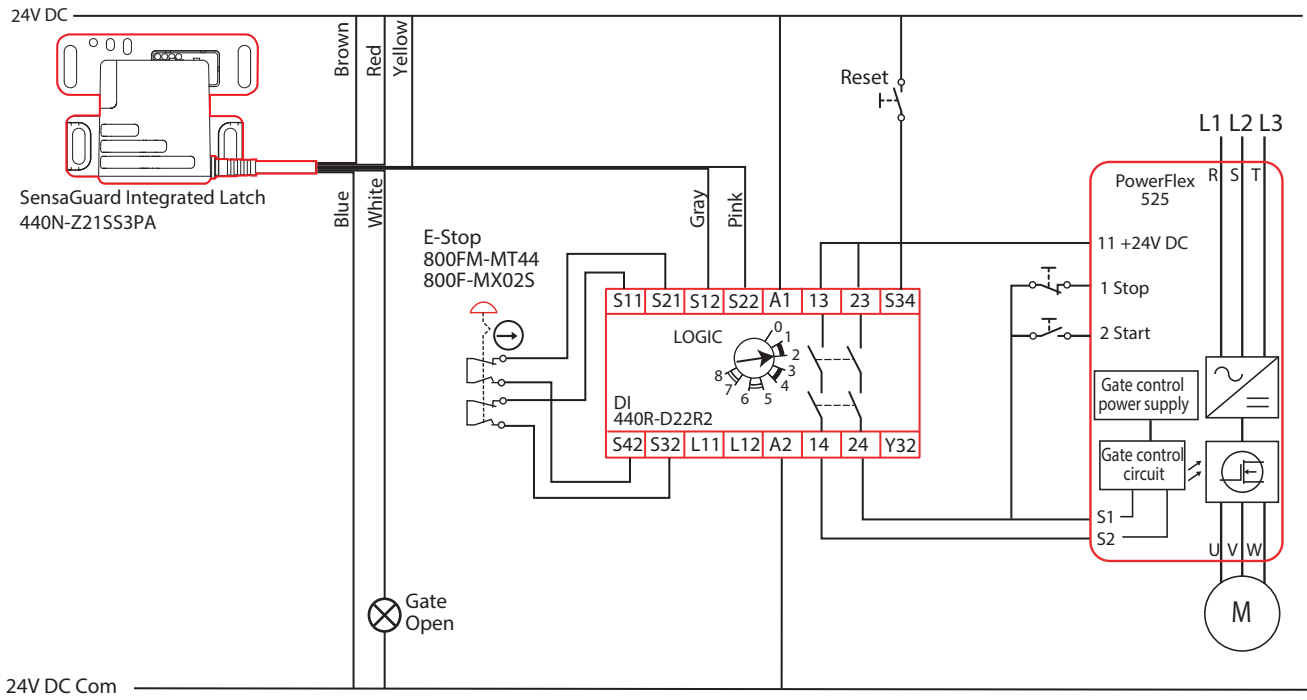

## Interlock Switch with Enabling Device—Guard Locking with Time Delay

### Circuit Components

- Bulletin 440J grip enabling switch
- MT-GD2 latch release
- Bulletin 440G-MT guard locking switch
- Bulletin 800F E-stops
- GLT, EM, SI, and EMD safety relays
- Bulletin 100S contactor

### Circuit Status

The Bulletin 440J grip enabling switch is held by one MT-GD2 tongue interlock by its mounting plate accessories. The enabling switch is disabled when it is mounted in the MT-GD2 switch. The Bulletin 440G-MT guard locking switch closes and locks the safety gate.

The GLT safety relay is set for Stop Cat 0 (Logic =1) and a time delay of 4 seconds (Range = 4 and Time =4, 40% of 10 seconds). The SI safety relay is set from automatic reset (AM). The EMD safety relay range switch is set to 8 (Jog 10 seconds) and the Time is set to 6 (60%), therefore the Jog occurs for 6 seconds.

The EM safety relay allows the parallel switching of the contactors from the GLT safety relay or the enabling switch. If the EM safety relay is not used and K1 and K2 are connected to terminals 14 and 24 of the GLT safety relay, the GLT safety relay faults when the enabling switch is used because the 14 and 24 terminals detect a short circuit to 24V.

Due to the higher solenoid current of the Bulletin 440G-MT guard locking switch, the interposing relay CR1 is required.

Contactors K1 and K2 are de-energized. The motor is off and the application ready to run.

### Operating Principle

With the safety gate unlocked, you can remove the enabling switch from its holder and jog (energize) the motor for the duration set by the EMD safety relay (6 seconds), by pressing and holding the Jog switch. After the EMD safety relay time expires, you can jog the motor again by releasing and then pressing/holding the Jog button again. When placed in the MT-GD2 interlock, the enabling switch is disabled.

**STARTING:** With the enabling switch placed in the MT-GD2 interlock and the safety gate closed, press the Lock and Reset button. Contactors K1 and K2 turn ON.

**STOPPING:** With the enabling switch placed in the MT-GD2 interlock, press the Unlock Request. Contactors K1 and K2 turn off immediately and the motor coasts to a stop. After a 4-second delay, the safety gate is unlocked.

If the enabling switch is removed from the MT-GD2 holder while the motor is ON, contactors K1 and K2 turn off immediately. The safety gate remains locked. The motor can still be jogged with the enabling switch. The GLT safety relay shows a recoverable fault state; the PWR/Fault status indicator is green with five red flashes. You must put the enabling switch back in the MT-GD2 holder and press the Reset button to clear the fault. Press the Reset button again to turn the contactors ON.

**STOPPING DURING JOG:** Release the Jog switch. Also, if you release or squeeze the trigger switch on the enabling switch the contactors turn OFF. The motor coasts to a stop.

### Fault Detection

Upon successful completion of internal checks on power-up, the GSR modules check external devices. The GLT safety relay checks for dual pulse-tested input signals from the interlock and potential short circuits on its outputs (51, L61, and L11). If the inputs are closed, and no short circuits exist, the GLT safety relay waits for the reset signal. The reset signal is sourced from X32 of the EM safety relay. If the EM safety relay has a fault, the X32 output remains OFF, and the GLT safety relay cannot turn on its L11 output.

The SI safety relay checks for dual pulse-tested input signals from the MT-GD2 interlock and the enabling switch. If the input signals are closed, the SI safety relay checks the reset circuit. If K1 and K2 are both OFF, then the SI safety relay turns its L11 output ON. If K1 or K2 becomes faulted in an energized position, the SI safety relay does not turn on.

When not used, the enabling switch is placed in the MT-GD2 interlock. This placement helps prevent inadvertent jogging of the motor when the enabling switch is not needed.

### Ratings

The Bulletin 440G-MT guard locking interlock initiates a safety function that meets the safety performance requirements of SIL CL 2 per IEC 62061:2005 and has Category 3 structure that can be used in systems that require Performance Levels up to PLd per ISO 13849-1: 2006.

The MT-GD2 interlock and the enabling switch button initiate a safety function that meets the safety performance requirements of SIL CL 2 per IEC 62061:2005 and has Category 3 structure that can be used in systems that require Performance Levels up to PLd per ISO 13849-1: 2006. This circuit performs a Stop Category 0.

**Figure 20 - Interlock Switch with Enabling Device—Guard Locking with Time Delay**

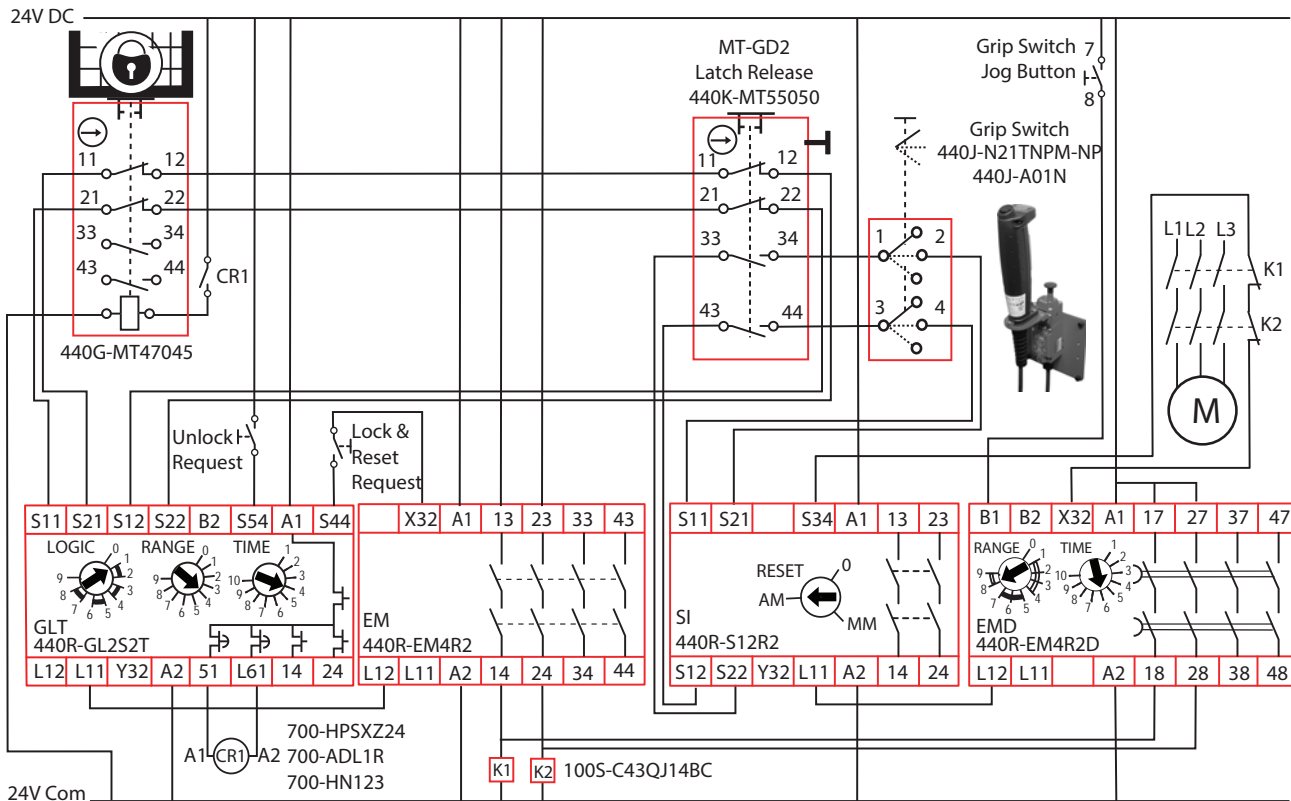

## DI/EMD Safety Relays with Enabling Jog System

### Circuit Components

- Bulletin 440G-MT guard locking switch
- Bulletin 440J grip enabling switch
- DI and EMD safety relays
- PowerFlex DriveGuard®

### Circuit Status

The Bulletin 440J grip enabling switch is held by two MT-GD2 interlocks. The DI safety outputs are closed. The PowerFlex Enable and Safe Torque Off option are energized. The EMD safety outputs are de-energized. The DI Logic is set to 5: [(IN1 OR IN2) OR L12] with automatic reset. The EMD Range switch is set to 8 (Jog 10 seconds) and the Time is set to 2 (20%), therefore the Jog occurs for 2 seconds. The motor is ready to run.

### Operating Principle

The EMD safety relay is chosen for its ability to perform timing functions. In this case, the EMD safety relay is configured to jog the PowerFlex drive with one pulse having a duration set between 0.5...10 seconds. Adjustments to the pulse are made by potentiometers on the EMD safety relay. While in the MT-GD2 holder, the enabling switch is disabled and the machine control system can control the drive. The machine control system disables the Jog switch.

**STARTING:** As shown, the PowerFlex drive is ready to run. Press the Start button.

**JOGGING:** Close the three-position enabling switch to close the outputs of the DI safety relay and enable the drive. Remove the enabling switch from the MT-GD2 holder. The machine control system is notified that the enabling switch has been removed and enables the jog switch. Press the Jog button on the enabling switch to initiate the operation of the EMD safety relay. The EMD safety relay closes its safety outputs for the set duration. The Jog button must be held closed during the jog time.

**STOPPING:** The jog function stops after the set time expires. To restart, momentarily release the Jog button and then reclose it to repeat the jog. Release or squeeze the three-position enabling switch to open the outputs of the DI safety relay and causes the PowerFlex drive to execute a coast-to-stop.

### Fault Detection

Upon successful completion of internal checks by the DI and EMD safety relays and the PowerFlex drive, the drive awaits the closure of the EMD safety outputs. If the DI safety relay fails, the drive does not energize the motor and non-operation of the motor indicates the fault. The DI safety relay uses dual channel to detect faults to power, ground, and cross-channel faults on the enabling switch or the MT-GD2 interlock. The EMD safety relay detects a short across the jog switch and helps prevent subsequent jog attempts. The DI safety relay detects a fault in the Safe Torque Off option of the drive on the next attempt to restart the drive. Internal faults in the DI safety relay result in non-operation of the motor. Internal faults of the DI safety relay result in non-operation of the jog function.

### Ratings

The enabling switch initiates a safety function that meets the safety performance requirements of SIL CL 2 per IEC 62061:2005 and has Category 3 structure that can be used in systems that require Performance Levels up to PLd per ISO 13849-1: 2006. The circuit executes a Stop Category 0.

Figure 21 - DI/EMD Safety Relays with Enabling Jog System

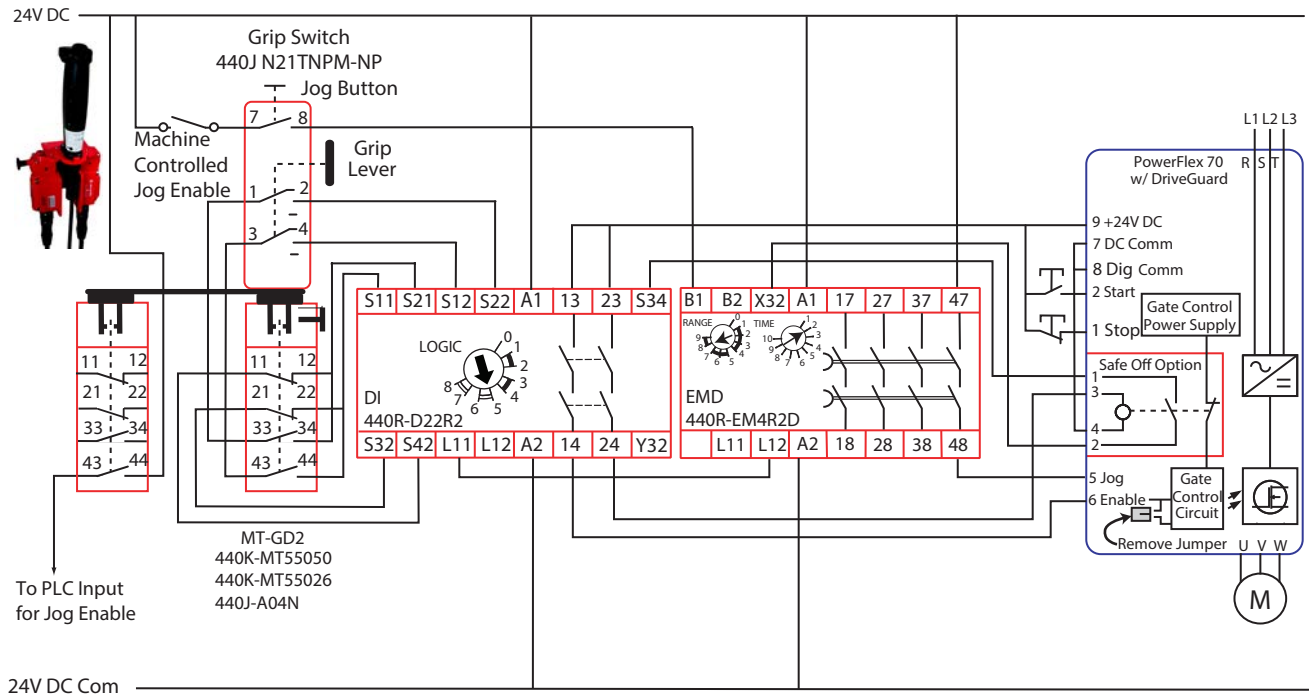

## Guard Locking with DI/EMD Safety Relays

### Circuit Components

- Bulletin 800F E-stop
- TLS1-GD2 guard locking switch
- Trojan T15-GD2 tongue interlock switch
- DI and EMD safety relays
- Bulletin 100S safety contactor

### Circuit Status

The E-stop is reset and the safety gate is closed and locked. The outputs of the safety relays are open, and the motors are off. The rotary switches of the EMD safety relay have the delay time set to 18 seconds (Range 3: 30 seconds OFF Delay, Time 6: 60% of range). The EMD safety relay opens its contacts 18 seconds after the signal from the DI L11 output turns off.

### Operating Principle

**STARTING:** Press the Reset button to energize the outputs of the DI safety relay. The outputs of the DI safety relay energize the K1 and K2 control relays and motor M1 starts. Simultaneously, the DI safety relay sends a signal via L11 to the EMD safety relay. The outputs of the EMD safety relay energize the K3 and K4 control relays and motor M2 starts.

**STOPPING:** When the E-stop is pressed, the outputs of the DI safety relay open and motor M1 coasts to stop. After the time delay of the EMD safety relay expires, motor M2 coasts to a stop and the Y32 output energizes. The gate can be unlocked by pressing the Gate Release button. Press the Gate Release button to power the solenoid and open the Gate. Closing the gate or resetting the E-stop does not re-energize the Bulletin 100S safety contactors.

### Fault Detection

Upon power-up, the DI and EMD safety relays perform internal checks. The DI safety relay then looks for signals from the E-stop and the TLS1-GD2 guard locking switch and Trojan T15 tongue interlock switch. The E-stop has a self-monitoring contact, which opens if the contact block falls off the control panel. With the E-stop signals made, the DI safety relay checks the K1, K2, K3, K4, and TLS1 monitoring circuit when the Reset button is pressed. If these checks are OK, the output energizes. The Reset button is linked to the delayed Y32 output to supply +24V for reset only when delay time has lapsed. If any DI safety relay contacts faults to the ON state, the redundant outputs stop the motor. The Y32, K1, K2, K3, K4, and TLS1 monitoring circuit detects the fault on the next attempt to restart. If the gate is not interlocked by the TLS1 solenoid or one of the 100S safety contactors faults to the ON state, the DI safety relay detects the fault in the Y32, K1, K2, K3, K4, and TLS1 monitoring circuit on the next attempt to reset. An additional interlock (Trojan T15) is added to the gate to help prevent potential single-point failures that are related to tongue style interlocks.

### Ratings

The gate interlocks and the E-stop initiate a safety function that meets the safety performance requirements of SIL CL 3 per IEC 62061:2005 and has a Category 4 structure that can be used in systems that require Performance Levels up to PLe per ISO 13849-1:2006. This circuit executes Stop Category 0.





## Guard Locking with DI/EMD Safety Relays

### Circuit Components

- MAB
- Bulletin 800F E-stop
- DI and EMD safety relays
- Bulletin 100S contactor

### Circuit Status

The E-stop is reset. The safety gate is closed and locked. The outputs of the safety relays are open, and the motors are off. The rotary switches of the EMD safety relay have the delay time set to 18 seconds (Range 3: 30 seconds OFF Delay, Time 6: 60% of range). The EMD opens its contacts 18 seconds after the signal from the DI L11 output turns off. The EMD safety relay retriggerable input B2 is not needed because the DI safety relay cannot turn on its outputs until after the EMD safety relay timer expires.

### Operating Principle

**STARTING:** Press the Reset button to energize the outputs of the DI safety relay. The outputs of the DI safety relay energize the K1 and K2 contactors and motor M1 starts. Simultaneously, the DI safety relay sends a signal via L11 to the EMD safety relay. The outputs of the EMD safety relay energize the K3 and K4 contactors and motor M2 starts.

**STOPPING:** When the E-stop is pressed, the outputs of the DI safety relay open and motor M1 coasts to stop. After the time delay of the EMD safety relay expires, motor M2 coasts to a stop and the Y32 output energizes. The gate can be unlocked by closing the Unlock selector switch.

### Fault Detection

Upon power-up, the MAB, DI relay, and EMD relay perform internal checks. The DI safety relay then looks for signals from the E-stop and the MAB. With the E-stop signals made, the DI relay checks the K1, K2, K3, K4 monitoring circuit when the Reset button is pressed. If these checks are OK, the output energizes. The MAB has pulse tested outputs to detect wiring faults. The MAB Fault Reset clears faults within the MAB.

### Ratings

The gate interlocks and the E-stop initiate a safety function that meets the safety performance requirements of SIL CL 3 per IEC 62061:2005 and has a Category 4 structure that can be used in systems that require Performance Levels up to PLe per ISO 13849-1:2006. This circuit executes Stop Category 0.

**Figure 23 - Guard Locking with DI/EMD Safety Relays**

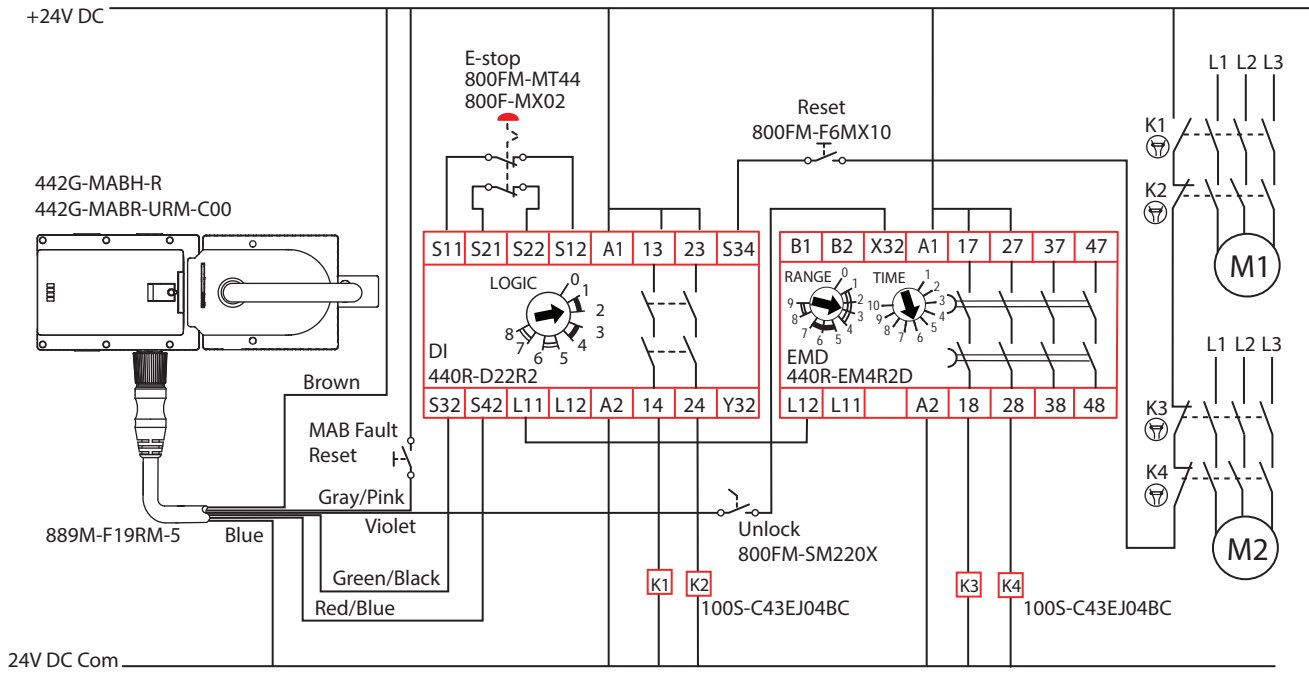

## Global E-stop and Zone Control

### Circuit Components

- GuardShield light curtains
- SensaGuard non-contact interlock switch
- Bulletin 440F MatGuard safety mats
- Bulletin 800F E-stops
- DI safety relays
- Bulletin 100S contactor

### Circuit Status

The light curtains are unobstructed. The safety gate is closed. The E-stops are reset, and the safety mat is unoccupied. The outputs of all three DI safety relays are off. K1...K6 are ready to be energized.

### Operating Principle

The DI safety relay is chosen for its zoning capability. The two E-stops operate globally, turning off relays 1, 2, and 3.

**STARTING:** Press the Reset button for relay 1 to energize its outputs. Then, press the Reset button for relays 2 and 3 to energize their respective outputs.

**STOPPING:** Obstructing light curtain A or stepping on the safety mat turns off the outputs of relay 2 while leaving the outputs of relay 1 and relay 3 energized. Obstructing light curtain B or opening the safety gate with the SensaGuard interlock turns off the outputs to relay 3 while leaving the outputs of relay 1 and relay 2 energized. Pressing either E-stop shuts down all three relays.

### Fault Detection

Upon successful completion of internal checks on power-up, the DI safety relays check their input circuits. Shorts from the inputs to power, ground, or other inputs are detected immediately and prevent energization or de-energize the respective outputs. If one of the Bulletin 100S or Bulletin 700S output devices (K1...K6) is stuck in an actuated state, the respective DI safety relay prevents startup because the S34 feedback loop remains open. For fault detection purposes, all GSR modules that are used in safety mat applications must be configured for monitored manual reset.

### Ratings

The input devices, except the safety mat, initiate safety functions that meet the safety performance requirements of SIL CL 3 per IEC 62061:2005 and have Category 4 structures that can be used in systems that require Performance Levels up to PLe per ISO 13849-1:2006.

The safety mat initiates a safety function that meets the safety performance requirements of SIL CL 2 per IEC 62061:2005 and has a Category 3 structure that can be used in systems that require Performance Levels up to PLd per ISO 13849-1:2006. This circuit executes a Stop Category 0.

**Figure 24 - Global E-stop and Zone Control**

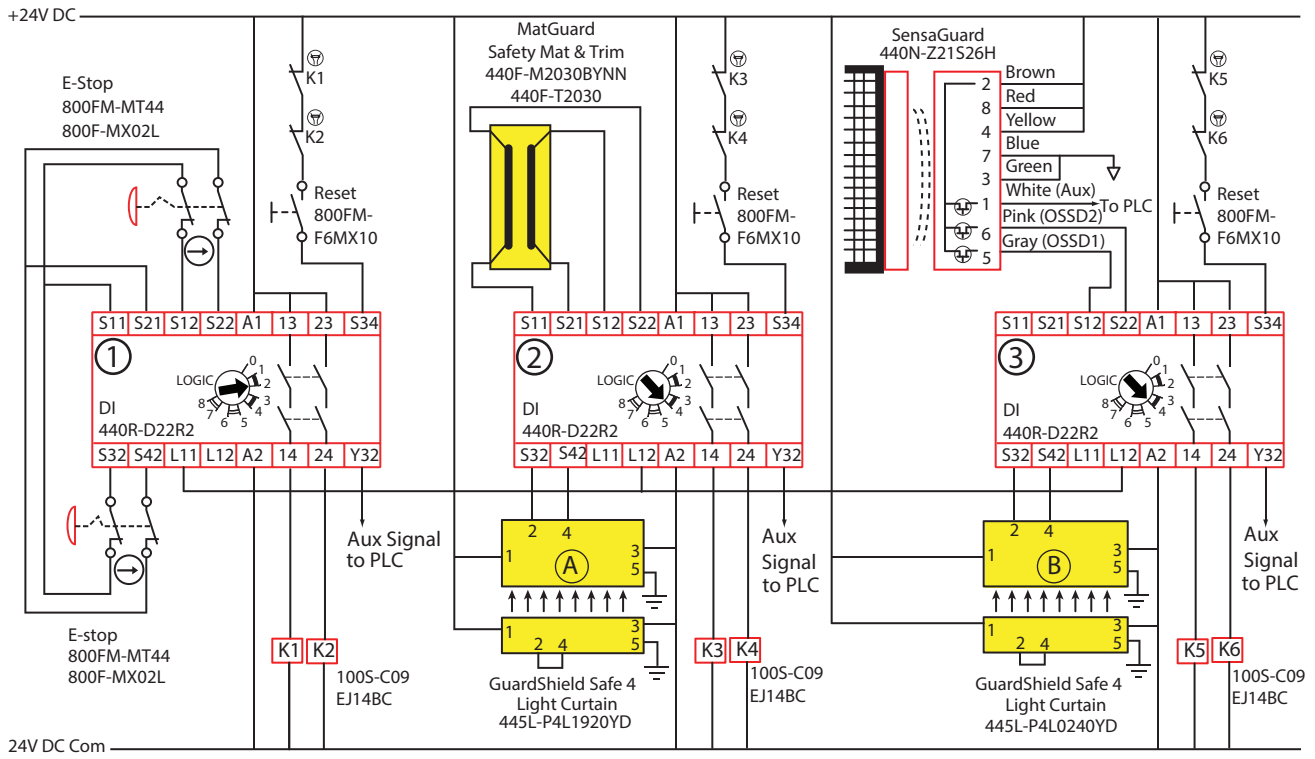

## E-stops for a PowerFlex 755 Drive

### Circuit Components

- Bulletin 440F MatGuard safety mats
- DI safety relay
- PowerFlex 755 drive

### Circuit Status

Both safety mats are clear. The safety outputs of the DI safety relay are de-energized. The PowerFlex 755 drive is powered and its safety circuit is disabled. The motor is off. The DI safety relay has a Logic setting of 2: [(IN1 AND IN2) OR L12] with monitored manual reset.

---

**IMPORTANT** The safety mat wiring must be crossed as compared to an E-stop button: S11 connects to S22 & S42 and S21 connects to S12 & S32, and safety mat applications require Logic settings with IN1 AND IN2.

---

### Operating Principle

**STARTING:** Press the Reset button to energize the safety outputs of the DI safety relay and enable the PowerFlex 755 drive. Press the Start button to start the motor.

**STOPPING:** The Stop switch or other equivalent machine control system (not shown) stops normal production. Stepping on either safety mat initiates a safety stop. The DI safety relay removes power to the Start/Stop circuit and the Gate Control Circuit. The motor executes a Safe Torque Off function and the motor coasts to a stop.

### Fault Detection

Upon power-up, the PowerFlex drive and DI safety relay perform internal checks. The DI safety relay then looks for dual signals from the safety mats. A cross fault (channel 1 to channel 2) is equivalent to stepping on the safety mat. The DI safety relay is rated for Category 4 and does not lose the safety function due to an accumulation of faults. The PowerFlex 755 drive is rated at Category 3, as it performs the safety function in the presence of one internal fault. For fault detection purposes, all GSR modules that are used in safety mat applications must be configured for monitored manual reset.

### Ratings

The safety mats initiate a safety function that meets the safety performance requirements of SIL CL 2 per IEC 62061:2005 and has a Category 3 structure that can be used in systems that require Performance Levels up to PLd per ISO 13849-1:2006. This circuit executes a Safe Torque Off (Stop Category 0).

**Figure 25 - E-stops for a PowerFlex 755 Drive**

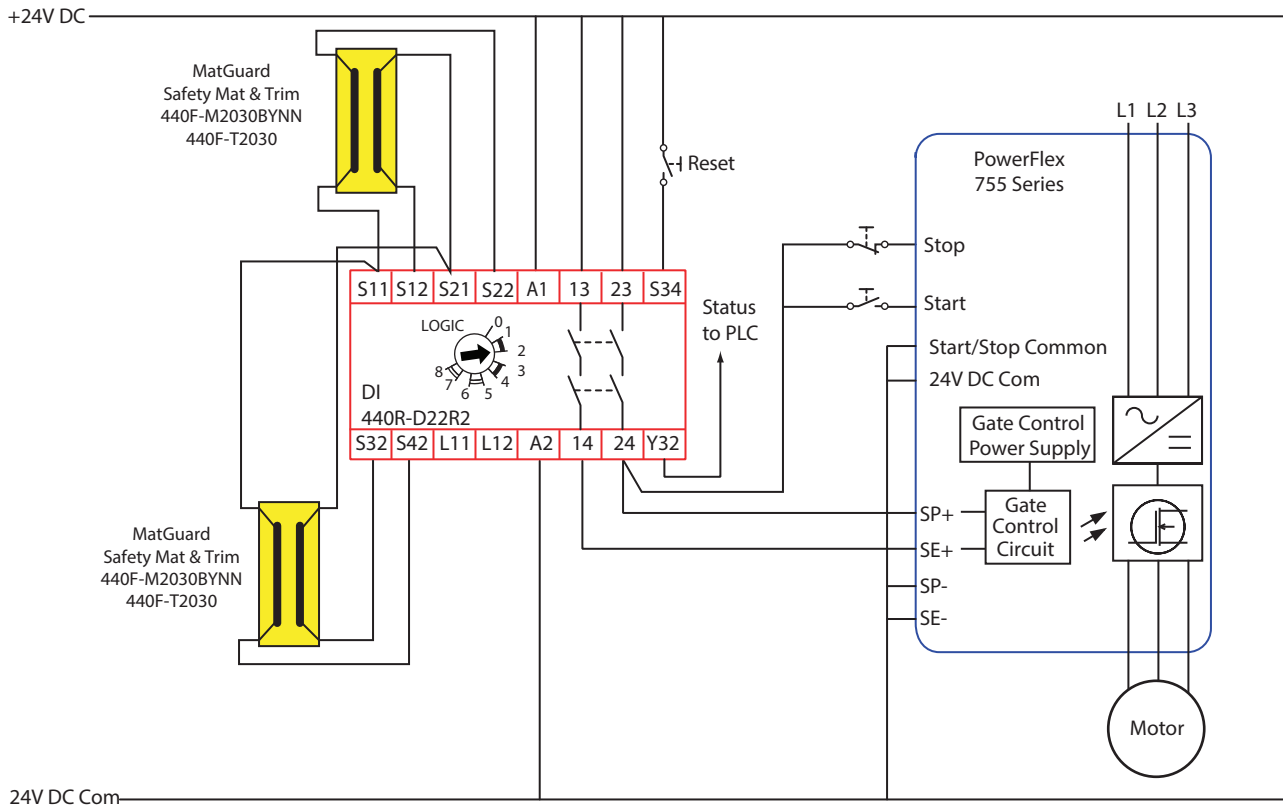

## SafeZone Mini Laser Scanner, E-stop, and DI Safety Relay with Kinetix 350 Drive

### Circuit Components

- SafeZone™ Mini safety laser scanner
- Bulletin 800F E-stops
- DI safety relay
- Kinetix 350 drive

### Circuit Status

The Logic setting of the DI safety relay is set to 2 - monitored manual reset with [(Input 1 AND Input 2) OR L12]. The E-stop is in the released position and is connected to Input 2 (S32 and S42) of the DI safety relay. The scan area of the SafeZone Mini scanner is clear and the signals to Input 1 of the DI (S12 and S22) are high. The Warning Field signal is connected to a PLC, which turns on an indicator and can also perform other logic. The DI safety outputs (14 and 24) are OFF. The Kinetix 350 Drive is powered but the safety inputs are off; therefore the motor is OFF. The Y32 Aux Signal is high, which informs the PLC that the safety system is ready to run.

### Operating Principle

**STARTING:** Press the Reset button to energize the safety outputs of the DI safety relay. The Y32 status signal turns OFF. The Kinetix 350 drive is enabled. The PLC can now turn the motor ON (not shown in [Figure 26](#)).

**STOPPING:** Entering the warning field of the SafeZone Mini scanner does not cause the safety system to turn off; but the PLC turns on an indicator. Entering the protective field of the SafeZone Mini scanner or pressing the E-stop causes the DI safety relay to turn OFF, which disables the Kinetix 350 drive. The motor coasts to a stop.

### Fault Detection

Upon successful completion of internal checks on power-up, the SafeZone Mini scanner, DI safety relay, and Kinetix 350 drive are prepared for operation. The safety outputs of the SafeZone Mini generates test pulses to check for cross channel shorts and short-circuit faults to power and ground. The DI safety relay generates test pulses through the E-stop circuit to check for cross channel shorts and short-circuit faults to power and ground.

---

**IMPORTANT** Do not replace the DI safety relay with the DIS safety relay as the pulse checking on the outputs of the DIS safety relay causes an F059 fault on the Kinetix 350 drive safety inputs.

---

### Ratings

The SafeZone Mini scanner and the E-stop buttons initiate safety functions that can meet the safety performance requirements of SIL CL 2 per IEC 62061:2005 and has a Category 3 structure that can be used in systems that require Performance Level up to PLd per ISO 13849-1:2006. This circuit executes a Stop Category 0.



**Figure 26 - SafeZone Mini Laser Scanner, E-stop, and DI Safety Relay with Kinetix 350 Drive**

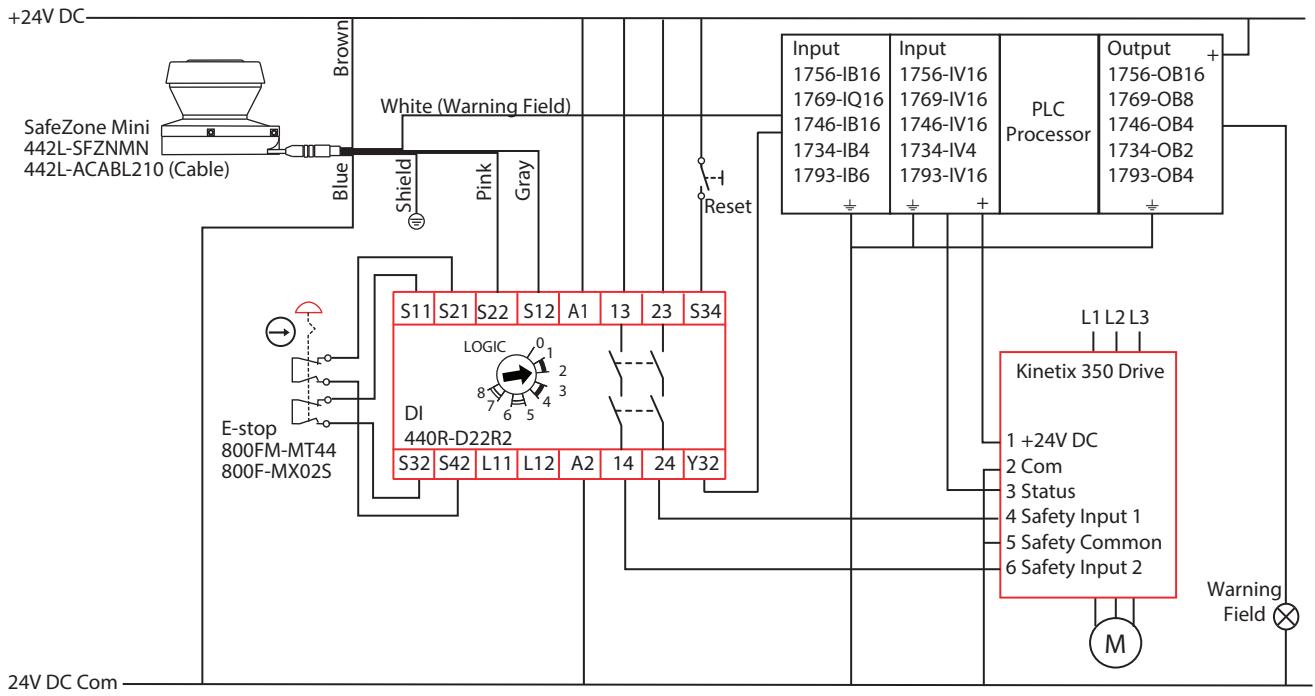

## Multizone Laser Scanner, E-stop, and DI Safety Relay with Kinetix 350 Drive

### Circuit Components

- SafeZone multizone safety laser scanner
- Bulletin 800F E-stops
- DI safety relay
- Kinetix 350 drive

### Circuit Status

The Logic setting of the DI safety relay is set to 2 - monitored manual reset with [(Input 1 AND Input 2) OR L12]. The E-stop is in the released position and is connected to Input 2 (S32 and S42) of the DI safety relay. The scan area of the SafeZone multizone scanner is clear and the signals to Input 1 of the DIS safety relay (S12 and S22) are high. The Warning Field signal is connected to a PLC, which turns on an indicator and can also perform other logic. The DI safety outputs (14 and 24) are OFF. The Kinetix 350 drive is powered but the safety inputs are off; therefore the motor is OFF. The Y32 Aux Signal is high, which informs the PLC that the safety system is ready to run.

### Operating Principle

The PLC sends a pair of signals (a N.C. and a N.O.) to the SafeZone multizone scanner to switch the active zones between Zones A and B. The OSSD outputs respond to either zone.

**STARTING:** Press the Reset button to energize the safety outputs of the DI safety relay. The Y32 status signal turns OFF. The Kinetix 350 drive is enabled. The PLC can now turn the motor ON (not shown in [Figure 27](#)).

**STOPPING:** Entering the warning field of the SafeZone multizone scanner does not cause the safety system to turn off; but the PLC turns on an indicator. Entering the protective field of the SafeZone multizone scanner or pressing the E-stop causes the DI safety relay to turn OFF, which disables the Kinetix 350 drive. The motor coasts to a stop.

### Fault Detection

Upon successful completion of internal checks on power-up, the SafeZone multizone scanner, DIS safety relay, and Kinetix 350 drive are prepared for operation. The safety outputs of the SafeZone multizone scanner generates test pulses to check for cross channel shorts and short-circuit faults to power and ground. The DI safety relay generates test pulses through the E-stop circuit to check for cross channel shorts and short-circuit faults to power and ground.

---

**IMPORTANT** Do not replace the DI safety relay with the DIS safety relay as the pulse checking on the outputs of the DIS safety relay causes an F059 fault on the Kinetix 350 drive safety inputs.

---

### Ratings

The SafeZone multizone scanner and the E-stop buttons initiate safety functions that can meet the safety performance requirements of SIL CL 2 per IEC 62061:2005 and has a Category 3 structure that can be used in systems that require Performance Levels up to PLd per ISO 13849-1:2006. This application executes a Stop Category 0.

**Figure 27 - Multizone Laser Scanner, E-stop, and DI Safety Relay with Kinetix 350 Drive**

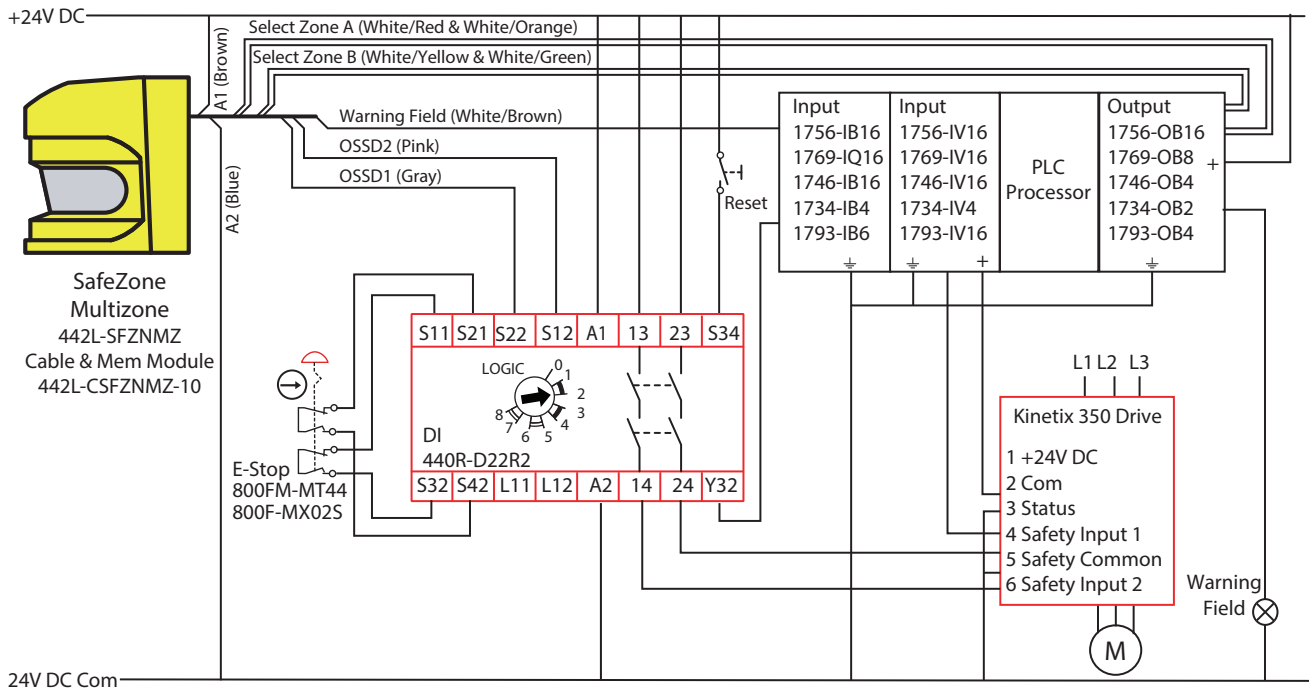

## Safety Sensor, E-stop, and DI Safety Relay with Kinetix 350 Drive

### Circuit Components

- SC300 hand detection safety sensor
- Bulletin 800F E-stops
- DI safety relay
- Kinetix 350 drive

### Circuit Status

The Logic setting of the DI safety relay is set to 2, monitored manual reset with [(Input 1 AND Input 2) OR L12]. The E-stop is in the released position and is connected to Input 2 (S32 and S42) of the DI safety relay. The scan area of the SC300 safety sensor is clear and the signals to Input 1 of the DI safety relay (S12 and S22) are high. The Warning Field signal is connected to a PLC, which turns on an indicator and can also perform other logic. The DI safety outputs (14 and 24) are OFF. The Kinetix 350 drive is powered but the safety inputs are off; therefore the motor is OFF. The Y32 Aux Signal is high, which informs the PLC that the safety system is ready to run.

### Operating Principle

**STARTING:** Press the Reset button to energize the safety outputs of the DI safety relay. The Y32 status signal turns OFF. The Kinetix 350 drive is enabled. The PLC can now turn the motor ON (this circuitry is not shown).

**STOPPING:** Entering the warning field of the SC300 safety sensor does not cause the safety system to turn off; but the PLC turns on an indicator. Entering the protective field of the SC300 safety sensor or pressing the E-stop causes the DI safety relay to turn OFF, which disables the Kinetix 350 drive. The motor coasts to a stop.

### Fault Detection

Upon successful completion of internal checks on power-up, the SC300 safety sensor, DI safety relay, and Kinetix 350 drive are prepared for operation. The safety outputs of the SC300 safety sensor generates test pulses to check for cross channel shorts and short-circuit faults to power and ground. The DI safety relay generates test pulses through the E-stop circuit to check for cross channel shorts and short-circuit faults to power and ground.

---

**IMPORTANT** Do not replace the DI safety relay with the DIS safety relay as the pulse checking on the outputs of the DIS safety relay causes an F059 fault on the Kinetix 350 drive safety inputs.

---

### Ratings

The SC300 safety sensor and the E-stop buttons initiate safety functions that can meet the safety performance requirements of SIL CL 2 per IEC 62061:2005 and has a Category 3 structure that can be used in systems that require Performance Levels up to PLd per ISO 13849-1:2006. This circuit executes a Stop Category 0.

**Figure 28 - Safety Sensor, E-stop, and DI Safety Relay with Kinetix 350 Drive**

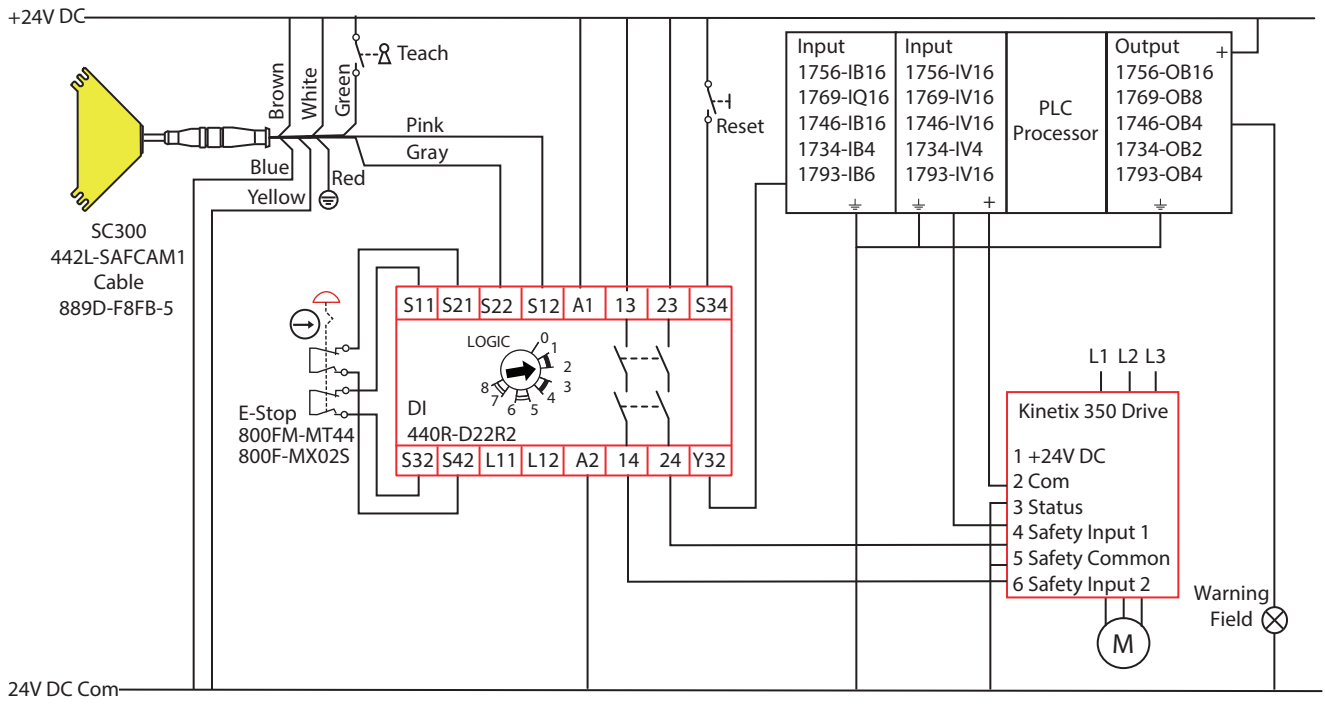

## Hazardous Location

### Circuit Components

- Trojan T15 tongue interlock switch
- Bulletin 800F E-stops
- Bulletin 937TH isolator
- DIS safety relay
- PowerFlex 525 drive

### Circuit Status

The DIS safety relay logic is set to 2: [(IN1 AND IN2) OR L12] with monitored reset. The Trojan T15 switch is connected to input 1 of the DIS (S12 and S22) through the galvanic isolator. The E-stop is connected to input 2 of the DIS safety relay (S32 and S42). The gate is closed and the E-stop is released. The DIS safety outputs are off. The PowerFlex 525 drive is powered but disabled. The motor is off.

### Operating Principle

The galvanic isolator limits energy to the interlock switch, which is considered a simple apparatus in the hazardous location. The DIS safety relay checks the outputs of the galvanic isolator upon power-up and each time the gate/E-stop is actuated.

**STARTING:** Press the Reset button to turn the DIS safety outputs (14, 24, 34, 44 and L11) ON and enable the PowerFlex 525 drive. Press the Start button to turn the motor ON.

**STOPPING:** Normal production stops are performed by pressing the Stop button. Opening the gate or pressing the E-stop initiates a safety stop; the motor coasts to a stop.

### Fault Detection

The DIP switch setting of the galvanic isolator allows for open and short-circuit detection of the Trojan switch circuits. Since the Bulletin 937TH isolator has a hardware fault tolerance of zero, two are used to achieve single fault tolerance. The isolator DIP switches must be set for Line Fault Detection (I) and non-inverted (II) output. The Bulletin 1492 resistors are required to detect line faults. These resistors must be located as close as possible to the interlock switch.

### Ratings

The Trojan T15 switch initiates a safety function that meets the safety performance requirements of SIL CL 2 per IEC 62061:2005 and has a Category 3 structure that can be used in systems that require up to Performance Level PLd per ISO 13849-1:2006.

The E-stop initiates a safety function that meets the safety performance requirements of SIL CL 2 per IEC 62061:2005 and has a Category 3 structure that can be used in systems that require up to Performance Level PLd per ISO 13849-1:2006. This circuit executes a Stop Category 0.

See publication [937TH-WD001](#) for more safeguarding examples with the galvanic isolator.

**Figure 29 - Hazardous Location**

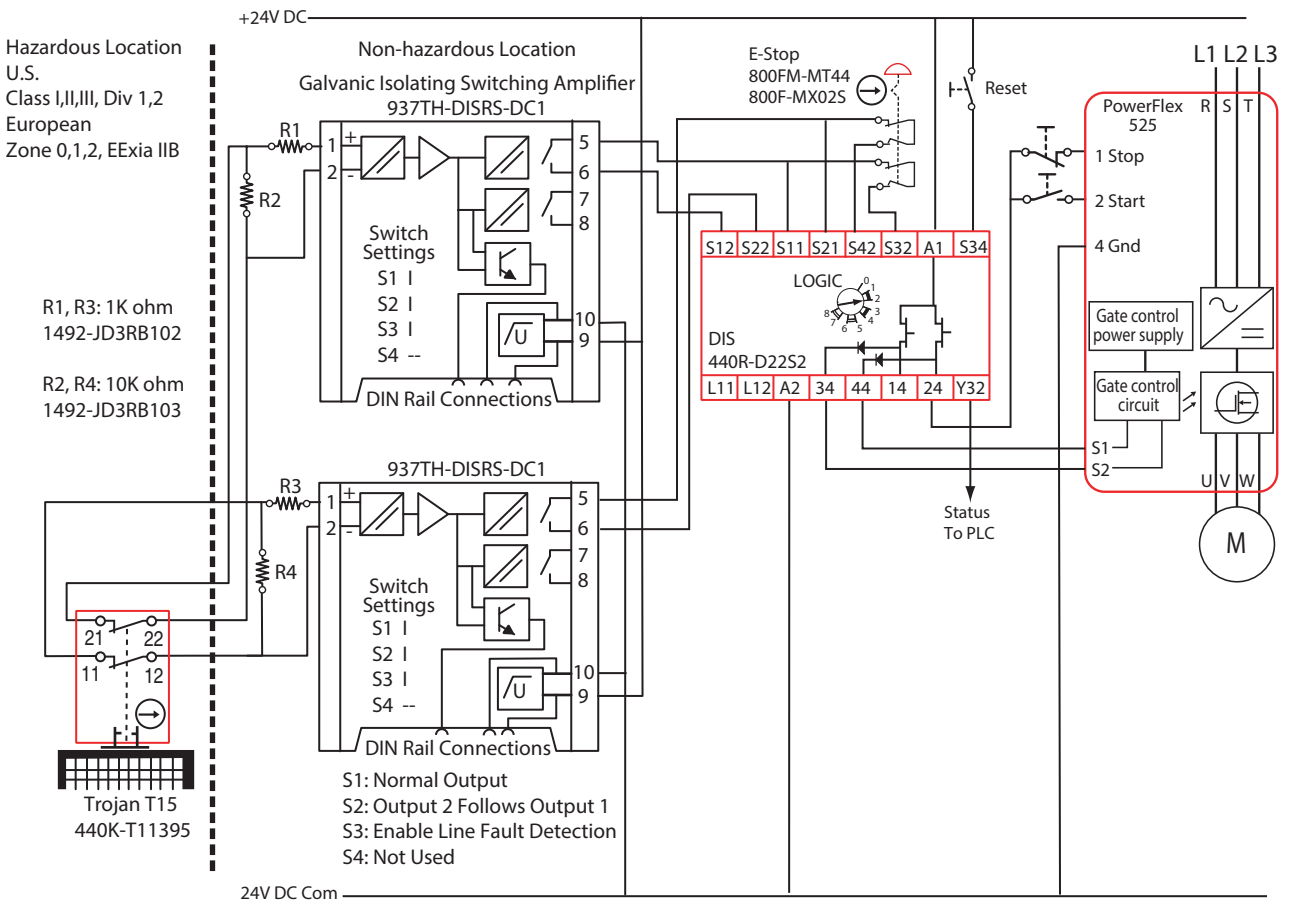

## Hazardous Location

### Circuit Components

- Bulletin 440F MatGuard safety mats
- Bulletin 800F E-stops
- Bulletin 937TH isolator
- DIS safety relay
- PowerFlex 525 drive

### Circuit Status

The DIS safety relay logic is set to 2: [(IN1 AND IN2) OR L12] with monitored reset. The safety mat is connected to input 1 of the DIS (S12 and S22) through the galvanic isolator. The E-stop is connected to input 2 of the DIS safety relay (S32 and S42). The gate is closed and the E-stop is released. The DIS safety outputs are off. The PowerFlex 525 drive is powered but disabled. The motor is off.

### Operating Principle

The galvanic isolator limits energy to the MatGuard, which is considered a simple apparatus in the hazardous location. The DIS safety relay checks the outputs of the galvanic isolator upon power-up and each time the mat/E-stop is actuated.

**STARTING:** Press the Reset button to turn the DIS safety outputs (14, 24, 34, 44 and L11) ON. This action enables the PowerFlex 525 drive. Press the Start button to turn the motor ON.

**STOPPING:** Normal production stops are performed by pressing the Stop button. Stepping on the safety mat or pressing the E-stop initiates a safety stop; the motor coasts to a stop.

### Fault Detection

The DIP switch setting of the galvanic isolator allows for open and short-circuit detection of the safety mat. Since the Bulletin 937TH isolator has a hardware fault tolerance of zero, two are used to achieve single fault tolerance. The isolator DIP switches must be set for Line Fault Detection (I) and inverted (II) output. The Bulletin 1492 resistors are required to detect line faults. These resistors must be located as close as possible to the safety mat.

### Ratings

The safety mat initiates a safety function that meets the safety performance requirements of SIL CL 2 per IEC 62061:2005 and has a Category 3 structure that can be used in systems that require up to Performance Level PLd, per ISO 13849-1:2006.

The E-stop initiates a safety function that meets the safety performance requirements of SIL CL 2 per IEC 62061:2005 and has a Category 3 structure that can be used in systems that require up to Performance Level PLd, per ISO 13849-1:2006. This circuit executes a Stop Category 0.

See publication [937TH-WD001](#) for more safeguarding examples with the galvanic isolator.



**Figure 30 - Hazardous Location**

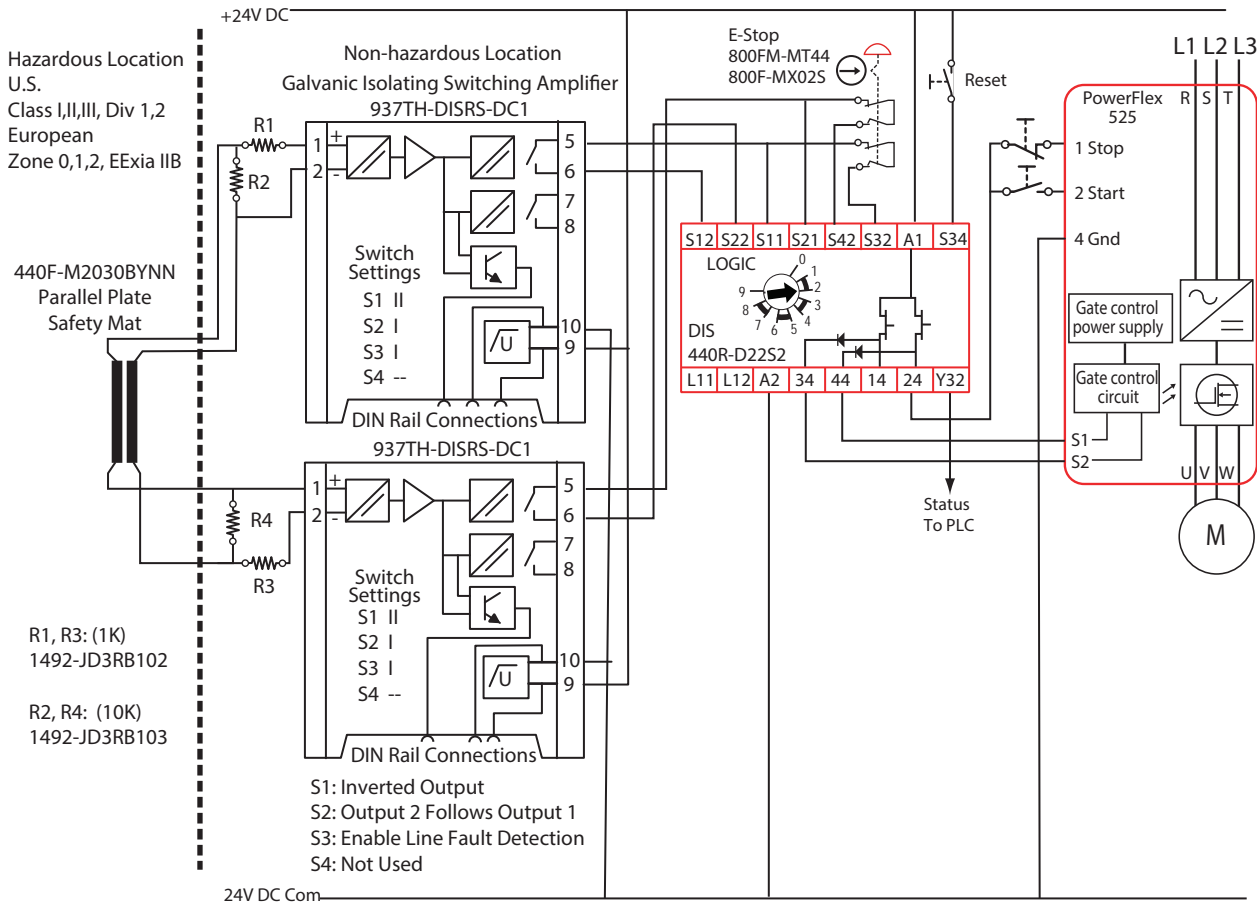

## Hazardous Location

### Circuit Components

- Safedge™ pressure sensitive sensing edge
- Bulletin 440F MatGuard safety mats
- Bulletin 800F E-stops
- Bulletin 937TH isolator
- DIS safety relay
- PowerFlex 525 drive

### Circuit Status

The DIS safety relay logic is set to 2: [(IN1 AND IN2) OR L12] with monitored reset. The sensing edge is connected to input 1 of the DIS (S12 and S22) through the galvanic isolator. The E-stop is connected to input 2 of the DIS safety relay (S32 and S42). The gate is closed and the E-stop is released. The DIS safety outputs are off. The PowerFlex 525 drive is powered but disabled. The motor is off.

### Operating Principle

The galvanic isolator limits energy to the sensing edge, which is considered a simple apparatus in the hazardous location. The DIS safety relay checks the outputs of the galvanic isolator upon power-up and each time the safety edge/E-stop is actuated.

**STARTING:** Press the Reset button to turn the DIS safety outputs (14, 24, 34, 44 and L11) ON. This action enables the PowerFlex 525 drive. Press the Start button to turn the motor ON.

**STOPPING:** Normal production stops are performed by pressing the Stop button. Stepping on the sensing edge or pressing the E-stop initiates a safety stop; the motor coasts to a stop.

### Fault Detection

The DIP switch setting of the galvanic isolator allows for open and short-circuit detection of the safety edge. Since the Bulletin 937TH isolator has a hardware fault tolerance of zero, two are used to achieve single fault tolerance. The isolator DIP switches must be set for Line Fault Detection (I) and inverted (II) output. The 1492 resistors are required to detect line faults. These resistors must be located as close as possible to the safety edge.

### Ratings

The sensing edge initiates a safety function that meets the safety performance requirements of SIL CL 2 per IEC 62061:2005 and has a Category 3 structure that can be used in systems that require up to Performance Level PLd, per ISO 13849-1:2006.

The E-stop initiates a safety function that meets the safety performance requirements of SIL CL 2 per IEC 62061:2005 and has a Category 3 structure that can be used in systems that require up to Performance Level PLd, per ISO 13849-1:2006. This circuit executes a Stop Category 0.

See publication [937TH-WD001](#) for more safeguarding examples with the galvanic isolator.

**Figure 31 - Hazardous Location**

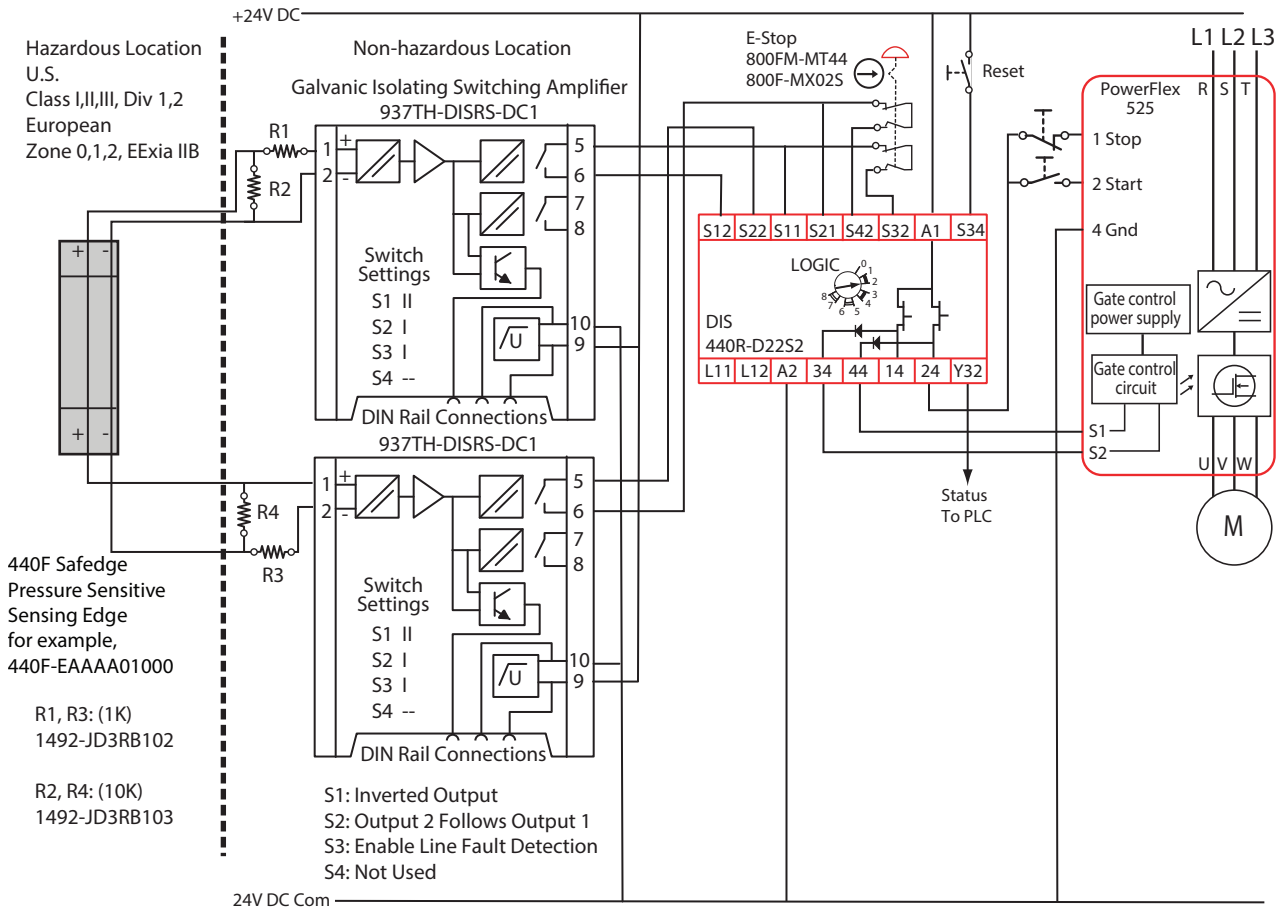

## PowerFlex Drive - Multiple Gate Access

### Circuit Components

- Trojan 5 GD2 tongue interlock switch
- MT-GD2 latch release
- DIS safety relay
- PowerFlex 70 drive with DriveGuard

### Circuit Status

One of the gates is open. The safety outputs of the DIS safety relay are de-energized. The PowerFlex with DriveGuard is de-energized and not enabled. The motor is off. The DIS safety relay has a Logic setting of 6: [(IN1 AND IN2) OR L12] with automatic reset.

### Operating Principle

**STARTING:** When the last gate closes, the safety outputs of the DIS safety relay close and apply power to the Drive Enable circuit, Safe Torque Off option, and Start/Stop buttons. Pressing the Start and Stop buttons turns the motor on and off. Parameters set within the PowerFlex drive control the motor.

**STOPPING:** Opening any of the guard doors causes the DIS safety outputs to de-energize. This action removes power to the PowerFlex Enable, Safe Torque Off, Start, and Stop circuits. The motor performs a coast-to-stop.

### Fault Detection

Upon power-up, the PowerFlex drive and DIS safety relay perform internal checks. The DIS safety relay then looks for dual signals from the gate interlocks. With the gates closed, the DIS safety relay checks the wiring of the drive Safe Torque Off option. If closed, then the DIS safety relay energizes its outputs and the motor can be started. A single open circuit fault at the gate interlocks is detected immediately, and the motor coasts to a stop. A cross fault (channel 1 to channel 2) at the gate interlocks is detected immediately. The DIS safety relay is rated for Category 4 and does not lose the safety function due to an accumulation of faults. The PowerFlex 70 DriveGuard is rated at Category 3, as it performs the safety function in the presence of a single internal fault.

### Ratings

The gate interlocks initiate a safety function that meets the safety performance requirements of SIL CL 2 per IEC 62061:2005 and has a Category 3 structure that can be used in systems that require Performance Levels up to PLd per ISO 13849-1:2006. This circuit executes a Stop Category 0.

**Figure 32 - PowerFlex Drive - Multiple Gate Access**

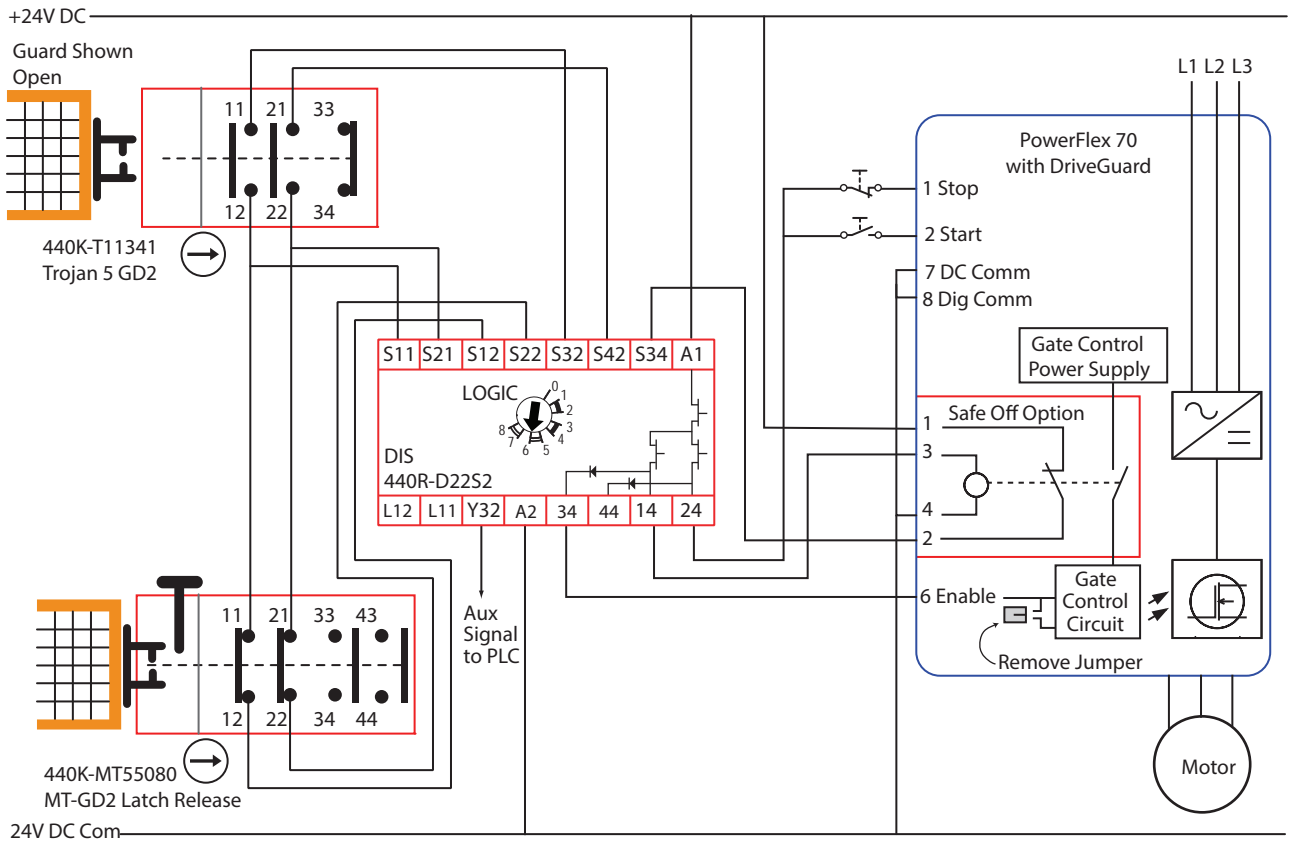

## Multiple PowerFlex Drives

### Circuit Components

- Trojan 5 GD2 tongue interlock switch
- DIS safety relay
- PowerFlex 70 drive with DriveGuard

### Circuit Status

The safety gate is open. The DIS safety outputs (14, 24, 34, and 44) are off. The Enable and Safe Torque Off option on both PowerFlex drives are off. Auxiliary signals from the Trojan 5 GD2 switch (33/34) and the DIS safety relay (Y32) inform the PLC that the safety system is OFF. The motors of both drives are off. The Logic setting of the DIS safety relay is set to 5: [(IN1 OR IN2) OR L12] with automatic reset.

This circuit is intended to show that multiple drives can be connected in parallel. The number of drives that can be connected in parallel is dependent on:

- The load (the Safe Torque Off option plus the enable of each drive)
- Appropriate derating to help prevent early wear out of the DIS safety relay solid-state outputs
- The application requirements (for example, zoning)
- The risk assessment (for example, some drives require separate safety systems).

### Operating Principle

**STARTING:** Upon closing the gate, the Trojan 5 GD2 switch closes the safety inputs of the DIS safety relay (S32 and S42) and opens the signal to the PLC. The safety outputs of the DIS safety relay close and enable both PowerFlex drives. The auxiliary signal of the DIS safety relay opens. The PLC compares the gate and safety relay aux signals. When both signals are open, the PLC knows that the safety system is ready. The PLC can now start and control the drives over the DeviceNet™ network. The PLC must verify that the drives are not started upon the closing of the gate; a separate, intentional action must initiate the motor movement (not shown [Figure 33](#)).

**STOPPING:** The PLC performs normal stopping. If the gate is opened, the input signals to the DIS safety relay open. The DIS safety relay opens its safety outputs that disable all drives that are connected to them via the Safe Torque Off option. The drives perform an immediate coast-to-stop.

### Fault Detection

Upon power-up, the DIS safety relay performs internal checks. The DIS safety relay then looks for dual signals from the Trojan5-GD2 switch. If only one signal is present, or a cross fault exists, the DIS safety relay assumes that a fault is present and does not energize its safety outputs. With the gate closed, the DIS safety relay checks the S34 monitoring circuit. If the Safe Torque Off options are de-energized, the DIS safety relay assumes that the drives are off and are ready to be enabled. The DIS safety relay energizes its safety outputs. If the monitoring circuit remains open, the DIS safety relay assumes that a fault is present and not allow its safety outputs to energize. Single-point failures that are related to the tongue interlock are excluded if actuator speed, alignment and mechanical stops meet installation instruction requirements, and a periodic proof test confirms proper operation.

## Ratings

The Trojan 5-GD2 gate interlock initiates a safety function that meets the safety performance requirements of SIL CL 2 per IEC 62061:2005 and has a Category 3 structure that can be used in systems that require Performance Levels up to PLd per ISO 13849-1:2006. This circuit executes a Stop Category 0.

**Figure 33 - Multiple PowerFlex Drives**

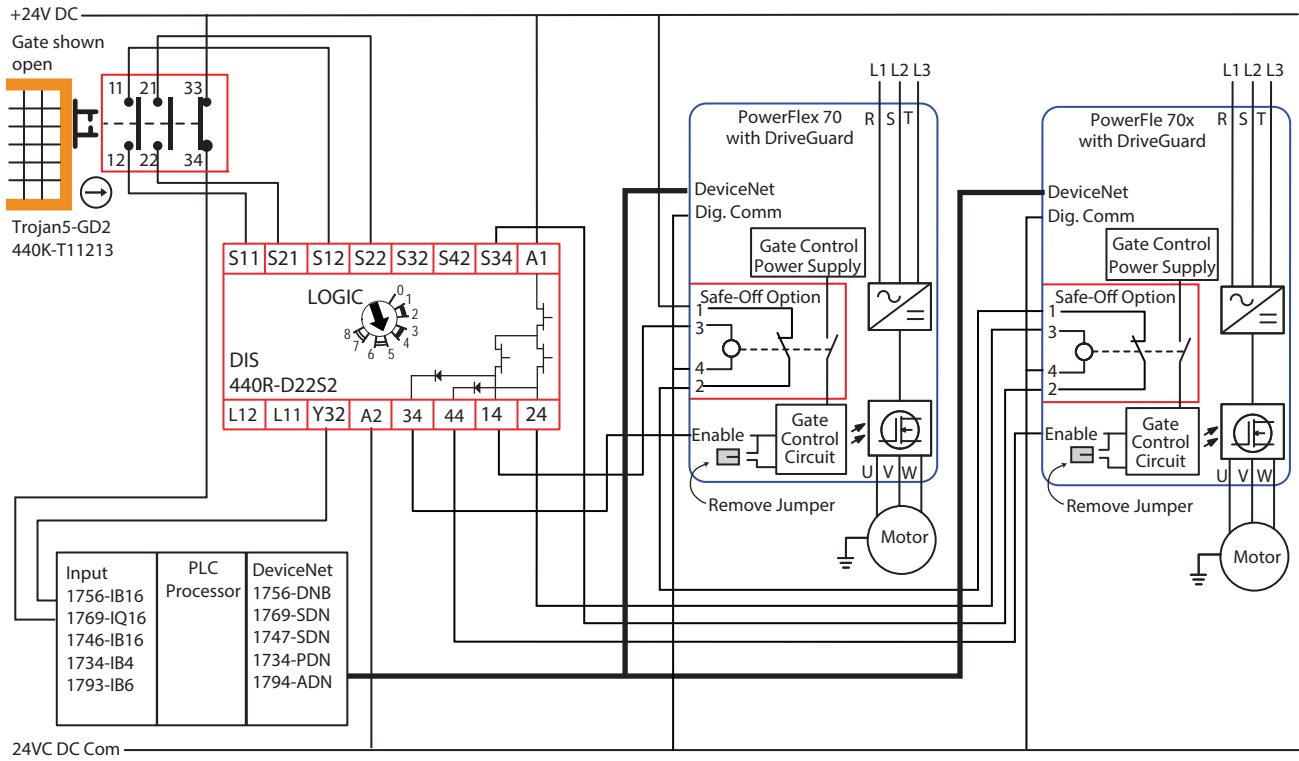

## Micro 400 Light Curtain

### Circuit Components

- Micro 400 light curtain
- MSR41 controller module
- Bulletin 800F E-stop
- DIS safety relay
- Bulletin 100S contactor

### Circuit Status

The light curtain is clear and the E-stop is released. The MSR41 controller outputs are energized. The safety outputs of the DIS safety relay are OFF. The motor is off. The DIS safety relay is ready for reset. The DIS safety relay has a Logic setting of 2: [(IN1 AND IN2) OR L12] with monitored manual reset.

### Operating Principle

**STARTING:** Press the Reset button to turn the DIS safety outputs ON. Press the Start button to turn the motor ON. The Start /Stop circuit operates only K2, as a planned maintenance feature. K1 does not switch on motor current, but it can switch off the motor current when a demand is placed on the safety system.

**STOPPING:** Normal production stops are performed by pressing the Stop button. A safety stop can be accomplished by obstructing the light curtain or by pressing the E-stop. The motor performs a coast-to-stop.

### Fault Detection

Upon power-up, the safety devices perform internal checks. The OSSD outputs of the MSR41 controller are pulse tested to check for cross faults. The E-stop signals are pulse tested to check for cross faults. The mechanically linked contacts of the Bulletin 100S contactor verify that the contactors are off after a demand is placed on the safety system.

### Ratings

The safety function meets the safety performance requirements of SIL CL 3 per IEC 62061:2005 and has a Category 4 structure that can be used in systems that require Performance Levels up to PLe per ISO 13849-1:2006. This circuit executes a Stop Category 0.



**Figure 34 - Micro 400 Light Curtain**

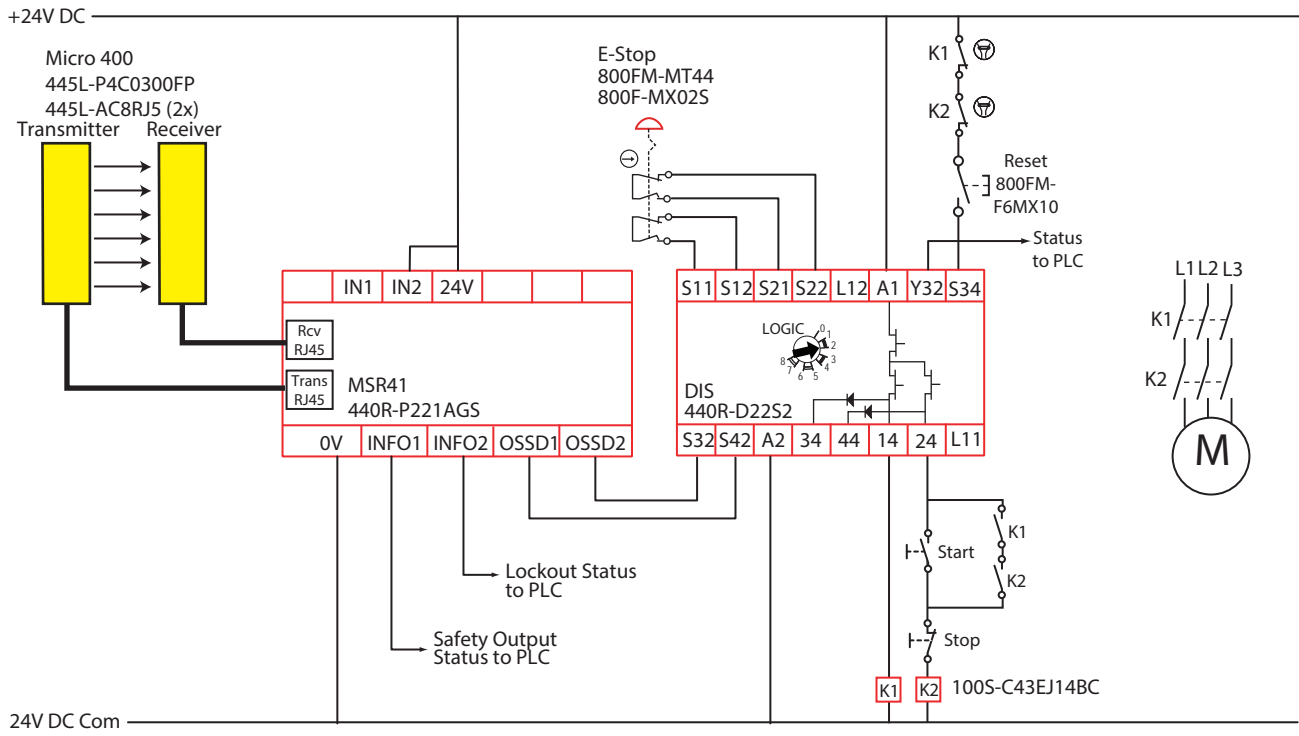

## Micro 400 Light Curtain

### Circuit Components

- Micro 400 light curtain
- SensaGuard non-contact interlock switch
- Bulletin 800F E-stop
- MSR42 controller module
- DIS and DI safety relays
- Bulletin 100S contactor

### Circuit Status

The light curtain is clear; the SensaGuard switch is closed; and the E-stop is released. The MSR42 module and DIS safety outputs are energized. The safety outputs of the DI safety relay are OFF. The motor is off. The DI safety relay is ready for reset. The DIS safety relay has a Logic setting of 6:  $[(IN1 \text{ AND } IN2) \text{ OR } L12]$  with automatic reset. When the machine is in a specified position, as detected by the SensaGuard switch, the light curtain is bypassed. When the machine moves away from the specified position, the SensaGuard switch turns OFF and the Micro 400 light curtain becomes active. The DI safety relay has a logic setting of 3:  $[(IN1 \text{ OR } IN2) \text{ AND } L12]$  with monitored manual reset, which makes the E-stop always effective (and the SensaGuard switch or Micro 400 light curtain).

### Operating Principle

**STARTING:** Press the Reset button to turn the DI safety outputs ON. Press the Start button to turn the motor ON. The Start /Stop circuit operates only K2, as a planned maintenance feature. K1 does not switch on motor current, but it can switch off the motor current when a demand is placed on the safety system.

**STOPPING:** Normal production stops are performed by pressing the Stop button. A safety stop can be accomplished by obstructing the light curtain when the SensaGuard switch does not detect the machine position or pressing the E-stop. The motor performs a coast-to-stop.

### Fault Detection

Upon power-up, the safety devices perform internal checks. The OSSD outputs of the MSR42 module are pulse tested to check for cross faults. The OSSD outputs of the SensaGuard switch are pulse tested to check for cross faults. The single wire safety signal (L11 to L12) tests for faults to power and ground when active. The E-stop signals are pulse tested to check for cross faults. The mechanically linked contacts of the Bulletin 100S contactor verify that the contactors are off after a demand is placed on the safety system.

### Ratings

The safety function meets the safety performance requirements of SIL CL 3 per IEC 62061:2005 and has a Category 4 structure that can be used in systems that require Performance Levels up to PLe per ISO 13849-1:2006. This circuit executes a Stop Category 0.

**Figure 35 - Micro 400 Light Curtain**

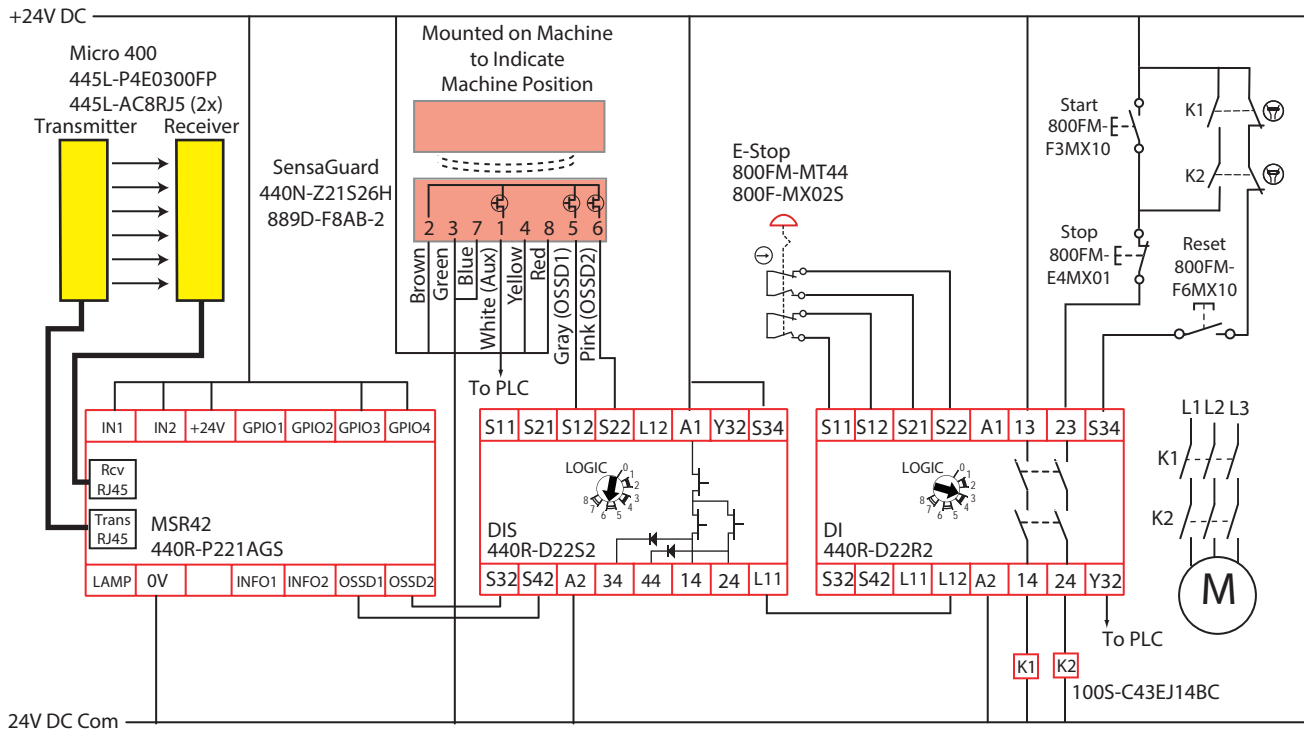

## Cat 1 Stop with Guard Locking Interlock and Proximity Sensors

### Circuit Components

- TLS3-GD2 guard locking switch
- Bulletin 872C proximity sensors
- Guard locking proximity (GLP) safety relay
- PowerFlex 70 drive

### Circuit Status

The gate is closed and locked. The motor is off. The GLP safety relay is ready for reset. The GLP safety relay has a Logic setting of 1: (Category 1 Stop with Logic IN OFF), a safely-limited speed (SLS1) setting of 0 (0.5 Hz, 10.1 seconds) and a maximum speed setting (SLS2/Time) of 2 (20 Hz). The safety outputs (S11 & S21), the single wire safety output (L11), and the auxiliary output (Y32) are OFF.

**TIP** Start the GLP logic configuration from "0" to configure X14 and X24 for use as safety outputs.

### Operating Principle

**STARTING:** Press the Reset button to lock the gate and turn the GLP safety outputs ON. Press the Start button to turn the motor ON.

**STOPPING:** Normal production stops are performed by pressing the Stop button. Access through the safety gate is initiated by pressing the Gate Unlock Request button. The Y32 output of the GLP safety relay turns OFF and initiates a stop command to the drive. When the proximity sensors detect speed below the safely-limited speed for 10.1 seconds, the gate unlocks and the safety outputs turn OFF. The PowerFlex drive goes to a Safe Torque Off state.

### Fault Detection

Upon power-up, the safety devices perform internal checks. The TLS3 interlock switch has dual-channel signals but does not check for cross faults. The GLP safety outputs are pulse tested to check for faults. The GLP safety relay uses redundant proximity sensors that must be mounted on independent fixtures. The PowerFlex 70 requires two safety signals to enable the drive.

**OVERSPEED:** If the proximity sensors detect a speed above the maximum speed (20 Hz), the auxiliary output (Y32), the safety outputs (X14 & X24), and the single wire safety output (L11) turn off. The PWR/Fault indicator flashes at a 3X rate. When the speed drops below the max speed limit, press the Reset button to clear the fault and energize the safety outputs.

### Ratings

The safety function meets the safety performance requirements of SIL CL 2 per IEC 62061:2005 and has a Category 3 structure that can be used in systems that require Performance Levels up to PLd per ISO 13849-1:2006. This circuit executes a Stop Category 1.

**Figure 36 - Cat 1 Stop with Guard Locking Interlock and Proximity Sensors**

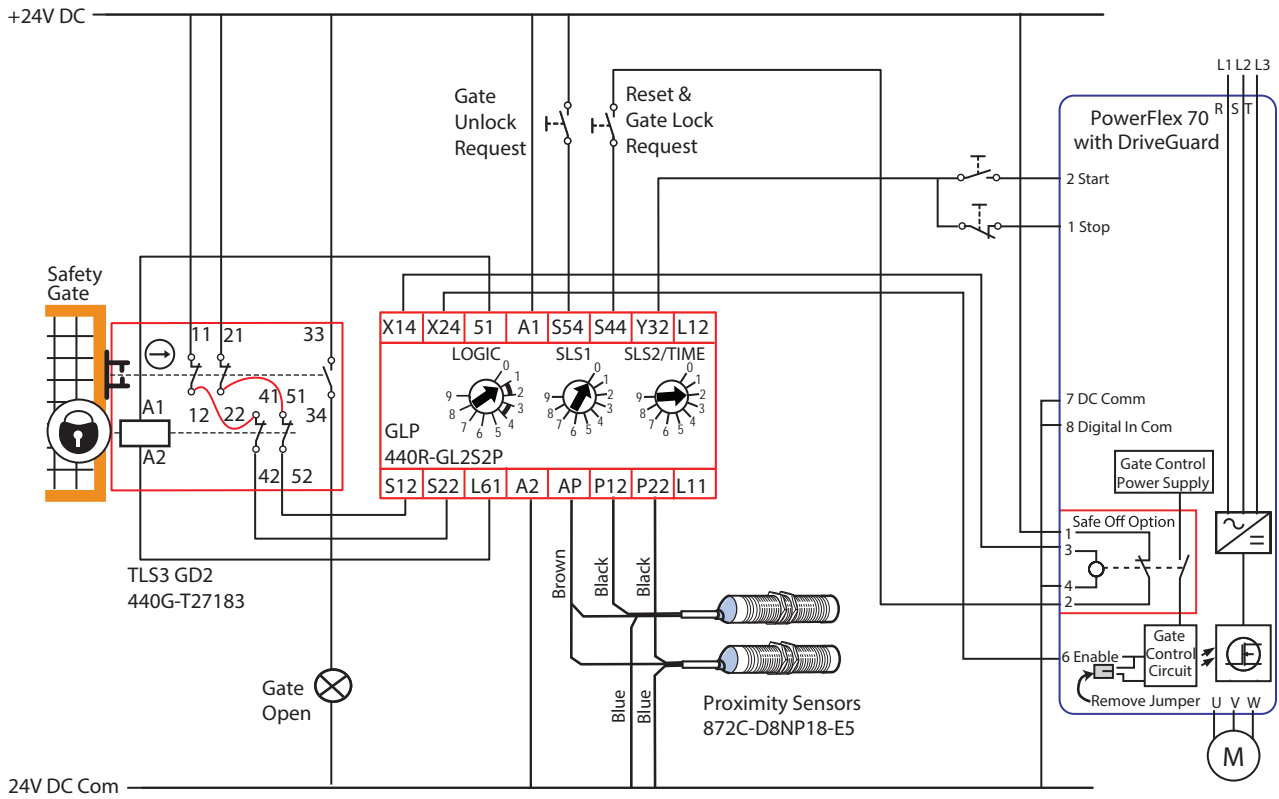

## Stop Motion with Guard Locking by PLC

### Circuit Components

- TLS-ZR guard locking switch
- Bulletin 872C proximity sensors
- Guard locking proximity (GLP) safety relay
- Bulletin 1734 POINT Guard I/O™

### Circuit Status

This example shows how to use the GLP safety relay to measure the speed of the machine and allow a safety PLC to control the locking function of the guard locking interlock.

The gate is closed and locked. The GLP safety relay is ready for reset. The GLP safety relay has a Logic setting of 1: (Category 1 Stop with Logic IN OFF), a safely-limited speed (SLS1) setting of 0 (0.5 Hz, 10.1 seconds) and a maximum speed setting (SLS2/Time) of 2 (20 Hz). The safety outputs (X14 & X24), the single wire safety output (L11), and the auxiliary output (Y32) are OFF.

**TIP** Start the GLP logic configuration from “0” to configure X14 and X24 for use as safety outputs.

### Operating Principle

**STARTING:** Press the Lock and Reset Request button. The PLC locks the safety gate, if not already locked, and sends the reset signal to terminal S44 of the GLP safety relay. The safety outputs at X14 and X24 of the GLP safety relay turn ON. The safety PLC uses the X14 and X24 signals to allow the execution of a safety function.

**STOPPING:** Press the Unlock Request button. The safety PLC executes a stop function and sends an unlock signal to terminal S54 of the GLP safety relay. When the proximity sensors detect speed below the SLS1 setting for 10.1 seconds, the safety outputs X14 and X24 turn OFF. The safety PLC uses the X14 and X24 signals to help prevent the restart of the hazard.

### Fault Detection

Upon power-up, the safety devices perform internal checks. The GLP and TLS-ZR devices have dual channel OSSD outputs that check for fault conditions. The GLP safety outputs are pulse tested to check for faults. The GLP safety relay uses redundant proximity sensors that must be mounted on independent fixtures. The POINT Guard I/O blocks are safety rated and a GuardLogix® safety PLC must control them.

**OVERSPEED:** If the proximity sensors detect a speed above the maximum speed (20 Hz), the safety outputs at terminals X14 & X24 turn off. The PWR/Fault indicator flashes at a 3X rate. When the speed drops below the max speed limit, press the Reset button to clear the fault and re-energize the safety outputs.

### Ratings

The safety function meets the safety performance requirements of SIL CL 2 per IEC 62061:2005 and has a Category 3 structure that can be used in systems that require Performance Levels up to PLd per ISO 13849-1:2006. This circuit executes a Stop Category 1.

**Figure 37 - Stop Motion with Guard Locking by PLC**

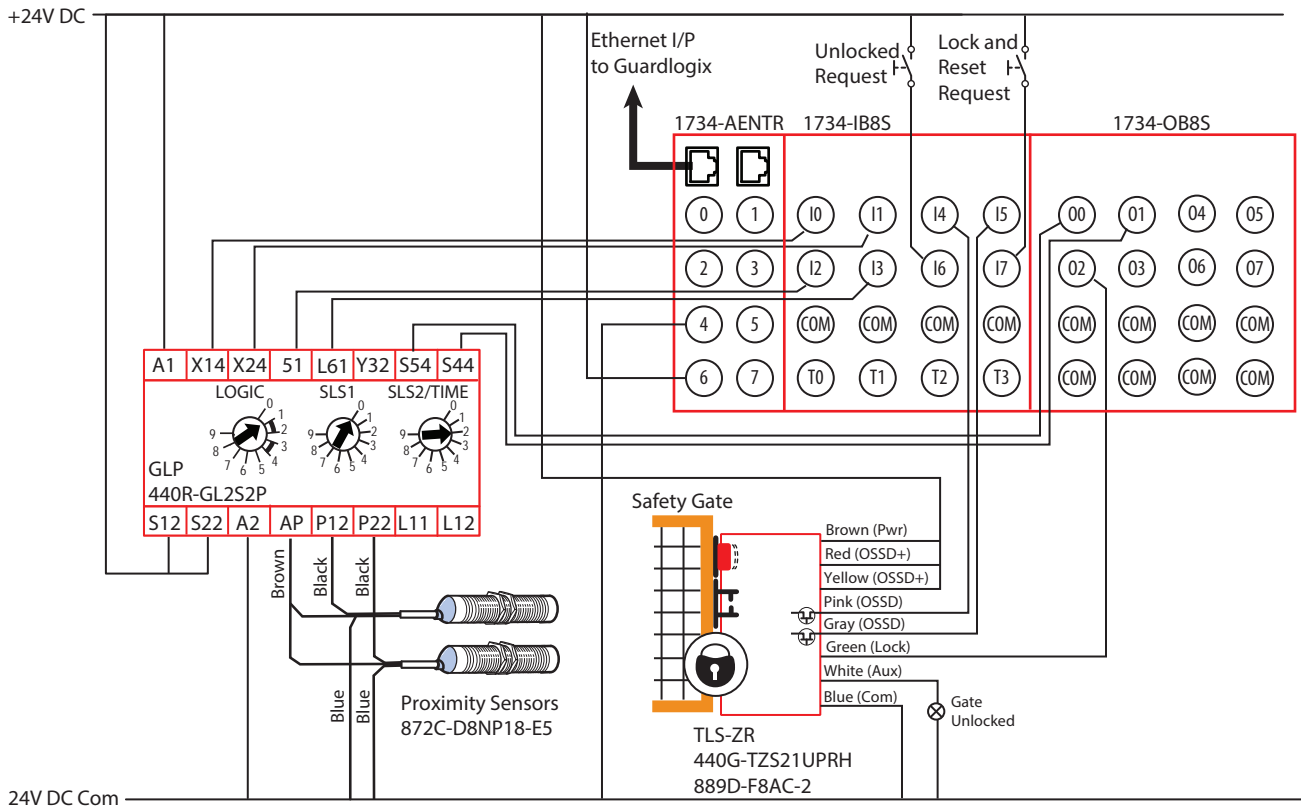

## Guard Locking Interlock with High Current Solenoid

### Circuit Components

- Bulletin 440G-MT solenoid guard locking switch
- Bulletin 871TM proximity sensors
- GLP and EM safety relays
- PowerFlex 525 drive

### Circuit Status

The gate is closed and locked. The GLP safety relay has a Logic setting of 1: (Category 1 Stop with Logic IN OFF), a safely-limited speed (SLS1) setting of 0 (0.5 Hz) and a Maximum (SLS2) speed setting of 0 (unlimited). The proximity sensors detect speed below 0.5 Hz. The single wire safety output (L11) and the auxiliary output (Y32) are OFF. Terminals X14 & X24 are configured for pulse testing.

**TIP** Start the GLP configuration from “9” to configure X14 and X24 for use as pulse testing.

**TIP** Since the 440G-MT solenoid switch requires 540 mA, an interposing relay (CR1) must be used. A diode must be connected across the solenoid of CR1 as shown in [Figure 38](#).

### Operating Principle

**STARTING:** Press the Lock and Reset Request. The Y32 output and SWS output at L11 turn ON, and the EM safety relay is energized. The EM safety relay energizes S1 and S2, which enable the PowerFlex 525 drive. Press the Start button to start the motor.

**STOPPING:** Normal production stops are performed by pressing the Stop button. To gain access through the safety gate, press the Gate Unlock Request button. The Y32 output turns OFF and the PowerFlex 525 drive decelerates. When the proximity sensors detect speed below 0.5 Hz for 10.1 seconds, the GLP safety relay energizes terminals 51 and L61, which unlocks the 440G-MT switch.

**OVERSPEED:** Overspeed is not checked because SLS2 is set to 0.

### Fault Detection

Upon power-up, the safety devices perform internal checks. The 440G-MT switch has dual-channel contacts and is tested for short circuits by pulse testing from the GLP safety relay. The GLP safety relay uses redundant proximity sensors that must be mounted on independent fixtures.

If the Gate Lock Request is pressed while the gate is open, the GLP PWR/Fault indicator flashes red three times. Close the gate; press the Gate Unlock Request and then press the Gate Lock Request to clear the fault.

If the speed exceeds 0.5 Hz while the gate is unlocked, the GLP PWR/Fault indicator flashes red seven times. Reduce the speed and cycle the power to the GLP safety relay to clear the fault.



## Ratings

The safety function meets the safety performance requirements of SIL CL 2 per IEC 62061:2005 and has a Category 3 structure that can be used in systems that require Performance Levels up to PLd per ISO 13849-1:2006. The safety function performs a Stop Category 1.

**Figure 38 - Guard Locking Interlock with High Current Solenoid**

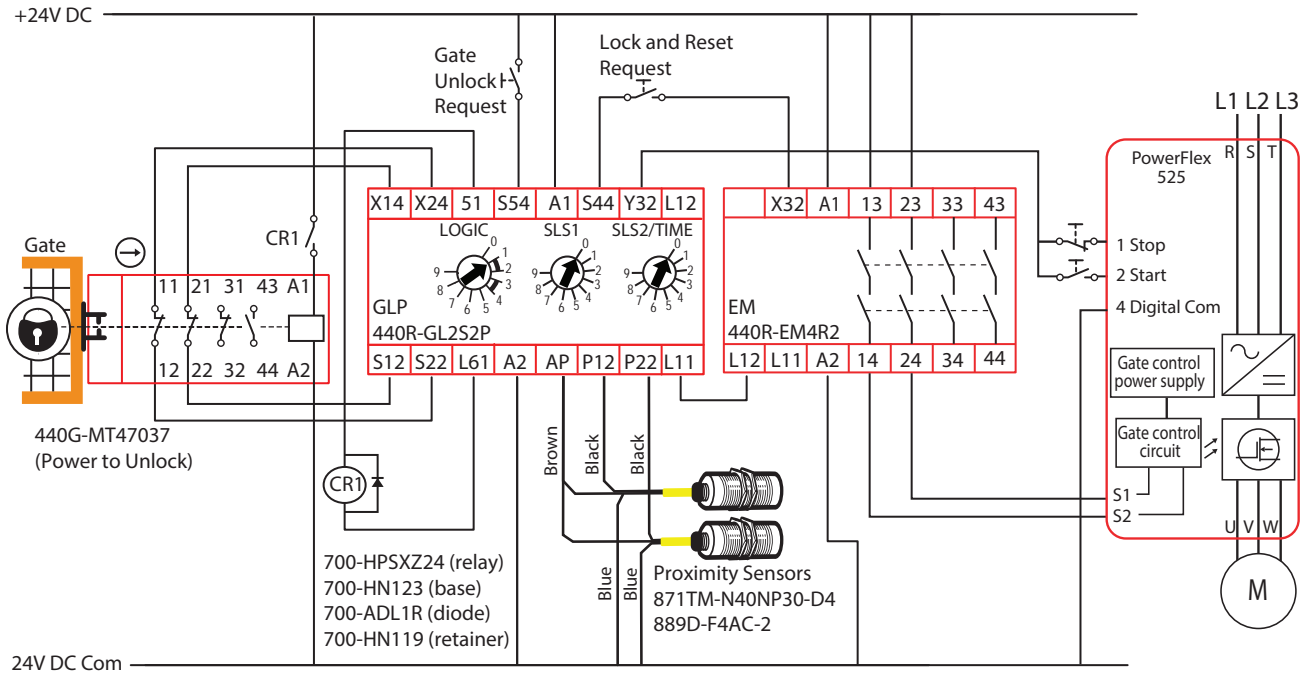

## Stop Category 1 with Logic IN, Guard Locking, and Proximity Sensors

### Circuit Components

- Bulletin 440G-LZ guard locking switch
- Bulletin 871TM proximity sensors
- Bulletin 800F E-stops
- SI and GLP safety relays
- PowerFlex 70 drive

### Circuit Status

The E-stop is released. The safety gate is closed and locked. The SI and GLP safety relay are ready for reset. The GLP safety relay has a Logic setting of 2: (Stop Category 1 with Logic IN), a safely-limited speed (SLS1) setting of 1 (1 Hz, 5.05 seconds) and a maximum speed setting (SLS2/Time) of 5 (200 Hz). The proximity sensors are rated for 400 Hz. The K1 and K2 contactors are off. The GLP safety outputs (X14 and X24), the single wire safety output (L11), and the auxiliary output (Y32) are OFF. The motor is off.

**TIP** Start the GLP logic configuration from "0" to configure X14 and X24 for use as safety outputs.

### Operating Principle

This example is a cascaded safety system with a GSR single wire safety connection (L11 to L12). Pressing the E-stop initiates a safety stop command that turns off the contactors and the drive. However, pressing the Gate Unlock Request button turns off the motor and allows access to the safety gate while leaving K1 and K2 energized.

**STARTING:** Press the Reset button on the SI to energize K1 and K2 and to enable the GLP safety relay through the single wire safety connection (L11 to L12). Then press the Reset and Gate Lock Request button to lock the gate and turn the GLP safety outputs ON. Press the Start button to turn the motor ON.

**STOPPING:** Initiate a safety stop by taking either of the following actions:

- Press the E-stop, which turns off K1 and K2 and initiates the Gate Unlock Request function in the GLP safety relay.
- Press the Gate Unlock Request, which leaves K1 and K2 energized and initiates a Cat 1 stop to the PF70 drive.

When the GLP safety relay initiates a stop, the Y32 output turns OFF and initiates a stop command to the drive. When the proximity sensors detect speed below the safely-limited speed for 5.05 seconds, the gate unlocks and the safety outputs turn OFF. The PowerFlex drive goes to a Safe Torque Off state.

### Fault Detection

Upon power-up, the safety devices perform internal checks. The 440G-LZ switch and GLP safety relay have dual channel pulse tested outputs that check for faults. The GLP safety relay uses redundant proximity sensors that must be mounted on independent fixtures. The PowerFlex 70 drive requires two safety signals to enable the drive.

**OVERSPEED:** If the proximity sensors detect a speed above the maximum speed (200 Hz), the auxiliary output (Y32), the safety outputs (X14 & X24), and the single wire safety output (L11) turn off. The PWR/Fault indicator flashes at a 3X rate. When the speed drops below the max speed limit, press the Reset button to clear the fault and energize the safety outputs.

### Ratings

The safety function meets the safety performance requirements of SIL CL 2 per IEC 62061:2005 and has a Category 3 structure that can be used in systems that require Performance Levels up to PLd per ISO 13849-1:2006. This circuit executes a Stop Category 1.

**Figure 39 - Stop Cat 1 with Logic IN, Guard Locking, and Proximity Sensors**

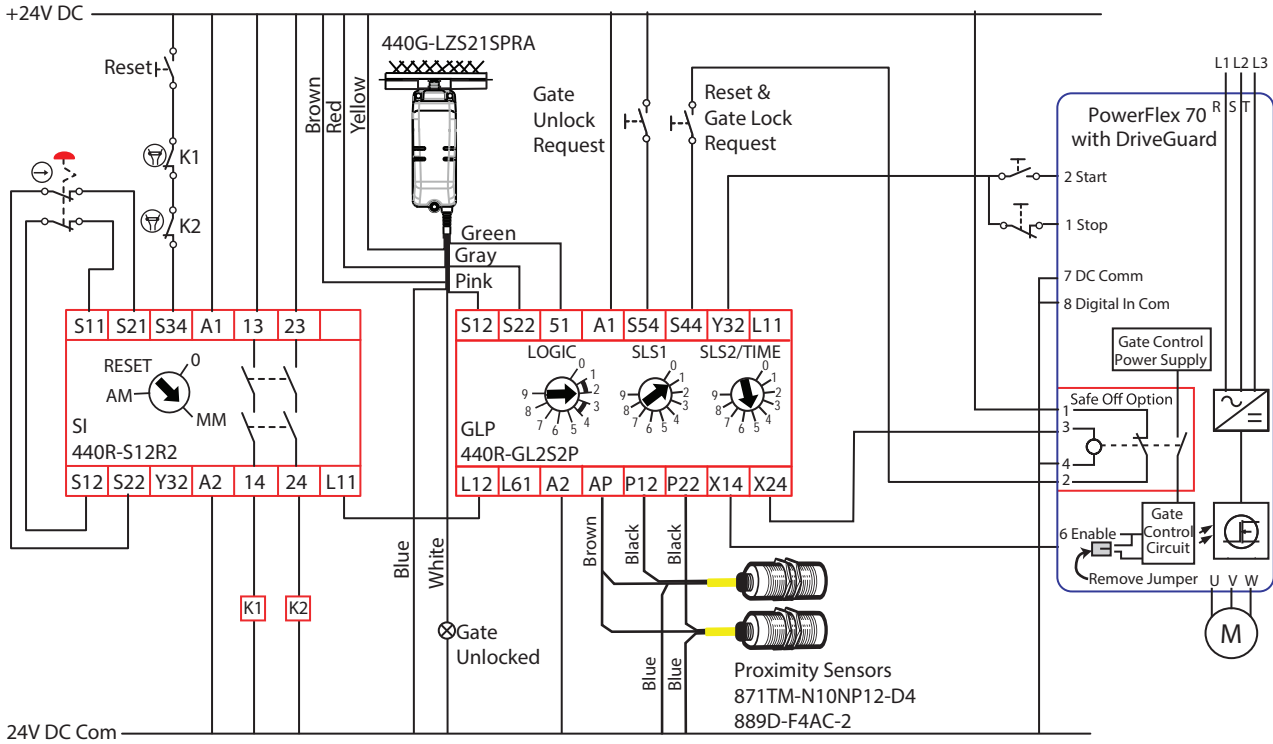

## Safely-limited Speed with Guard Locking Interlock and Proximity Sensors

### Circuit Components

- TLSZR-GD2 guard locking switch
- Bulletin 871TM proximity sensors
- GLP safety relays
- Kinetix 300 drive

### Circuit Status

The gate is closed and locked. The motor is off. The GLP safety relay is ready for reset. The GLP safety relay has a Logic setting of 3: (Safely-limited speed with Logic IN OFF), a safely-limited speed (SLS1) setting of 9 (10 Hz, 0.6 seconds) and a maximum (SLS2/Time) speed setting of 0 (no checking for max frequency). The safety outputs (X14 & X24), the single wire safety output (L11), and the auxiliary output (Y32) are OFF.

**TIP** Start the GLP logic configuration from “0” to configure X14 and X24 for use as safety outputs.

### Operating Principle

**STARTING:** Press the Reset and Gate Lock Request button to turn the GLP safety outputs and enable the Kinetix 300 drive. Press the Start button to turn the motor ON.

**STOPPING:** Normal production stops are performed by pressing the Stop button. Access through the safety gate is initiated by pressing the Gate Unlock Request button. The Y32 output of the GLP safety relay turns ON and commands the Kinetix drive to bring the motor to a safely-limited speed (less than 10 Hz). When the proximity sensors detect speed below 10 Hz for 0.6 seconds, the gate unlocks. The operator can enter the machine cell, as the motor continues to run at the safe slow speed. After leaving the cell and closing the gate, press the Reset and Gate Lock Request button to lock the gate and return the machine to production speeds.

### Fault Detection

Upon power-up, the safety devices perform internal checks. The TLSZR switch has OSSD outputs and checks for cross faults. The GLP safety outputs are pulse tested to check for faults. The GLP safety relay uses redundant proximity sensors that must be mounted on independent fixtures. The Kinetix 300 drive requires two safety signals to enable the drive.

**OVERSPEED:** If the gate is unlocked and the motor speed increases beyond the safely-limited speed, the GLP safety relay turns its safety outputs OFF and the motor coasts to a stop.

### Ratings

The safety function meets the safety performance requirements of SIL CL 2 per IEC 62061:2005 and has a Category 3 structure that can be used in systems that require Performance Levels up to PLd per ISO 13849-1:2006. This circuit executes Stop Category 0 for fault conditions.

**Figure 40 - Safely-limited Speed with Guard Locking Interlock and Proximity Sensors**

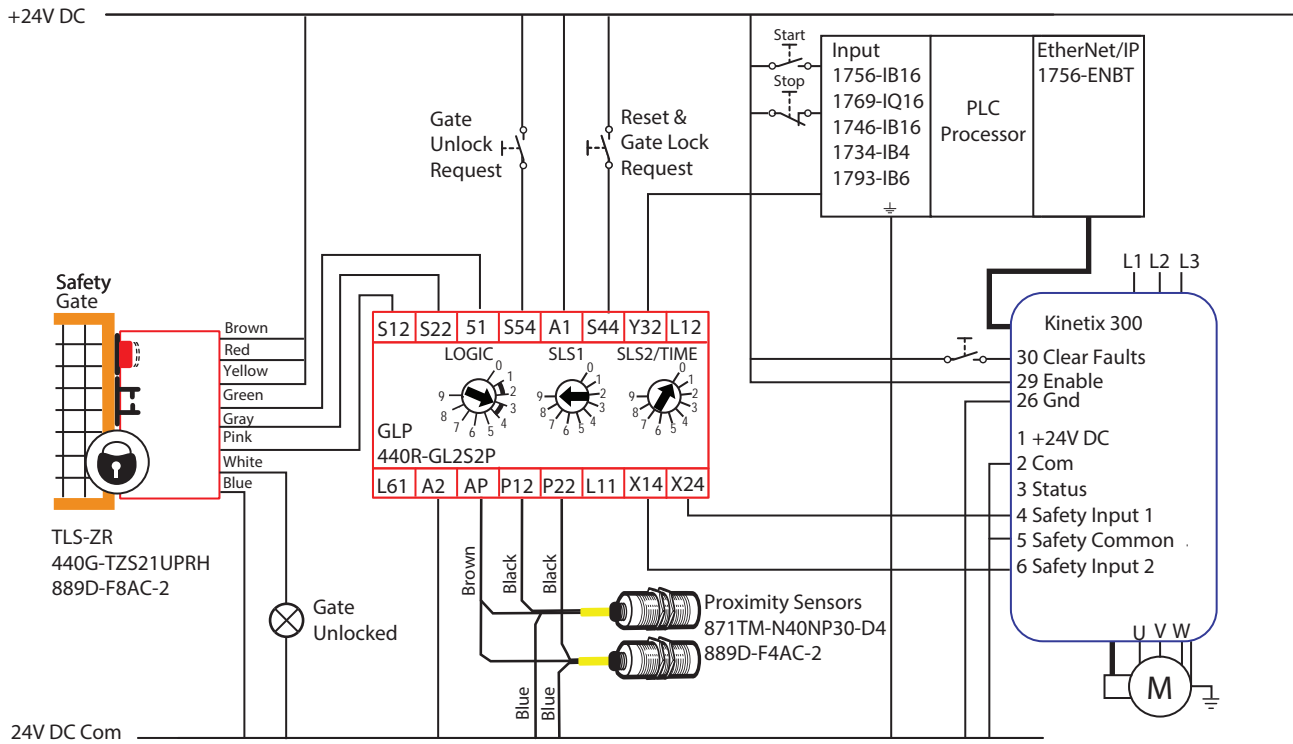

## Safely-limited Speed with Logic In, Guard Locking and Proximity Sensors

### Circuit Components

- Bulletin 440G-LZ guard locking switch
- Bulletin 871TM proximity sensors
- Bulletin 800F E-stop
- SI, GLP, and EM safety relays
- PowerFlex 525 drive

### Circuit Status

The E-stop is released. The safety gate is closed and locked. The SI and GLP are ready for reset. The GLP safety relay has a logic setting of 4: (Safely-limited speed with Logic IN), a safely-limited speed (SLS1) setting of 3 (3 Hz, 1.75 seconds) and a maximum speed setting (SLS2/Time) of 5 (200 Hz). The proximity sensors are rated for 400 Hz. The K1...K4 contactors are off. The GLP safety outputs (X14 and X24), the single wire safety output (L11), and the auxiliary output (Y32) are OFF. The motor is off.

**TIP** Start the GLP logic configuration from “0” to configure X14 and X24 for use as safety outputs.

### Operating Principle

This example is a cascaded safety system using the GSR single wire safety connections from L11 to L12. The E-stop turns off K1 and K2 and also instructs the GLP safety relay to issue a safely-limited speed command to the Preset Freq input of the PowerFlex 525 drive. The safely-limited speed command can also be initiated by pressing the Gate Unlock Request, which leaves K1 and K2 energized.

**STARTING:** Press the Reset button on the SI safety relay to energize K1 and K2 and to enable the GLP safety relay through the single wire safety connection (L11 to L12). Then, press the Reset and Gate Lock Request button to lock the gate and turn the GLP safety outputs ON. Press the Start button to turn the motor ON.

**STOPPING:** Initiate safely-limited speed by taking either of the following actions:

- Press the E-stop, which turns off K1 and K2 and initiates the Gate Unlock Request function in the GLP safety relay
- Press the Gate Unlock Request, which leaves K1 and K2 energized and initiates a safely-limited speed command to the PowerFlex 525 drive.

When the proximity sensors detect speed below the safely-limited speed of 3 Hz for 1.75 seconds, the gate unlocks.

### Fault Detection

Upon power-up, the safety devices perform internal checks. The GLP safety outputs are pulse tested to check for faults. The GLP safety relay uses redundant proximity sensors that must be mounted on independent fixtures. The PowerFlex 525 drive requires two safety signals to enable the drive. The SI safety relay monitors K1 and K2. The GLP safety relay monitors K3 and K4.

**OVERSPEED:** If the proximity sensors detect a speed above the SLS2 (200 Hz) when the gate is locked or above 3 Hz when the gate is unlocked, the auxiliary output (Y32), the safety outputs (X14 & X24), and the single wire safety output (L11) turn off.

### Ratings

The safety functions meet the safety performance requirements of SIL CL 2 per IEC 62061:2005 and have a Category 3 structure that can be used in systems that require Performance Levels up to PLd per ISO 13849-1:2006. This circuit executes a Stop Category 0 for fault conditions.

**Figure 41 - Safely-limited Speed with Logic In, Guard Locking and Proximity Sensors**

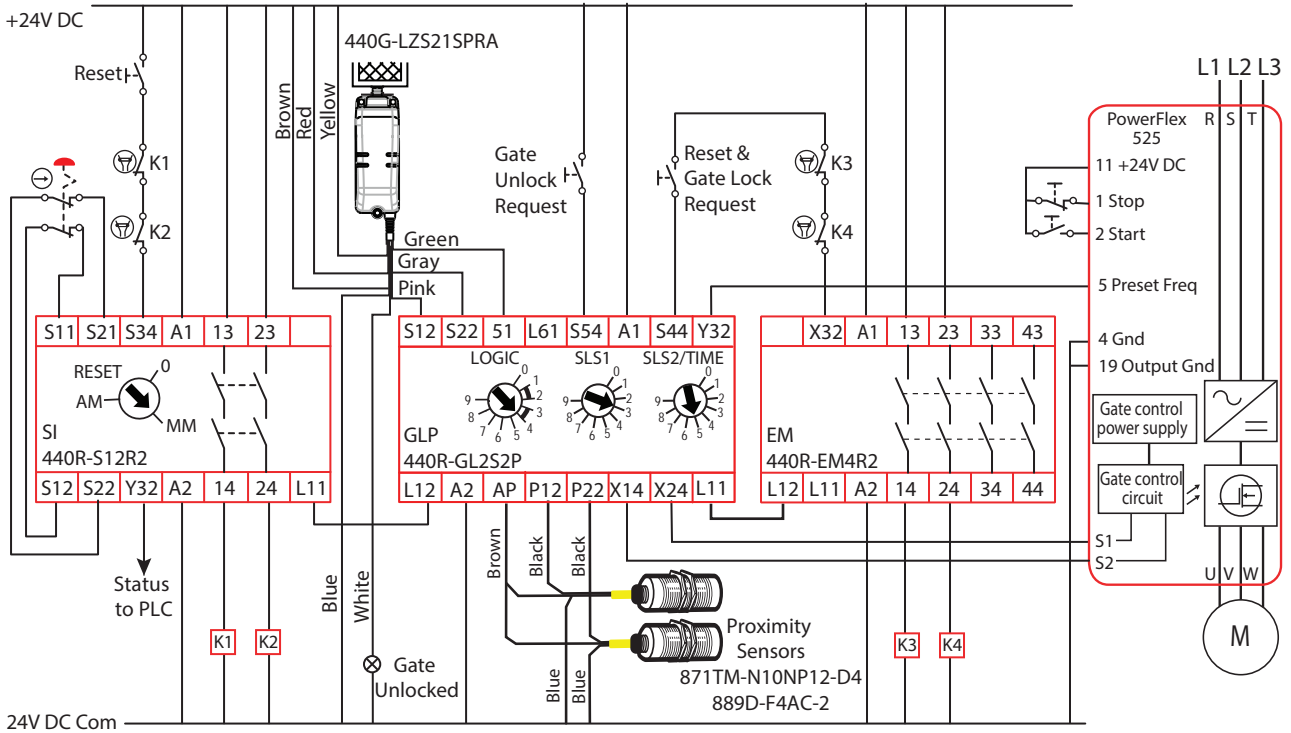

## Stop Motion with Guard Locking and E-stop

### Circuit Components

- Bulletin 440G-LZ guard locking switch
- Bulletin 872C proximity sensors
- GLP and EM safety relays

### Circuit Status

The gate is closed and locked. The GLP safety relay outputs X14 and X24 are OFF. The PowerFlex 525 drive is disabled, and the motor is OFF. The GLP safety relay is ready for reset. The GLP safety relay has a Logic setting of 5 (Stop Motion with 1...10 seconds Unlock Delay), a Frequency Measuring Time (SLS1) setting of 1 (1 Hz, 5.05 seconds) and a SLS2/Time setting of 3 (40% of the Delay).

**TIP** Start the GLP configuration from “0” when using Logic setting 5

The TLS-ZR guard locking interlock can replace the 440G-LZ guard locking switch, using the same wiring connections.

The S12, S22, S44, and S54 inputs do not have any functionality and do not need any connections.

### Operating Principle

When the proximity sensors detect speed below 1 Hz (the SLS1 setting), the GLP safety relay starts the timer set by SLS1. When the 5.05 seconds expire, the GLP safety relay turns on Y32, X14, X24, and L11 and starts the unlock timer. The unlock timer is 4 seconds (40% of 10 seconds), which the Logic switch setting and the SLS2/Time setting determine. After 4 seconds, the GLP safety relay unlocks the 440G-LZ guard locking switch.

When the gate is locked, contactors K1...K2 are energized and K3...K7 are de-energized. When the gate is unlocked, K1...K2 are de-energized and K3...K7 are energized.

### Fault Detection

Upon power-up, the 440G-LZ guard locking switch and GLP safety relay perform internal checks. The 440G switch checks its OSSD outputs for faults. The GLP safety relay uses redundant proximity sensors that must be mounted on independent fixtures.

### Ratings

The safety function meets the safety performance requirements of SIL CL 2 per IEC 62061:2005 and has a Category 3 structure that can be used in systems that require Performance Levels up to PLd per ISO 13849-1:2006.



**Figure 42 - Stop Motion with Guard Locking and E-stop**

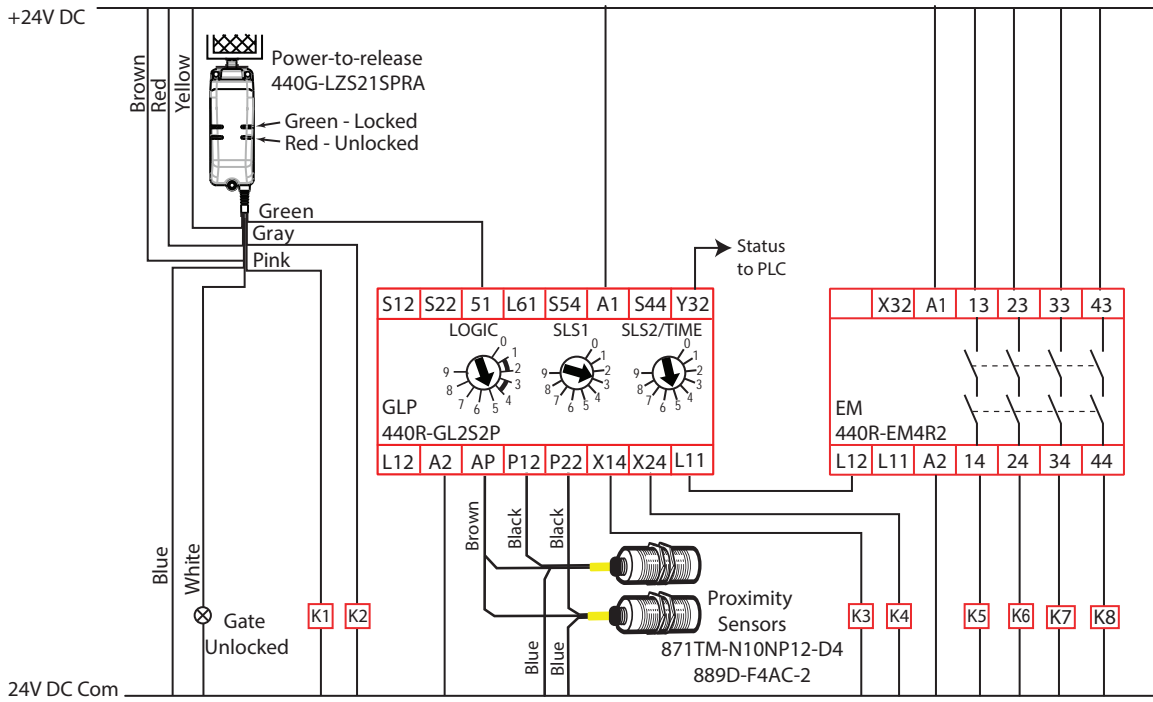

## Stop Motion to PLC

### Circuit Components

- Bulletin 872C proximity sensors
- GLP safety relay
- CR30 configurable safety relay
- Bulletin 1734 POINT Guard I/O

### Circuit Status

This example shows how to use the GLP safety relay for stop motion detection only. The GLP has a logic setting of 5: (delayed unlocking with automatic reset), a safely-limited speed (SLS1) setting of 0 (0.5 Hz) and an SLS2/Time of 0 (unlock delay of 10%). The SLS2/Time setting is not relevant as the 51/L61 locking signals are not used in this application.

**TIP** Start the GLP logic configuration from “0” when using Logic setting 5.

### Operating Principle

When the proximity sensors detect speed above 0.5 Hz, the X14, X24 outputs turn OFF. When the proximity sensors detect speed below 0.5 Hz, the X14 and X24 outputs turn ON.

The X14 and X24 outputs can be connected to other safety-rated devices like POINT Guard IO and the CR30 safety relay.

### Fault Detection

Upon power-up, the GLP safety relay, POINT Guard I/O, and CR30 safety relay perform internal checks. The GLP safety relay uses dual-channel OSSD outputs that check for fault conditions. The POINT Guard I/O blocks are safety-rated and a GuardLogix safety PLC must control them.

### Ratings

The safety function meets the safety performance requirements of SIL CL 2 per IEC 62061:2005 and has a Category 3 structure that can be used in systems that require Performance Levels up to PLd per ISO 13849-1:2006.

**Figure 43 - Stop Motion to PLC**

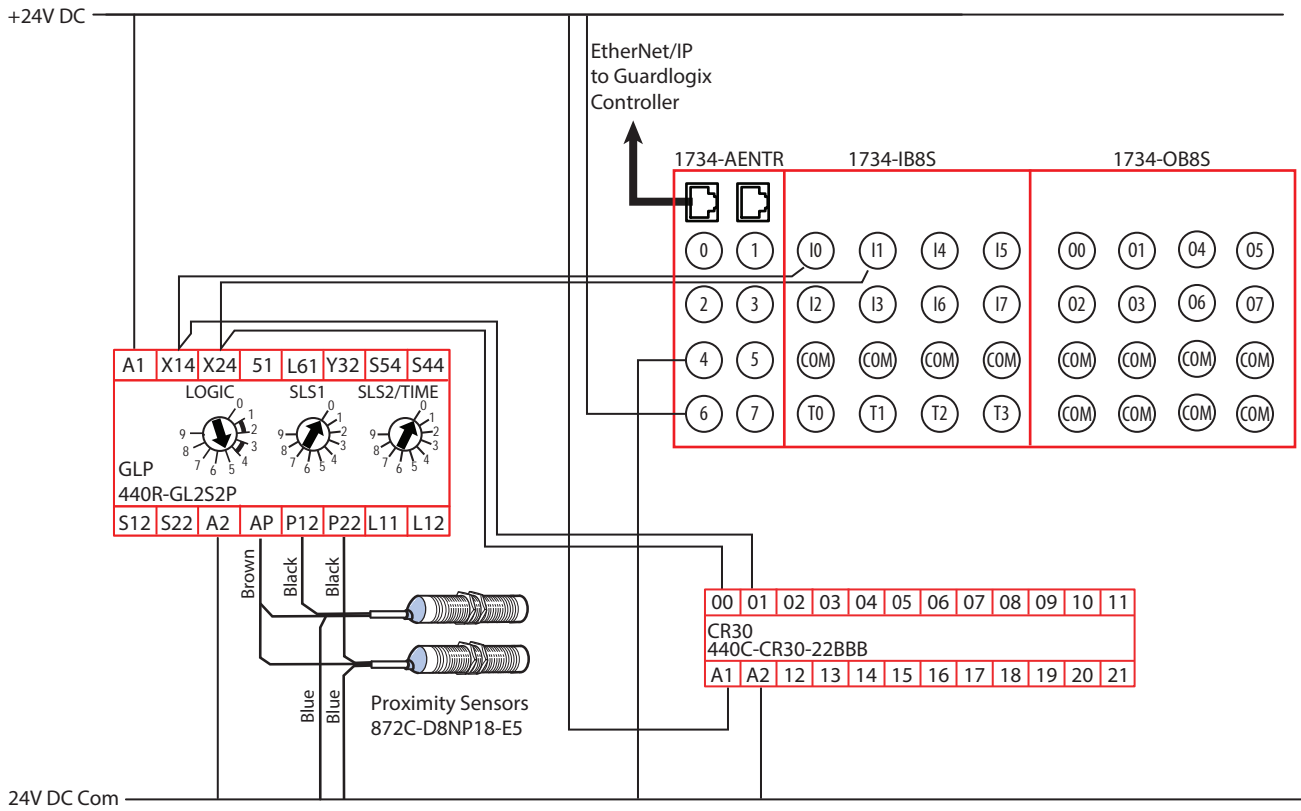

## Speed Status Only

### Circuit Components

- Bulletin 872C proximity sensors
- GLP safety relay

### Circuit Status

The GLP safety relay has a Logic setting of 8: (speed status only), a safely-limited speed (SLS1) setting of 0 (0.5 Hz, 10.1 seconds) and a maximum (SLS2/Time) speed setting of 5 (200 Hz).

**TIP** Start the GLP configuration from “9” to configure for speed status only.

### Operating Principle

The GLP safety relay is used to provide outputs that are a function of the speed the proximity sensors detect and the thresholds set by the SLS1 and SLS2/Time switches.

When the proximity sensors detect speed below the SLS1 setting, all GLP outputs are OFF.

When the proximity sensors detect speed above the SLS1 setting and below the SLS2/Time setting, the 51 and L61 outputs turn ON.

When the proximity sensors detect speed above the SLS2 setting, the L11, X14, X24, and Y32 outputs turn ON. The 51 and L61 outputs remain ON.

When the proximity sensors detect speed below the SLS2 setting, the L11, X14, X24, and Y32 outputs turn OFF immediately. The 51 and L61 outputs remain ON.

When the proximity sensors detect speed below the SLS1 (0.5 Hz) setting, the GLP safety relay starts the SLS1 timer. After 10.1 seconds, the GLP safety relay turns off 51 and L61.

### Fault Detection

Upon power-up, the GLP safety relay performs internal checks. If the checks are completed safely, the GLP safety relay reads the speed of the redundant proximity sensors, and turns ON the appropriate outputs. The 51/L61, X14/X24, and L11 outputs are safety-rated outputs that check for short-circuit conditions.

### Ratings

The safety function meets the safety performance requirements of SIL CL 2 per IEC 62061:2005 and has a Category 3 structure that can be used in systems that require Performance Levels up to PLd per ISO 13849-1:2006.

**Figure 44 - Speed Status Only**

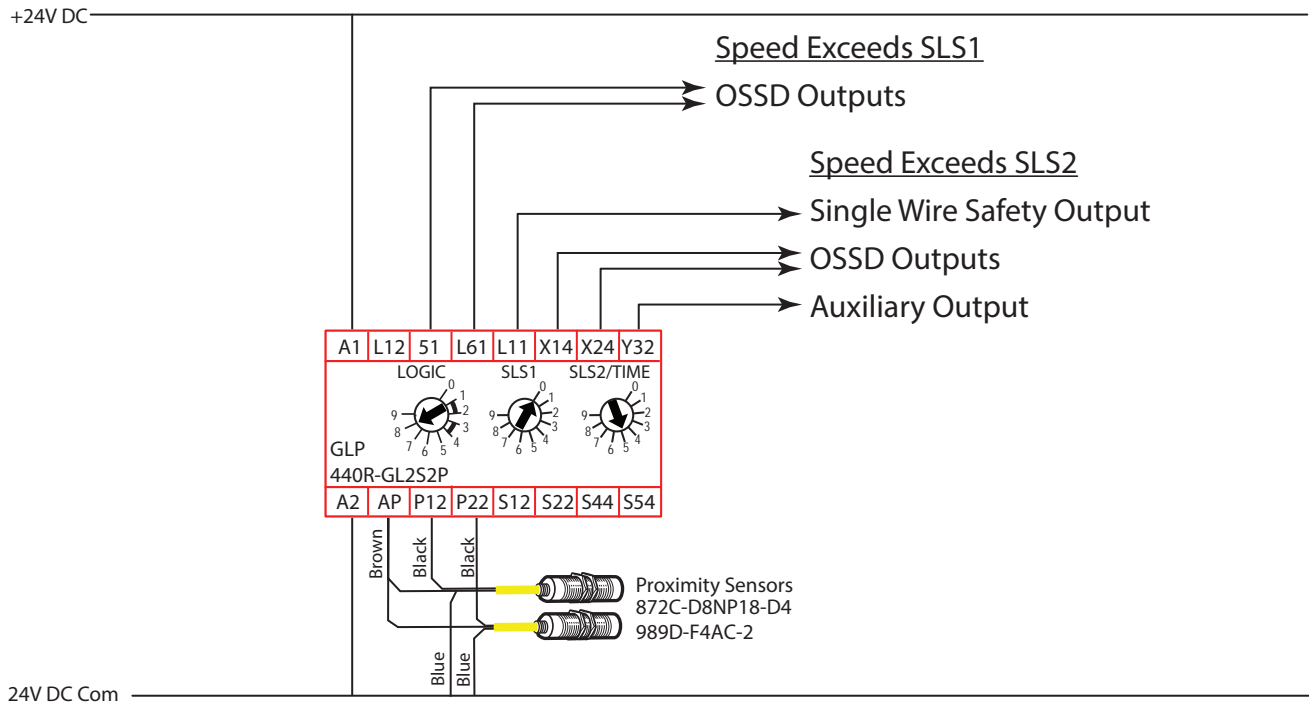

## Guard Locking with Time Delay

### Circuit Components

- TLS3-GD2 guard locking switch
- Guard Locking with Time-delay (GLT) safety relay
- PowerFlex 525

### Circuit Status

The gate is closed and locked. The TLS3-GD2 is a Power to Release guard locking interlock. The motor is off. The GLT safety relay is ready for reset. The GLT safety relay has a Logic setting of 1: (Stop Cat 0 with Logic In OFF), a Range setting of 4 (10 seconds) and a Time setting of 7 (70%). The delay is 7 seconds (70% of 10 seconds).

**TIP** Start the GLT safety relay configuration from “0” to generate test pulses as S11, S21, 14, and 24.

### Operating Principle

**STARTING:** Press the Door Lock and Reset Request. After verifying that the gate is closed and locked, the GLT safety relay turns on output 14 and 24. The PowerFlex 525 drive is enabled. Press the Start button to start the motor.

**STOPPING:** Normal production stops and starts are performed using the Start/Stop buttons. When access through the safety gate is needed, press the Door Unlock Request button. Outputs 14 and 24 turn OFF immediately, and the motor coasts to a stop. After 7 seconds, the GLT safety relay applies power to terminals 51 and L61 to unlock the gate.

### Fault Detection

Upon power-up, the TLS3-GD2 interlock switch, GLT safety relay, and PowerFlex 525 drive perform internal checks. The GLT safety relay generates test pulses on terminals S11 and S21 to check for short circuits on the guard locking switch. The TLS3-GD2 solenoid is powered through redundant wiring. The 14 and 24 outputs of the GLT safety relay are pulse tested to check for short-circuit conditions. The PowerFlex 525 drive has dual safety inputs and is safety rated.

### Ratings

The safety function meets the performance requirements of SIL 2 per IEC 62061: 2005, has a Category 3 structure and can be used in systems that require Performance Levels up to PLd per ISO 13849-1: 2006. The safety function performs Stop Category 0.

**Figure 45 - Guard Locking with Time Delay**

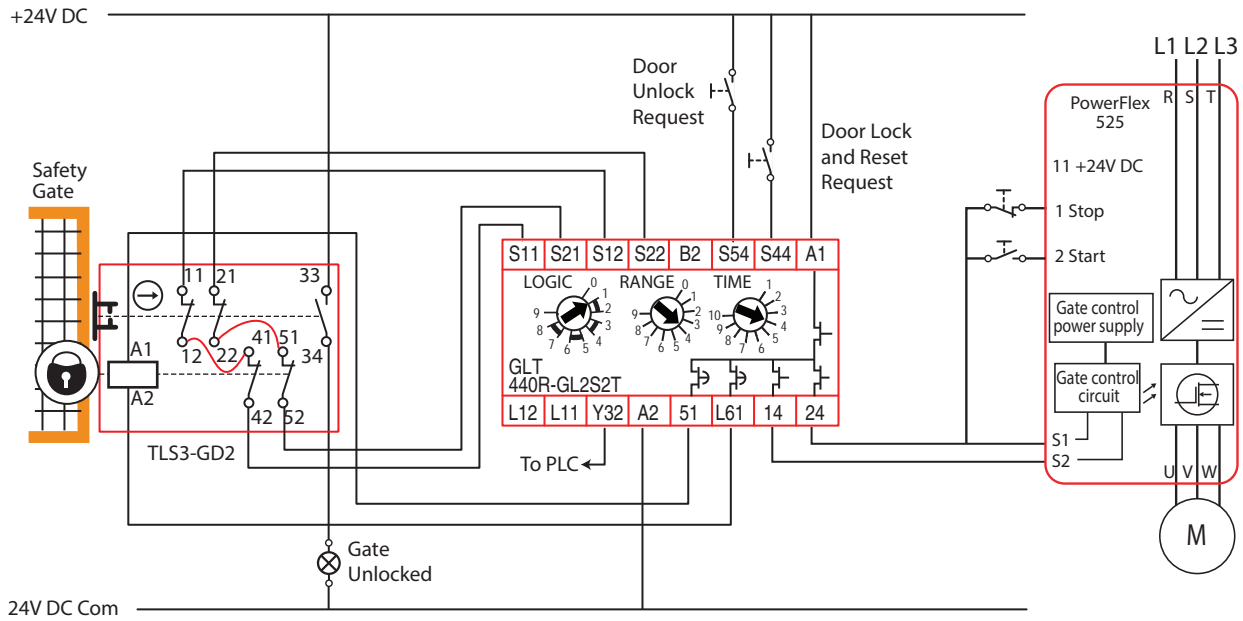

## Guard Locking with Time Delay

### Circuit Components

- Bulletin 440G-LZ guard locking switch
- GLT safety relay
- PowerFlex 525

### Circuit Status

The gate is closed and locked. The 440G-LZ is a Power to Release guard locking switch. The motor is off. The GLT safety relay is ready for reset. The GLT safety relay has a Logic setting of 1: (Stop Cat 0 with Logic In OFF), a Range setting of 4 (10 seconds) and a Time setting of 7 (70%). The delay is 7 seconds (70% of 10 seconds).

**TIP** Start the GLT safety relay configuration from “0” to generate test pulses as S11, S21, 14, and 24. S11 and S21 are not used with the 440G-LZ.

The TLS-ZR guard locking switch can replace the 440G-LZ guard locking switch with the same wiring connections.

### Operating Principle

**STARTING:** Press the Door Lock and Reset Request. After verifying that the gate is closed and locked, the GLT turns on its 14 and 24 outputs. The PowerFlex 525 drive is enabled. Press the Start button to start the motor.

**STOPPING:** Normal production stops and starts are performed using the Start/Stop buttons. When access through the safety gate is needed, press the Door Unlock Request button. The 14 and 24 outputs turn OFF immediately, and the motor coasts to a stop. After 7 seconds, the GLT safety relay applies power to terminals 51 and L61 to unlock the gate.

### Fault Detection

Upon power-up, the 440G-LZ guard locking switch, GLT safety relay, and PowerFlex 525 drive perform internal checks. The 440G-LZ switch has OSSD outputs to check for short circuits. Outputs 14 and 24 of the GLT safety relay are pulse tested to check for short-circuit conditions. The PowerFlex 525 drive has redundant safety inputs and is safety rated.

### Ratings

The safety function meets the performance requirements of SIL 2 per IEC 62061: 2005, has a Category 3 structure and can be used in systems that require Performance Levels up to PLd per ISO 13849-1: 2006. The safety function performs Stop Category 0.



**Figure 46 - Guard Locking with Time Delay**

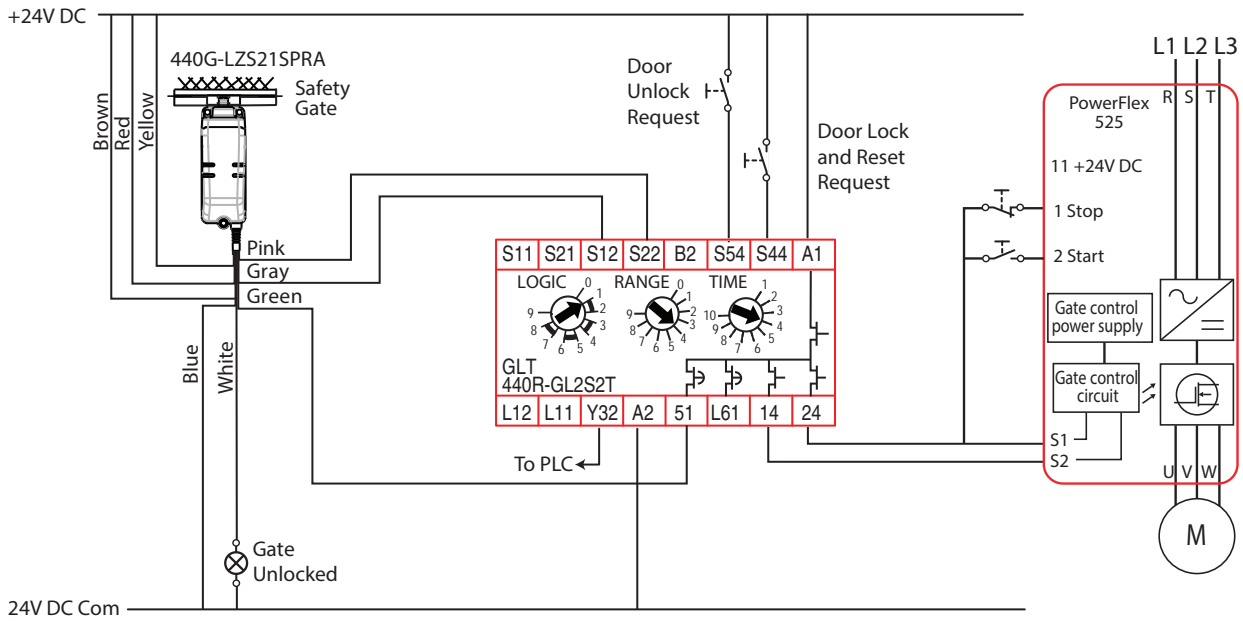

## Guard Locking with Time Delay

### Circuit Components

- Bulletin 440G-LZ guard locking switches
- GLT safety relay
- PowerFlex 525

### Circuit Status

The safety gates are closed and locked. The 440G-LZ is Power to Release guard locking switch. The motor is off. The GLT safety relay is ready for reset. The GLT safety relay has a Logic setting of 1: (Stop Cat 0 with Logic In OFF), a Range setting of 4 (10 seconds) and a Time setting of 7 (70%). The delay is 7 seconds (70% of 10 seconds).

**TIP** Start the GLT safety relay configuration from “0” to generate test pulses as S11, S21, 14, and 24. S11 and S21 are not used with the 440G-LZ.

The solenoid locking signals require low current (5 mA) and can be wired in parallel. The TLS-ZR guard locking switches can replace the 440G-LZ switches using the same wiring.

### Operating Principle

**STARTING:** Press the Door Lock and Reset Request. After verifying that the gates are closed and locked, the GLT safety relay turns on outputs 14 and 24. The PowerFlex 525 drive is enabled. Press the Start button to start the motor.

**STOPPING:** Normal production stops and starts are performed using the Start-Stop buttons. When access through the safety gates is needed, press the Door Unlock Request button. Outputs 14 and 24 turn OFF immediately, and the motor coasts to a stop. After 7 seconds, the GLT safety relay applies power to terminals 51 and L61 to unlock the gates.

### Fault Detection

Upon power-up, the 440G-LZ switches, GLT safety relay, and PowerFlex 525 drive perform internal checks. The 440G-LZ switches have OSSD outputs to check for short circuits. The 14 and 24 outputs of the GLT are pulse tested to check for short-circuit conditions. The PowerFlex 525 drive has redundant safety inputs and is safety rated.

### Ratings

The safety function meets the performance requirements of SIL 2 per IEC 62061: 2005, has a Category 3 structure and can be used in systems that require Performance Levels up to PLd per ISO 13849-1: 2006. The safety function performs Stop Category 0.

**Figure 47 - Guard Locking with Time Delay**

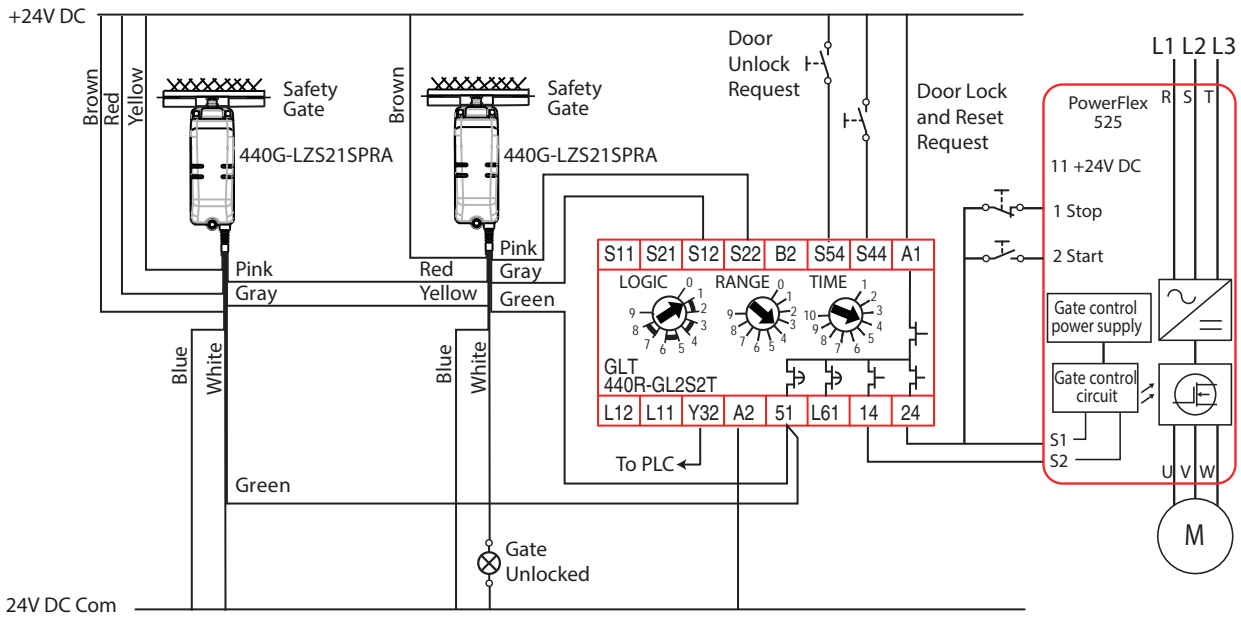

## Guard Locking with Delayed Unlock

### Circuit Components

- MAB
- GLT safety relay
- PowerFlex 525

### Circuit Status

The gate is closed and locked. The MAB is a Power to Release guard locking interlock. The motor is off. The GLT is ready for reset. The GLT has a Logic setting of 1: (Stop Cat 0 with Logic In OFF), a Range setting of 4 (10 seconds) and a Time setting of 7 (70%). The delay is 7 seconds (70% of 10 seconds).

**TIP** Start the GLT safety relay configuration from “0” to generate test pulses as S11, S21, 14, and 24. S11 and S21 are not used with the MAB.

### Operating Principle

**STARTING:** Press the Door Lock and Reset Request. After verifying that the gate is closed and locked, the GLT safety relay turns on its 14 and 24 outputs. The PowerFlex 525 drive is enabled. Press the Start button to start the motor.

**STOPPING:** Normal production stops and starts are performed using the Start/Stop buttons. When access through the safety gate is needed, press the Door Unlock Request button. The 14 and 24 outputs turn OFF immediately, and the motor coasts to a stop. After 7 seconds, the GLT safety relay applies power to terminals 51 and L61 to unlock the gate.

### Fault Detection

Upon power-up, the MAB, GLT safety relay, and PowerFlex 525 drive perform internal checks. The MAB has OSSD outputs to check for short circuits. The Fault Reset switch clears a fault within the MAB. Outputs 14 and 24 of the GLT safety relay are pulse tested to check for short-circuit conditions. The PowerFlex 525 drive has redundant safety inputs and is safety rated.

### Ratings

The safety function meets the performance requirements of SIL 2 per IEC 62061: 2005, has a Category 3 structure and can be used in systems that require Performance Levels up to PLd per ISO 13849-1: 2006. The safety function performs Stop Category 0.

**Figure 48 - Guard Locking with Delayed Unlock**

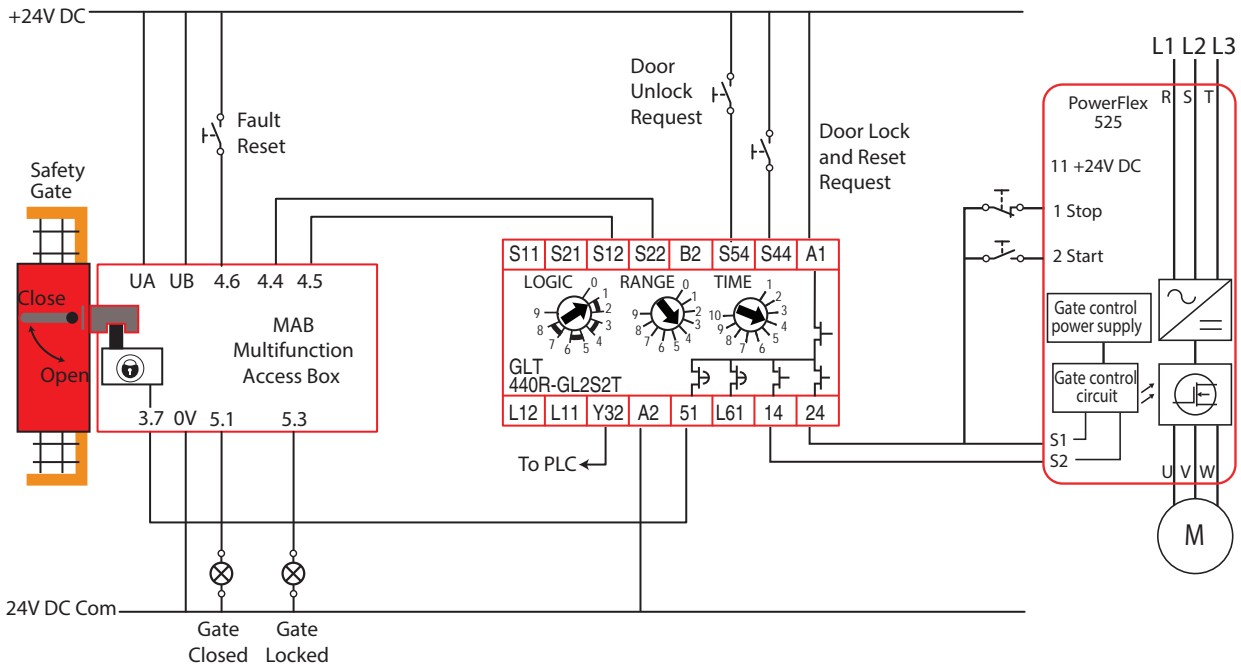

## Guard Locking with Time Delay

### Circuit Components

- MAB
- SI and GLT safety relays
- Bulletin 100S contactor

### Circuit Status

The gate is closed and locked. The MAB is a Power to Release guard locking interlock. The K1 and K2 contactors are off. The GLT safety relay is ready for reset. The GLT safety relay has a Logic setting of 2: (Stop Cat 0 with Logic In AND IN1), a Range setting of 3 (10 seconds) and a Time setting of 6 (60%). The delay is 6 seconds (60% of 10 seconds).

**TIP** Start the GLT safety relay configuration from “0” to generate test pulses as S11, S21, 14, and 24. The MAB does not use S11 and S21 because terminals 4.4 and 4.5 are OSSD outputs. The E-stop is released; the SI outputs, including L11, are closed.

The MAB is configured with three buttons:

- A latching dual-channel E-stop
- A momentary Unlock
- A momentary Lock and Reset button

The two momentary buttons are also status indicators that show if the gate is locked and/or closed.

### Operating Principle

**STARTING:** With the E-stop button released, press the Lock and Reset button on the MAB. The GLT safety relay turns OFF terminal 51. After verifying that the gate is closed and locked, the GLT safety relay turns on its 14 and 24 outputs. The K1 and K2 contactors turn on their loads.

**STOPPING:** When normal access through the safety gate is needed, press the Unlock button. Outputs 14 and 24 turn OFF immediately, and the load coasts to a stop. After 6 seconds, the GLT safety relay applies power to terminal 51 to unlock the gate.

When an emergency situation exists, press the E-stop button on the MAB. The SI immediately sends a stop signal to the GLT safety relay through the L11/L12 connection. The GLT safety relay immediately turns K1 and K2 OFF and the load coasts to a stop. After a 6 second delay, the MAB is unlocked.

### Fault Detection

Upon power-up, the MAB, SI safety relay, and GLT safety relay perform internal checks. The MAB has redundant OSSD outputs to check for short circuits. The Fault Reset switch clears a fault within the MAB. The SI performs pulse testing of the E-stop button. The SI safety relay generates a single wire safety output (L11) to the GLT safety relay (L12) to initiate a shutdown. Outputs 14 and 24 of the GLT safety relay are pulse tested to check for short-circuit conditions. The reset circuit (S44) of the GLT safety relay checks the status of the K1 and K2 contactors.

### Ratings

The safety function meets the performance requirements of SIL 3 per IEC 62061: 2005, has a Category 4 structure and can be used in systems that require Performance Levels up to PLe per ISO 13849-1: 2006. The safety function performs Stop Category 0.

**Figure 49 - Guard Locking with Time Delay**

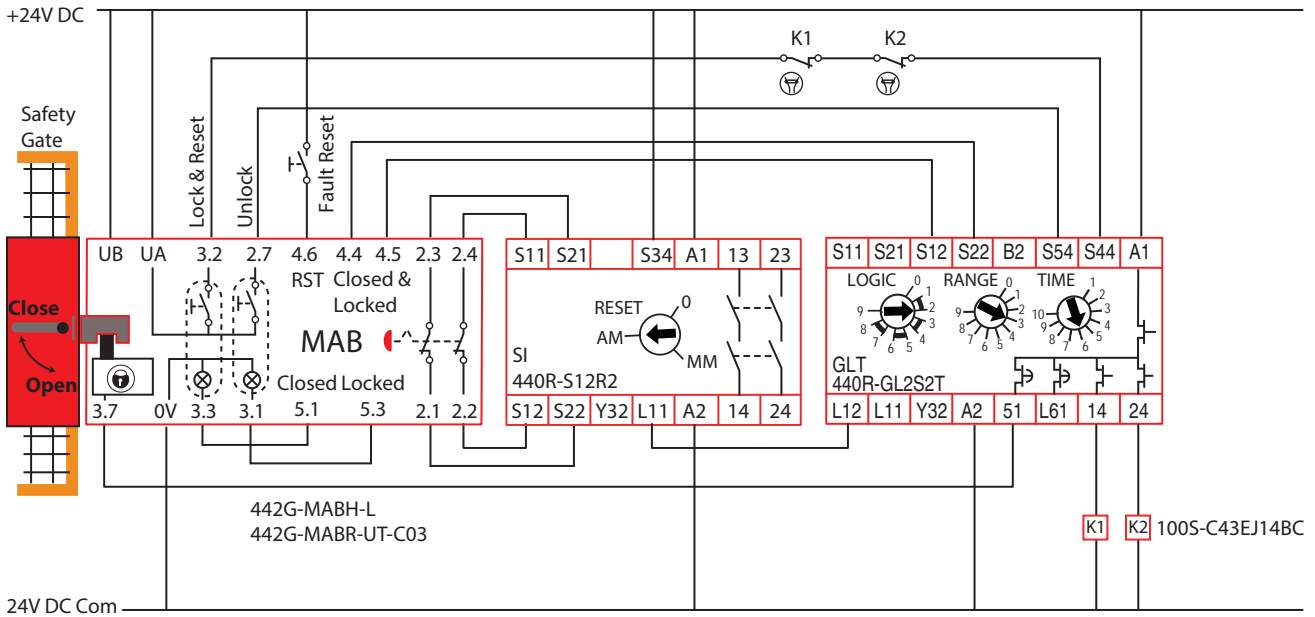

## Guard Locking with Time Delay and Stop Cat 1

### Circuit Components

- TLS-ZR guard locking switch
- GLT safety relay
- PowerFlex 525 drive

### Circuit Status

The gate is closed and locked. The TLS-ZR is a Power to Release guard locking switch. The motor is off. The GLT safety relay is ready for reset. The GLT safety relay has a Logic setting of 3: (Stop Cat 1 with Logic IN OR IN1), a Range setting of 4 (10 seconds) and a Time setting of 6 (60%). The delay is 6 seconds (60% of 10 seconds). With no connection to the Logic IN terminal L12, the GLT only uses the S12 and S22 inputs to initiate its safety function.

**TIP** Start the GLT safety relay configuration from “0” to generate test pulses as S11, S21, 14, and 24. S11 and S21 are not used with the TLS-ZR guard locking switch.

The TLS-ZR guard locking switch can be replaced with the 440G-LZ guard locking switch using the same wiring.

### Operating Principle

**STARTING:** Press the Door Lock and Reset Request button. After verifying that the gate is closed and locked, the GLT safety relay turns on its Y32, 14 and 24 outputs. The PowerFlex 525 drive is enabled. Press the Start button to start the motor.

**STOPPING:** Normal production stops and starts are performed using the Start/Stop buttons. When access through the safety gate is needed, press the Door Unlock Request button. The Y32 output turns OFF immediately, and the PowerFlex 525 drive performs its pre-programmed deceleration function. After 6 seconds, the GLT safety relay turns OFF terminals 14 and 24 to disable the PowerFlex 525 drive and applies power to terminal 51 to unlock the gate.

### Fault Detection

Upon power-up, the TLS-ZR guard locking switch, GLT safety relay, and PowerFlex 525 drive perform internal checks. The TLS-ZR guard locking switch has OSSD outputs to check for short circuits. The 14 and 24 outputs of the GLT safety relay are pulse tested to check for short-circuit conditions. The PowerFlex 525 drive has redundant safety inputs and is safety rated.

### Ratings

The safety function meets the performance requirements of SIL 2 per IEC 62061: 2005, has a Category 3 structure and can be used in systems that require Performance Levels up to PLd per ISO 13849-1: 2006. The safety function performs Stop Category 1.



**Figure 50 - Guard Locking with Time Delay and Stop Cat 1**

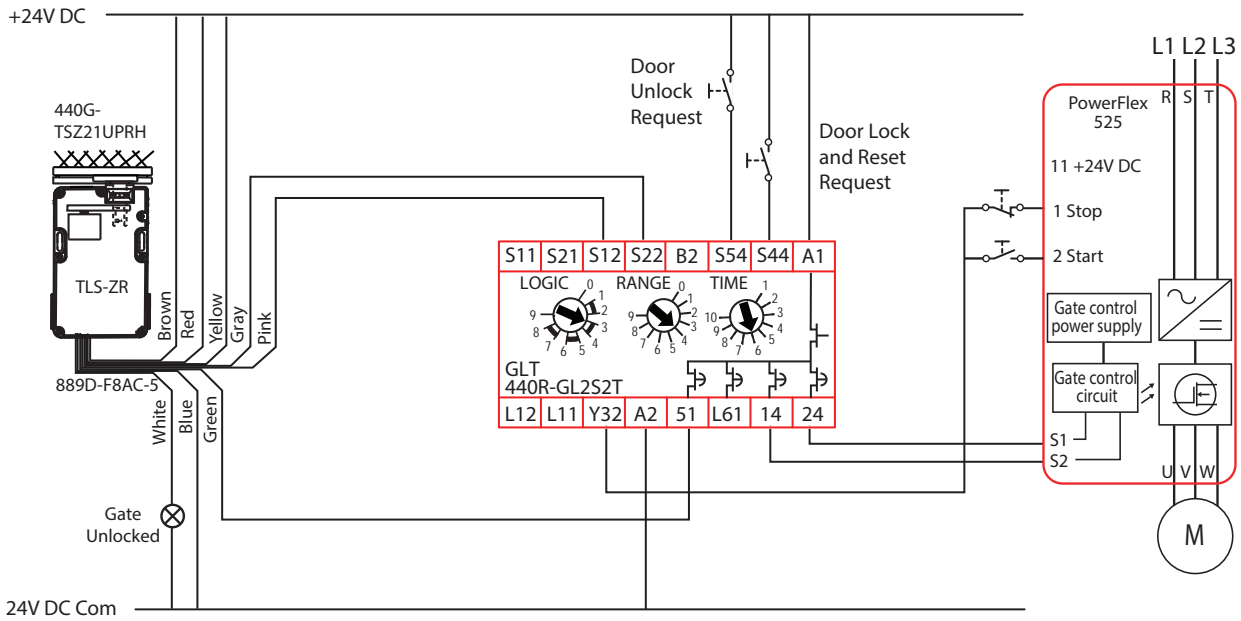

## Guard Locking with Time Delay and Stop Cat 1

### Circuit Components

- TLS-ZR guard locking switch
- SI and GLT safety relays
- PowerFlex 525 drive

### Circuit Status

The E-stop is released. Output L11 of the SI safety relay is active. The gate is closed and locked. The TLS-ZR is a Power to Release guard locking switch. The motor is off. The GLT safety relay is ready for reset. The GLT safety relay has a Logic setting of 4: (Stop Cat 1 with Logic IN AND IN1), a Range setting of 4 (10 seconds) and a Time setting of 6 (60%). The delay is 6 seconds (60% of 10 seconds).

**TIP** Start the GLT safety relay configuration from “0” to generate test pulses as S11, S21, 14, and 24. S11 and S21 are not used with the TLS-ZR guard locking switch. The GLT safety relay requires both S12, S22 and L12 to be ON to enable the PowerFlex 525 drive.

### Operating Principle

**STARTING:** With the E-stop released, press the Door Lock and Reset Request button. After verifying that the gate is closed and locked, the GLT safety relay turns on its Y32, 14 and 24 outputs. The PowerFlex 525 drive is enabled. Press the Start button to start the motor.

**STOPPING:** Normal production stops and starts are performed using the Start/Stop buttons. When access through the safety gate is needed, you have two options:

- Press the Door Unlock Request button
- Press the E-stop button.

The Y32 output turns OFF immediately, and the PowerFlex 525 drive performs its pre-programmed deceleration function. After 6 seconds, the GLT turns OFF 14 and 24 to disable the PowerFlex 525 drive and applies power to terminal 51 to unlock the gate.

### Fault Detection

Upon power-up, the TLS-ZR guard locking switch, SI safety relay, GLT safety relay, and PowerFlex 525 drive perform internal checks. The SI safety relay uses pulse testing to check for short-circuit conditions in the E-stop circuits. The L11 output of the SI safety relay is Single Wire Safety (SWS) capable of checking for short-circuit conditions. The TLS-ZR guard locking switch has OSSD outputs to check for short circuits. The 14 and 24 outputs of the GLT safety relay are pulse tested to check for short-circuit conditions. The PowerFlex525 has redundant safety inputs and is safety rated.

### Ratings

The safety function meets the performance requirements of SIL 2 per IEC 62061: 2005, has a Category 3 structure and can be used in systems that require Performance Levels up to PLd per ISO 13849-1: 2006. The safety function performs Stop Category 1.

**Figure 51 - Guard Locking with Time Delay and Stop Cat 1**

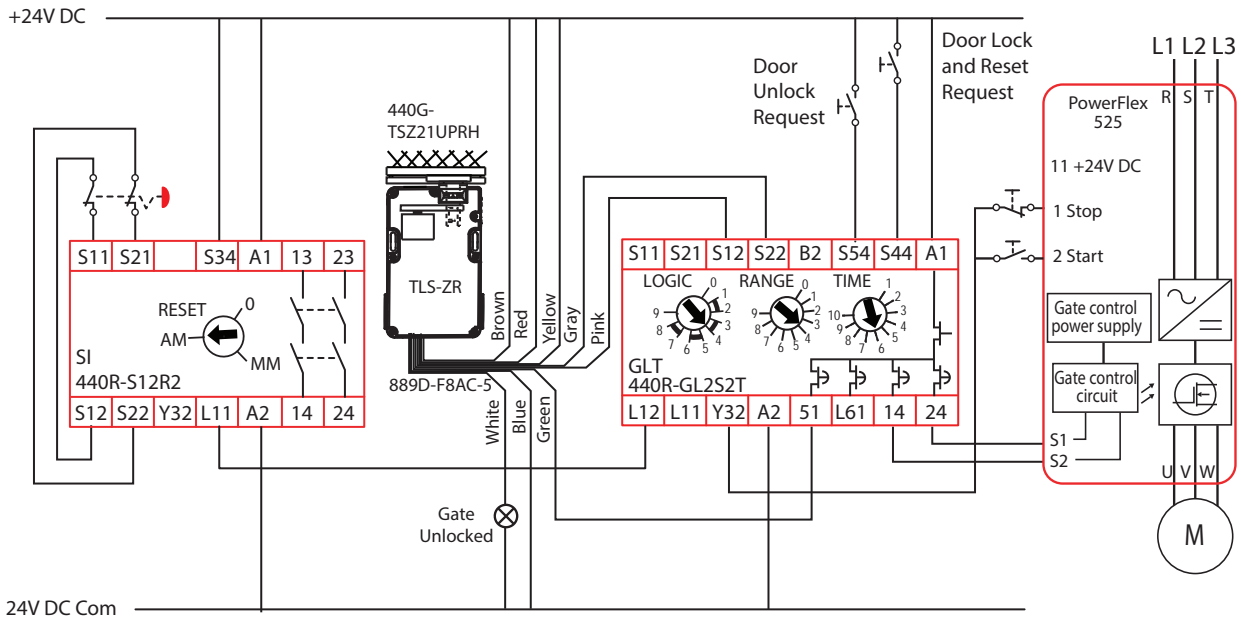

## E-stop with Monitored Reset and Stop Cat 0 and 1

### Circuit Components

- Bulletin 800F E-stop
- GLT safety relay
- PowerFlex 525 drive

### Circuit Status

The E-stop is released. Outputs 14, 24, 51, L61, L11, and Y32 of the GLT safety relay are OFF. The PowerFlex 525 drive is disabled and the motor is off. The GLT safety relay is ready for reset. The GLT safety relay has a Logic setting of 5: (E-stop Cat 1 with Logic IN OR IN1), a Range setting of 5 (30 seconds) and a Time setting of 5 (50%). The delay is 15 seconds (50% of 30 seconds).

**TIP** Start the GLT safety relay configuration from “0” to generate test pulses at S11, S21, 14, and 24.

### Operating Principle

**STARTING:** With the E-stop released, press the Reset button. The GLT safety relay turns on outputs Y32, L11, 51, L61, 14 and 24. Contactors K1 and K2 turn ON. The EM safety relay turns on via the L11/L12 connection and turns on contactors K3 and K4. The PowerFlex 525 drive is enabled. Press the Start button to start the motor.

**STOPPING:** Normal stops and starts of the motor are performed using the Start/Stop buttons. Emergency stops are initiated by pressing the E-stop button. The Y32, 14, 24 and L11 outputs turn OFF immediately. The EM safety relay turns off contactors K3 and K4, and PowerFlex 525 drive performs its pre-programmed deceleration function. After 15 seconds, the GLT safety relay turns OFF 51 and L61 to disable the PowerFlex 525 drive.

### Fault Detection

Upon power-up, the GLT safety relay, EM safety relay, and PowerFlex 525 drive perform internal checks. The GLT safety relay uses test pulses through the E-stop circuitry to test for short-circuit faults. The SWS signal from L11 of the GLT safety relay to L12 of the EM safety relay detects short-circuit conditions. The GLT safety relay reset circuit monitors the K1...K4 contactors; if one is stuck in the energized position, the GLT safety relay does not restart. The PowerFlex 525 drive has redundant safety inputs and is safety rated.

### Ratings

The PowerFlex 525 drive safety function meets the performance requirements of SIL 2 per IEC 62061: 2005, has a Category 3 structure and can be used in systems that require Performance Levels up to PLd per ISO 13849-1: 2006. The PowerFlex 525 drive safety function performs Stop Category 1.

If the contactors are used as redundant pairs, their safety function meets the performance requirements of SIL 3 per IEC 62061: 2005, has a Category 4 structure and can be used in systems that require Performance Levels up to PLe per ISO 13849-1: 2006. The K1...K4 contactors perform Stop Category 0.

**Figure 52 - E-stop with Monitored Reset and Stop Cat 0 and 1**

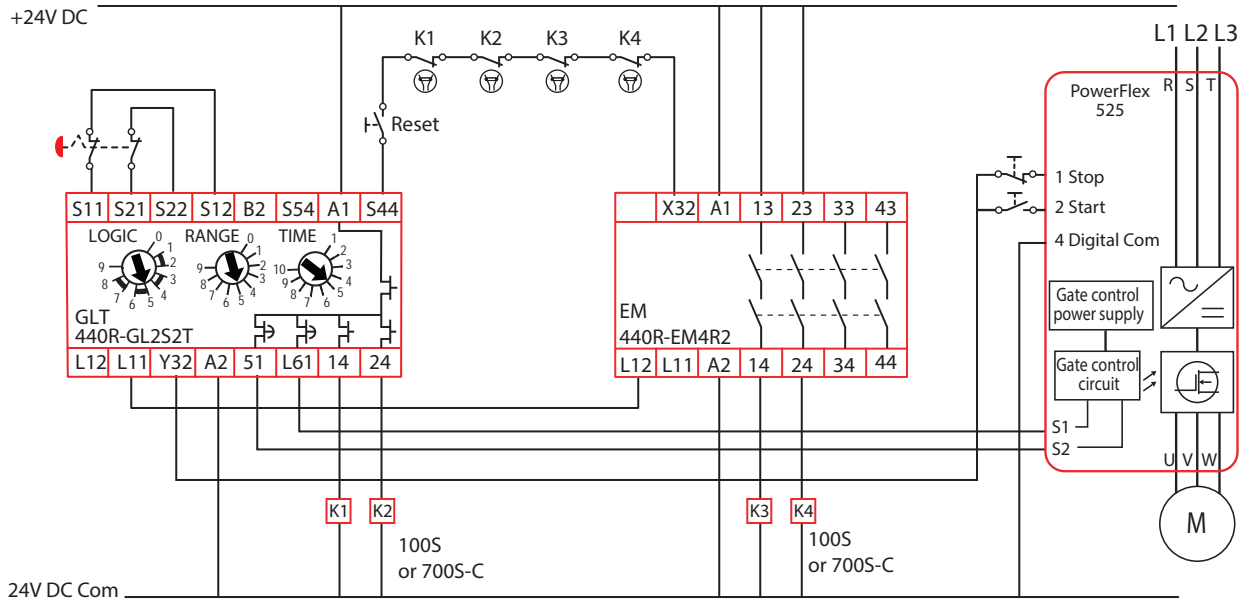

## Guard Locking with Time Delay

### Circuit Components

- MC2 magnetically coded non-contact interlock switch
- SI and GLT safety relays
- Bulletin 100S contactor
- PowerFlex 525 drive

### Circuit Status

The safety gate is closed and the SI safety relay outputs are ON. The E-stop is released and the GLT safety relay outputs are OFF. The GLT safety relay is ready for reset. The GLT safety relay has a Logic setting of 6: (Stop with Logic IN AND IN1 and Monitored Reset), a Range setting of 2 (3 seconds) and a Time setting of 6 (60%). The delay is 1.8 seconds (60% of 3 seconds).

**TIP** Start the GLT safety relay configuration from “0” to generate test pulses at S11, S21, 14, and 24.

### Operating Principle

The GLT safety relay requires both the E-stop to be released and the gate to be closed before the reset takes place. Once the gate is opened or E-stop is pressed, it must remain in that state during the timing cycle (or connect B2 to 24V DC to allow the GLT safety relay timer to retrigger).

**STARTING:** Press the Reset button. The GLT safety relay turns on Y32, 14, 24, 51, and L61. The K1 and K2 contactors turn on their loads. Press the Start button to turn on the motor.

**STOPPING:** Opening the gate or pressing the E-stop initiates a stop sequence. GLT outputs Y32, 14 and 24 turn off immediately. The K1 and K2 contactors turn off and the PowerFlex 525 drive executes its stop function. After 1.8 seconds, the 51 and L61 outputs turn off and disable the PowerFlex 525 drive.

### Fault Detection

Upon power-up, the SI safety relay, GLT safety relay, and PowerFlex 525 drive perform internal checks. The MC2 switch has redundant mechanical contacts that use the pulse testing of the SI safety relay to check for short-circuit conditions. The GLT safety relay uses pulse testing to check for short-circuit conditions in the E-stop circuits. The 14 and 24 outputs of the GLT safety relay are pulse tested to check for short-circuit conditions. The reset circuit (S44) of the GLT safety relay checks the status of the K1 and K2 contactors.

### Ratings

The PowerFlex 525 drive safety function meets the performance requirements of SIL 2 per IEC 62061: 2005, has a Category 3 structure, and can be used in systems that require Performance Levels up to PLd per ISO 13849-1: 2006. The PowerFlex 525 drive safety function performs Stop Category 1.

The contactors complete a safety function that meets the performance requirements of SIL 2 per IEC 62061: 2005, has a Category 3 structure and can be used in systems that require Performance Levels up to PLd per ISO 13849-1: 2006. The safety function performs Stop Category 0.

**Figure 53 - Guard Locking with Time Delay**

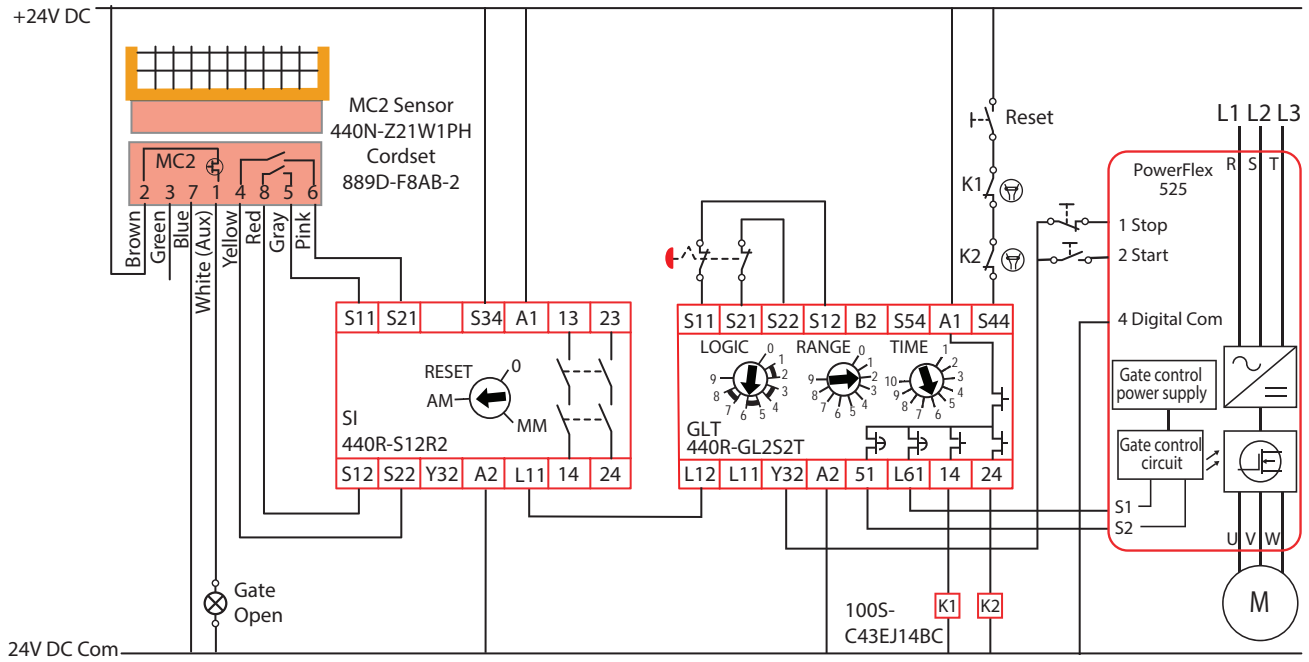

## E-stop with Auto Reset and Stop Cat 0 and 1

### Circuit Components

- TLS-ZR guard locking switch
- GLT safety relay
- PowerFlex 525 drive

### Circuit Status

The E-stop is released. Outputs 14, 24, 51, L61, L11, and Y32 of the GLT safety relay are ON. The PowerFlex 525 drive is enabled and the motor is off. The GLT safety relay has a Logic setting of 7: (E-stop Cat 1 with Logic IN OR IN1 with Auto Reset), a Range setting of 9 (30 min) and a Time setting of 10 (100%). The delay is 30 minutes (100% of 30 min).

**TIP** Start the GLT safety relay configuration from “0” to generate test pulses at S11, S21, 14, and 24.

### Operating Principle

The GLT safety relay has a connection to B2; the retriggerable input. If the E-stop is pressed, it can be released before the completion of the time delay without causing a recoverable fault in the GLT safety relay. When the E-stop is released, the immediate outputs turn back ON and the timer is reset.

**STARTING:** With the E-stop released, the GLT safety relay turns on its Y32, L11, 51, L61, 14, and 24 outputs. Contactors K1 and K2 turn ON. The EM relay turns on via the L11/L12 connection and turns on contactors K3 and K4. The PowerFlex 525 drive is enabled. Press the Start button to start the motor.

**STOPPING:** Normal stops and starts of the motor are performed using the Start/Stop buttons. Emergency stops are initiated by pressing the E-stop button. Outputs Y32, 14, 24 and L11 turns OFF immediately. The EM relay turns off contactors K3 and K4, and PowerFlex 525 drive performs its pre-programmed deceleration function. After 30 minutes, the GLT safety relay turns OFF 51 and L61 to disable the PowerFlex 525 drive.

### Fault Detection

Upon power-up, the GLT safety relay, EM relay, and PowerFlex 525 drive perform internal checks. The GLT safety relay uses test pulses through the E-stop circuitry to test for short-circuit faults. The SWS signal from L11 of the GLT safety relay to L12 of the EM relay detects short-circuit conditions. The reset circuit (S44) of the GLT safety relay checks the status of the K1...K4 contactors. If one is stuck in the energized position, the GLT safety relay does not restart. The PowerFlex 525 drive has redundant safety inputs and is safety rated.

### Ratings

The PowerFlex 525 drive safety function meets the performance requirements of SIL 2 per IEC 62061: 2005, has a Category 3 structure and can be used in systems that require Performance Levels up to PLd per ISO 13849-1: 2006. The PowerFlex 525 drive safety function performs Stop Category 1.

If the contactors are used as redundant pairs, their safety function meets the performance requirements of SIL 3 per IEC 62061: 2005, has a Category 4 structure and can be used in systems that require Performance Levels up to PLe per ISO 13849-1: 2006. The K1...K4 contactors perform Stop Category 0.



**Figure 54 - E-stop with Auto Reset and Stop Cat 0 and 1**

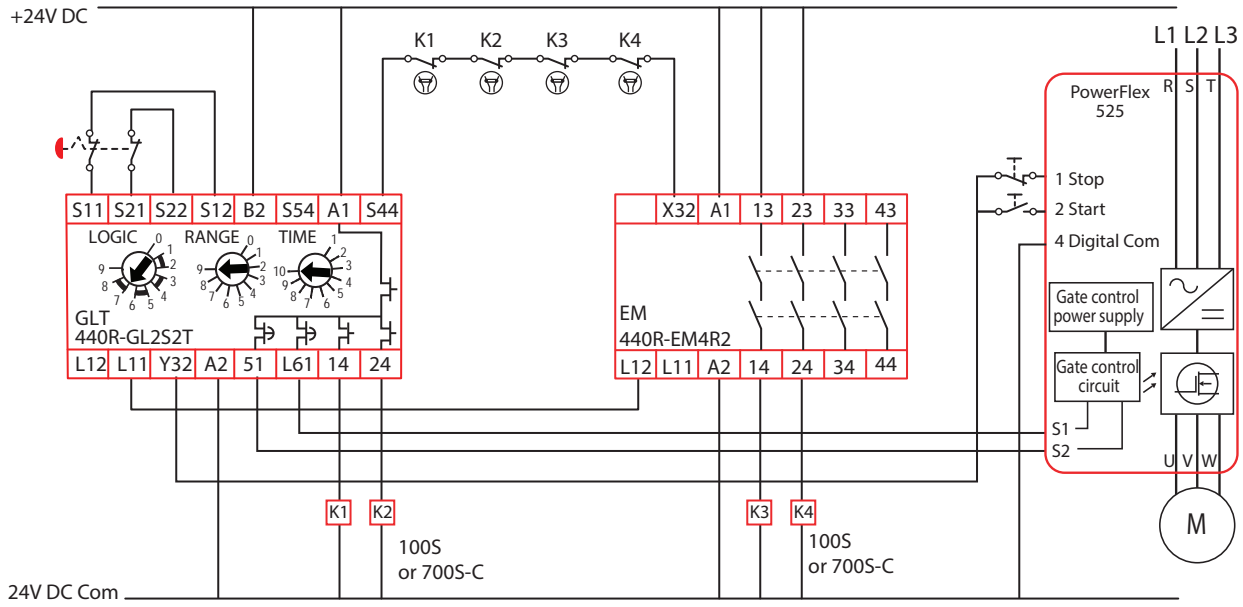

## Stop Cat 1 by Gate or E-stop

### Circuit Components

- Ferrogard GD2 non-contact interlock switch
- SI and GLT safety relays
- Bulletin 100S contactor
- PowerFlex 525 drive

### Circuit Status

The safety gate is closed. The SI safety relay, set to automatic reset, turns ON output L11. The E-stop is released and the GLT safety relay outputs are ON. The GLT safety relay has a Logic setting of 8: (Stop with Logic IN AND IN1 and Automatic Reset), a Range setting of 3 (3 seconds) and a Time setting of 7 (70%). The delay is 2.1 seconds (70% of 3 seconds).

**TIP** Start the GLT safety relay configuration from "0" to generate test pulses as S11, S21, 14, and 24.

### Operating Principle

The GLT safety relay requires both the E-stop to be released and the safety gate to be closed to energize its outputs.

The GLT safety relay has a connection to B2; the retriggerable input. If the E-stop is pressed, it can be released before the completion of the time delay without causing a recoverable fault in the GLT safety relay. When the E-stop is released, the immediate outputs turn back ON and the timer is reset.

**STARTING:** With the E-stop released, the GLT safety relay turns on outputs Y32, L11, 51, L61, 14 and 24. Contactors K1 and K2 turn ON. The PowerFlex 525 drive is enabled. Press the Start button to start the motor.

**STOPPING:** Normal stops and starts of the motor are performed with the Start/Stop buttons. Opening the gate or pressing the E-stop initiates a stop sequence. GLT safety relay outputs Y32, 14, and 24 turn off immediately. The K1 and K2 contactors turn off and the PowerFlex 525 drive executes its stop function. After 3.1 seconds, the 51 and L61 outputs turn off and disable the PowerFlex 525 drive.

### Fault Detection

Upon power-up, the SI safety relay, GLT safety relay, and PowerFlex 525 drive perform internal checks. The Ferrogard switch has redundant mechanical contacts that use the pulse testing of the SI safety relay to check for short-circuit conditions. The GLT safety relay uses pulse testing to check for short-circuit conditions in the E-stop circuits. Outputs 14 and 24 of the GLT safety relay are pulse tested to check for short-circuit conditions. The reset circuit (S44) of the GLT safety relay checks the status of the K1 and K2 contactors.

### Ratings

The PowerFlex 525 drive safety function meets the performance requirements of SIL 2 per IEC 62061: 2005, has a Category 3 structure and can be used in systems that require Performance Levels up to PLd per ISO 13849-1: 2006. The PowerFlex 525 drive safety function performs Stop Category 1.

The contactors complete a safety function that meets the performance requirements of SIL 2 per IEC 62061: 2005, has a Category 3 structure and can be used in systems that require Performance Levels up to PLd per ISO 13849-1: 2006. The safety function performs Stop Category 0.

**Figure 55 - Stop Cat 1 by Gate or E-stop**

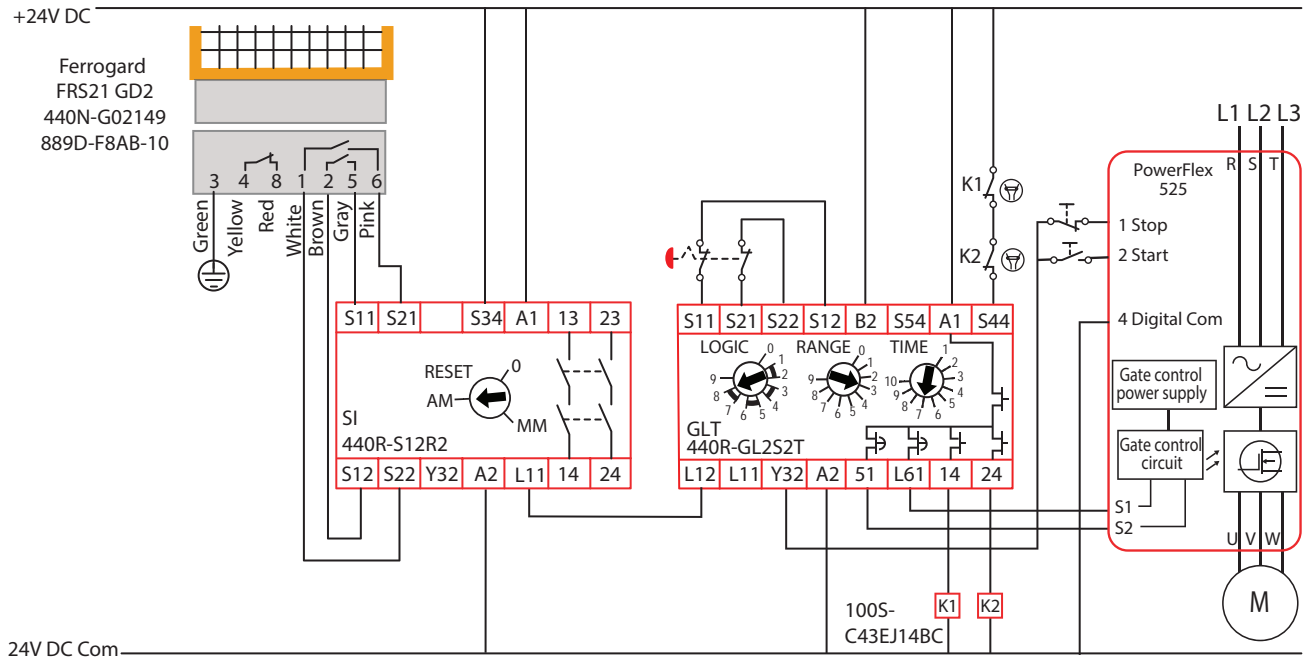

## EtherNet/IP to Logix Controllers

### Circuit Components

- Bulletin 440R-ENETR EtherNet/IP™ network interface
- DI, EM, DIS, EMD, GLT, and GLP safety relays

### Circuit Status

The schematic only shows the Ethernet, power, and SWS connections. The safeguarding connections are not shown.

### Operating Principle

The 440R-ENETR network interface must reside in the left-most position.

The GSR modules can be located in any order and must be firmware revision 2 or later.

The 440R-ENETR network interface has two Ethernet connections (one on top and one on bottom) that can be used in linear, star, or Device Level Ring topologies.

The 440R-ENETR network interface only reports status information for up to six relays with an Add-on Profile in the Logix Controller. The information can be used for ON/OFF status and troubleshooting.

**TIP** The CI and SI safety relays do not function with the 440R-ENETR network interface.

Figure 56 - EtherNet/IP to Logix Controllers

+24V DC

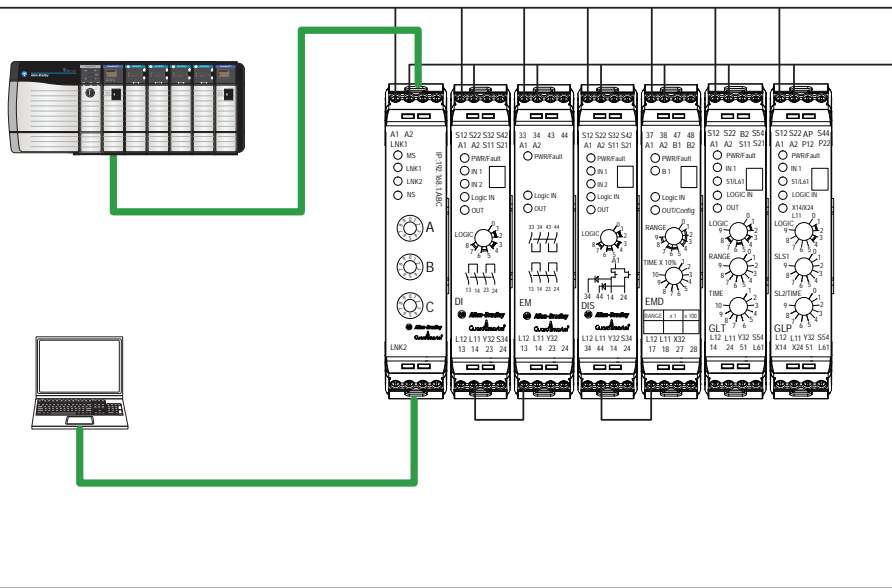

24V DC Com

## Using 100S-D Contactors with GSR Modules

### Circuit Components

- Bulletin 800F E-stop
- SI and EM safety relays
- Bulletin 100S-D safety contactors

### Circuit Status

The SI safety relay is set for monitored manual (MM) reset. The E-stop is released. The safety outputs of the SI and EM safety relays are de-energized. The control relays CR1 and CR2 are off. The contactors K1 and K2 are off. The motor is off.

### Operating Principle

Interposing relays are used in this circuit arrangement to minimize the impact of the inrush current of the 100S-D contactors. In the first 20 milliseconds of energization, the peak inrush current of the Bulletin 100S-D contactor is 25 A. For an additional 70 milliseconds, the Bulletin 100S-D contactor draws 10 A. Afterwards, the Bulletin 100S-D contactor has an approximate steady state holding current of 250 mA. See Knowledgebase document 32186 for further details on Bulletin 100S-D contactors.

When the Reset button is pressed, the SI and EM outputs turn on and energize interposing relays CR1 and CR2. The CR1 and CR2 relay contacts switch a quick, high current pulse ( $\sim 100 \mu\text{s}$ ). A signal through the 33/34 contacts of the EM safety relay informs the PLC that the safety system is ON, and the contactors are ready. The PLC then turns the Bulletin 100S-D contactors ON and OFF with low current (15 mA). To maximize life of the power supply and contactors, the PLC must stagger the energization of the K1 and K2 contactors by at least 200 milliseconds.

To achieve the safety rating when the E-stop is pressed, the A1 and B1 terminals must be disconnected through the safety circuits. When the E-stop is pressed, the SI and EM safety relays turn off immediately and disconnect the A1 and B1 circuits of both contactors.

The power supply (catalog number 1606-XLS480-3) is used to provide adequate inrush current (20 A rating with 30 A reserve power). The A1 connection of each contactor is connected to interposing relays to minimize replacement cost at End of Life due to contact wear out. The catalog number 700-HC2Z24 has a 15 A switching capability at 120V AC and a 10 A resistive load rating. By closing the relay contacts before the contactors are energized, the catalog number 700-HC2Z24 relay carries the 25 A inrush current rather than switching the inrush current. The connections to A1 and A2 must be a minimum of 2.5 mm<sup>2</sup> (14 AWG), and the total wire length must be less than 65.6 ft (20 m) for each contactor. The catalog number 700-HN103 relay base and 1492 terminal blocks can accommodate this wire size.

### Fault Detection

Upon power-up, the SI and EM safety relays perform internal checks. Using pulse testing that is generated at S11 and S21, the SI safety relay then looks for dual signals from the E-stop circuit on S12 and S22. The SI safety relay detects a cross fault on the E-stop circuit. With the E-stop signals made, the SI safety relay looks for the closing and opening of the reset signal on terminal S34. The Bulletin 100S-D contactors have mirrored contacts (one on each side of the housing). The mirrored contacts must be connected in series. If any of these mirrored contacts are not closed, the SI safety relay does not reset. CR1 and CR2 do not have to be monitored because the Bulletin 100S-D mirror contacts monitor them indirectly. The EM safety relay provides the source of the reset signal. If a fault occurs within the EM safety relay, X32 is not powered and the SI safety relay does not reset.

### Ratings

The E-stop button initiates a safety function that meets the safety performance requirements of SIL CL 3 per IEC 62061:2005 and has a Category 4 structure that can be used in systems requiring Performance Levels up to PLe per ISO 13849-1:2006. This circuit executes a Stop Category 0.

**Figure 57 - Using 1005-D Contactors with GSR Modules**

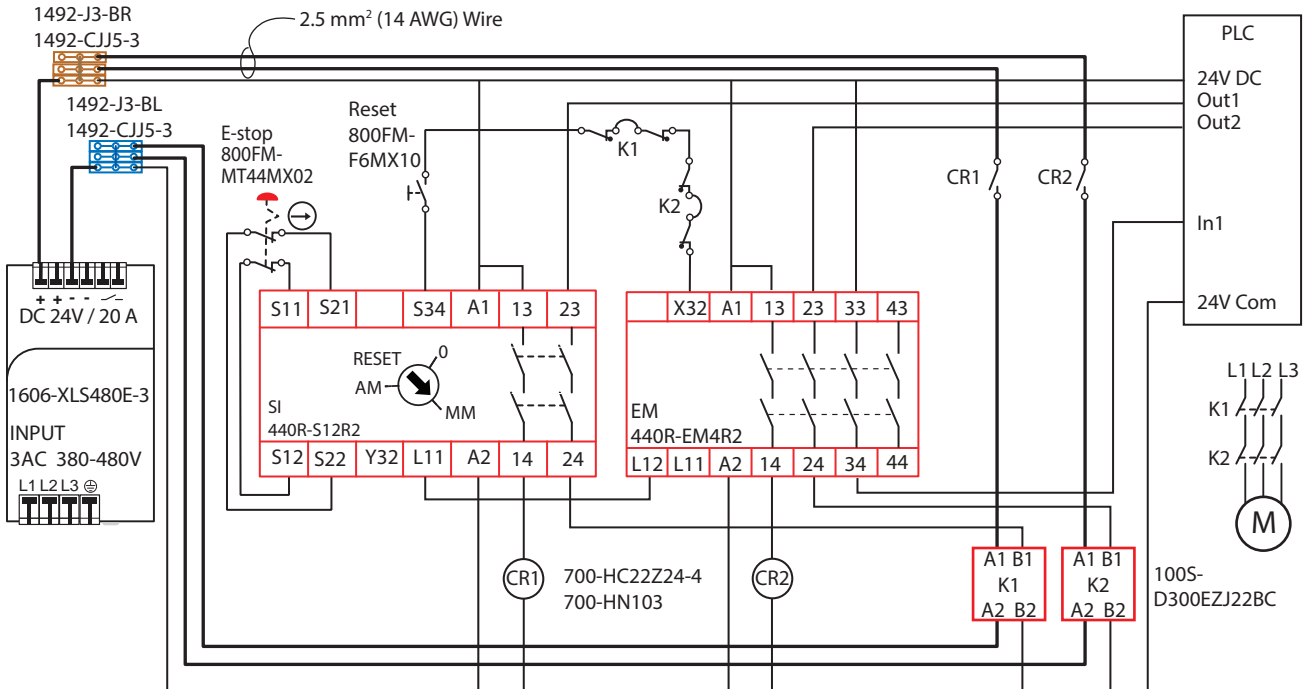

## Safely-limited Speed without Guard Locking

### Circuit Components

- SensaGuard integrated latch interlock
- Bulletin 871TM proximity sensors
- GLP safety relay
- PowerFlex 70 drive

### Circuit Status

The SensaGuard integrated latch interlock is closed, and the OSSD outputs are ON. The GLP safety relay is ready for reset. The GLP safety relay has a Logic setting of 3: (Safely-limited speed without Logic IN), a safely-limited speed (SLS1) setting of 0 (0.5 Hz), and a maximum speed setting (SLS2/Time) of 5 (200 Hz). The proximity sensors are rated for 400 Hz. The GLP safety relay outputs (X14 and X24), the single wire safety output (L11), and the auxiliary output (Y32) are OFF. The motor is off.

**TIP** Start the GLP logic configuration from "0" to configure X14 and X24 for use as safety outputs.

### Operating Principle

The GLP safety relay can be used without a guard locking type interlock. A safeguarding device with OSSD outputs or mechanical contacts can be used with GLP safety relay. In this example, a SensaGuard with integrated latch has OSSD outputs and does not have a locking feature. An interposing relay load (catalog number 700-TBR24, for example) or status indicator (catalog number 800L-18L24G, for example) can be connected between terminal 51 and ground to indicate when safely-limited speed is achieved. The risk assessment must verify that you cannot reach the hazard before the motor speed falls below the SLS1 setting when the SensaGuard switch is opened and the motor coasts to a stop.

**STARTING:** Press the Reset button to turn the GLP safety outputs ON and enable the PowerFlex 70 drive. Press the Start button to turn the motor ON.

**STOPPING:** Initiate a safety stop by taking either of the following actions:

- Press the Stop button
- Open the SensaGuard switch.

A press of the Stop button commands to PowerFlex 70 drive to execute the configured stop function (ramp the speed down, for example). When the SensaGuard switch opens the GLP safety relay output immediately turn OFF, and the PowerFlex 70 drive executes a coast-to-stop.

**SAFELY-LIMITED SPEED:** Press the SLS Request button. The Y32 output turns ON and commands the PowerFlex 70 drive to adjust the motor speed to the Speed Select 1 setting. When the speed drops below the SLS1 setting, terminal 51 turns ON the indicator to notify the user that the machine is running at a safe slow speed. You can open the SensaGuard switch, and the motor continues to run at the safe slow speed. The PWR/Fault status indicator on the GLP safety relay is green and flashes red six times. When the SensaGuard switch recloses, the GLP safety relay is ready to return to production speeds. You press the Reset button, and the Y32 output turns OFF, which returns the PowerFlex 70 drive to production operating speed.



### Fault Detection

Upon power-up, the safety devices perform internal checks. The GLP safety relay has dual-channel pulse tested outputs that check for faults. The PowerFlex 70 drive requires two safety signals to enable the drive.

**OVERSPEED:** If the proximity sensors detect a speed greater than the maximum speed (200 Hz), the auxiliary output (Y32), the safety outputs (X14 & X24), and the single wire safety output (L11) turn OFF. The PWR/Fault status indicator flashes at a 3X rate. When the speed drops below the maximum speed limit, press the Reset button to clear the fault and energize the safety outputs.

### Ratings

The safety function meets the safety performance requirements of SIL CL 2 per IEC 62061:2005 and has a Category 3 structure that can be used in systems requiring Performance Levels up to PLd per ISO 13849-1:2006. This circuit executes a Stop Category 1.

**Figure 58 - Safely-limited Speed without Guard Locking**

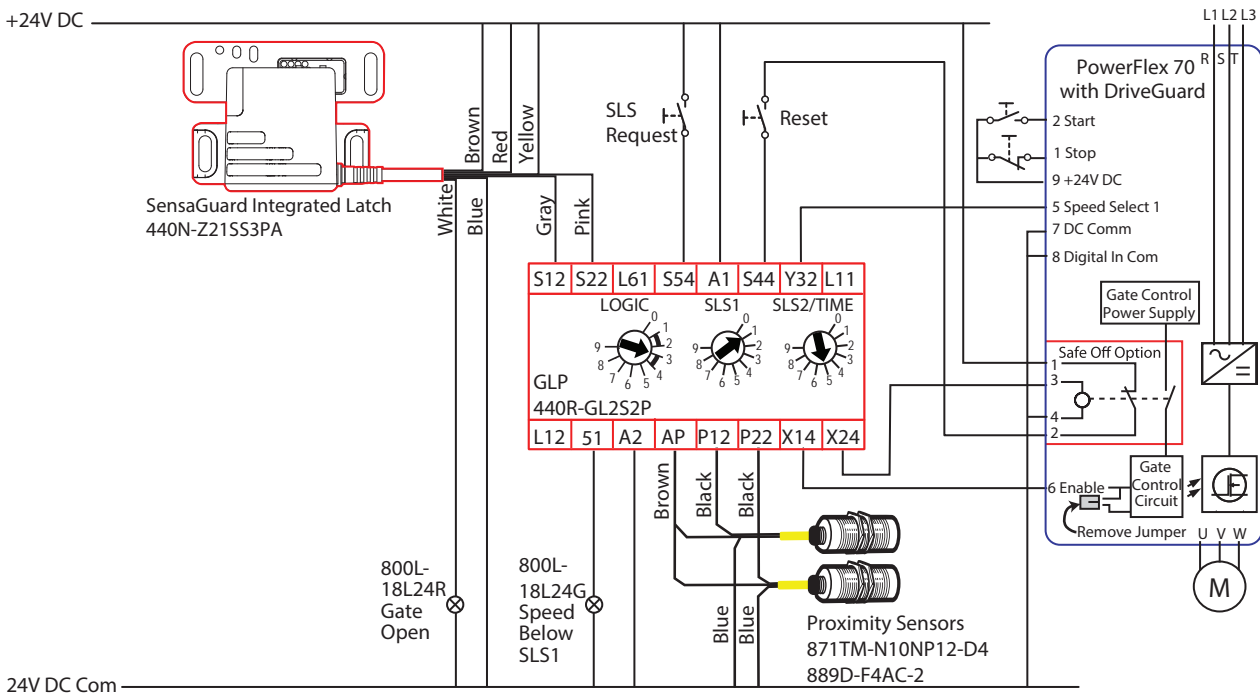

## Rockwell Automation Support

Use the following resources to access support information.

<b>Technical Support Center</b>	Knowledgebase Articles, How-to Videos, FAQs, Chat, User Forums, and Product Notification Updates.	<a href="http://www.rockwellautomation.com/knowledgebase">www.rockwellautomation.com/knowledgebase</a>
<b>Local Technical Support Phone Numbers</b>	Locate the phone number for your country.	<a href="http://www.rockwellautomation.com/global/support/get-support-now.page">www.rockwellautomation.com/global/support/get-support-now.page</a>
<b>Direct Dial Codes</b>	Find the Direct Dial Code for your product. Use the code to route your call directly to a technical support engineer.	<a href="http://www.rockwellautomation.com/global/support/direct-dial.page">www.rockwellautomation.com/global/support/direct-dial.page</a>
<b>Literature Library</b>	Installation Instructions, Manuals, Brochures, and Technical Data.	<a href="http://www.rockwellautomation.com/literature">www.rockwellautomation.com/literature</a>
<b>Product Compatibility and Download Center (PCDC)</b>	Get help determining how products interact, check features and capabilities, and find associated firmware.	<a href="http://www.rockwellautomation.com/global/support/pcdc.page">www.rockwellautomation.com/global/support/pcdc.page</a>

## Documentation Feedback

Your comments will help us serve your documentation needs better. If you have any suggestions on how to improve this document, complete the How Are We Doing? form at [http://literature.rockwellautomation.com/idc/groups/literature/documents/du/ra-du002\\_-en-e.pdf](http://literature.rockwellautomation.com/idc/groups/literature/documents/du/ra-du002_-en-e.pdf).

Rockwell Automation maintains current product environmental information on its website at <http://www.rockwellautomation.com/rockwellautomation/about-us/sustainability-ethics/product-environmental-compliance.page>.

Allen-Bradley, DriveGuard, Ferrogard, FLEX, GuardLogix, Guardmaster, GuardMotion, GuardShield, Kinetix, Lifeline, LISTEN. THINK. SOLVE., MatGuard, Minotaur, POINT Guard I/O, PowerFlex, Rockwell Automation, Rockwell Software, Safedge, SafeZone, SensaGuard, Trojan, and Zero-Force Touch Buttons are trademarks of Rockwell Automation, Inc.

DM2 and SERPAR are trademarks of Ross Controls.

DeviceNet and EtherNet/IP are trademarks of the ODVA.

Trademarks not belonging to Rockwell Automation are property of their respective companies.

Rockwell Otomasyon Ticaret A.Ş., Kar Plaza İş Merkezi E Blok Kat:6 34752 İçerenköy, İstanbul, Tel: +90 (216) 5698400

**[www.rockwellautomation.com](http://www.rockwellautomation.com)**

### Power, Control and Information Solutions Headquarters

Americas: Rockwell Automation, 1201 South Second Street, Milwaukee, WI 53204-2496 USA, Tel: (1) 414.382.2000, Fax: (1) 414.382.4444

Europe/Middle East/Africa: Rockwell Automation NV, Pegasus Park, De Kleetlaan 12a, 1831 Diegem, Belgium, Tel: (32) 2 663 0600, Fax: (32) 2 663 0640

Asia Pacific: Rockwell Automation, Level 14, Core F, Cyberport 3, 100 Cyberport Road, Hong Kong, Tel: (852) 2887 4788, Fax: (852) 2508 1846

Publication SAFETY-WD001K-EN-P - March 2018

Supersedes Publication SAFETY-WD001J-EN-P - August 2017

Copyright © 2018 Rockwell Automation, Inc. All rights reserved. Printed in the U.S.A.