

Measuring Light Array Sensors

Catalog Number 45MLA-ATx

IMPORTANT Save these instructions for future use.

Description

The Allen-Bradley® 45MLA measuring light array is a measurement sensor that uses an array of transmitted beam photoelectric sensor pairs to detect and measure objects. The array housing is compact, allowing for easy installation in a range of applications.

The 45MLA is packaged as transmitted beam pairs—the emitter and receiver arrays are both included. The system requires an Allen-Bradley 45MLA controller, which must be ordered separately.

The controller drives the photoelectric elements in the emitter and reads out the receiver beam information. Use of one of these external controllers allows the flexibility to:

- Output an analog signal (4...20 mA or 0...10V)
- Configure up to four separate sensing zones with independent outputs, or
- Communicate individual beam status via serial protocols.

Additionally, the 45MLA can also be customized for application-specific overhang and over-height detection.

Features

- Height measuring capability
- Slim profile array (16 x 20 mm [0.6 x 0.8 in.])
- Reinforced profile array (30 x 40 mm [1.2 x 1.6 in.]) and lengths from 1.8...3 m (5.9...9.8 ft)
- Beam spacing (pitch) of 10 mm (0.4 in.) or 25 mm (1.2 in.)
- Minimum detectable object is 18 mm (0.7 in.) or 33 mm (1.3 in.)
- Long operating range—4 m (13 ft)
- Fast reaction time and measurement speed
- Sensing array height of 150...1200 mm (5.9...47.2 in.)
 - IP54
 - Individual beam status available via controller (serial communication models only)
- Same housing as Allen-Bradley GuardShield™ Micro 400



ATTENTION: These devices are intended for object recognition only and can not be used for protection of humans (access protection).

Specifications

Attribute	45MLA-ATx
Environmental	
Certifications	cULus and CE Marked for all applicable directives
Operating Environment	IP54
Operating Temperature	0...+55 °C (+32...+131 °F)
Storage Temperature	-20...+70 °C (-4...+158 °F)
Vibration	10...55 Hz; amplitude 0.35 mm (0.01 in.); meets or exceeds IEC 60068-2-6
Shock	Acceleration 10 g, pulse duration 16 ms; 10...55 Hz; amplitude 0.35 mm (0.01 in.); meets or exceeds IEC 60068-2-29
Relative Humidity	15...95%
Optical	
Sensing Modes	Transmitted beam pair
Sensing Range	0...4 m (0...13 ft)
Field of View	3.2°
Light Source	940 nm
Beam Spacing (pitch)	10 mm (0.4 in.) or 25 mm (1.2 in.)
Minimum Detectable Object Height	18 mm (0.7 in.) or 33 mm (0.3 in.)
Status Indicators	Red: Status and Green: Alignment
Mechanical	
Housing Material	Aluminum
Lens Material	Polycarbonate
Cover Material	Polycarbonate
Connection Types	8-pin DC micro (M12) female QD on 500 mm (20 in.) cable pigtail (for connection to 45MLA controller only)
Accessories	
Supplied Accessories	Slim Profile: Adjustable mounting kit (445L-AF6143)
Required Accessories (Controller)	Controller Analog Model: 45MLA-CTRL-ALG Controller Basic Model: 45MLA-CTRL-BSC Controller I/O Model: 45MLA-CTRL Controller RS485: 45MLA-CTRL-485 Controller CAN: 45MLA-CTRL-CAN
Required Accessories (Light array to controller connecting cable)	2 m M12—RJ45: 445L-AC8RJ2 3 m M12—RJ45: 445L-AC8RJ3 5 m M12—RJ45: 445L-AC8RJ5 8 m M12—RJ45: 445L-AC8RJ8 Max. system length cannot exceed 10 m (32.8 ft)
Optional Accessories	Adjustable flat mounting bracket: 445L-AF6149 Flat mounting kit: 445L-AF6145 Cascadable array extension patchcord, M12 8-pin, 3M: 445L-AC8PC3 Reinforced profile: Mounting kit 445L-AF6140 Adjustable mounting kit: 445L-AF6141

Array Status Indicator	Description	Color	Meaning
Green (also status indicator D1 on controller)	Light array alignment	Off	Target present or arrays not aligned
		Green	Target not present, arrays that are aligned and within range
		Green (flashing)	Light intensity inadequate
Red (also status indicator D2 on controller)	Light array status	Off	Target not present (and arrays aligned)
		Red	Target present (or arrays not aligned)
		Red (flashing)	Height measurement error

Mounting Instructions

- Both the emitter and receiver profiles are lined with continuous grooves to attach to the mounting brackets. The grooves allow these brackets to be attached at any position along the length of the housing. **Note:** A flat mounting kit is also available for purchase separately.
- Align the emitter and receiver so that the two units are parallel to each other and the sides with the sensor elements (and the clear plastic lenses) are facing each other.
- The receiver (blue connector) can be sensitive to interference light. No other source of external light, including the emitters of any sensor, array, or reflective surface, can be directed towards the receiver housing. Although the 45MLA is tolerant of bright sunlight, it is better to mount the receiver so no sun light shines directly into the curved front area of the receiver lens.

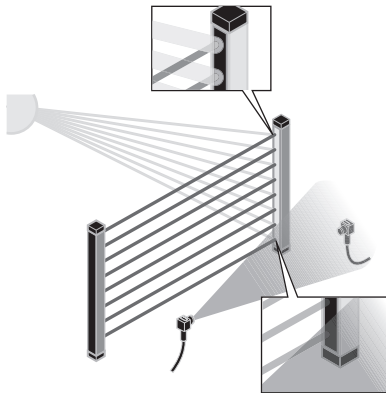

Electrical Installation

Both light arrays must be connected to the controller through the RJ45 connectors. For ease of connection, the pigtail connector for the emitter has a white marker, and the receiver has a blue marker. Be sure to connect the emitter to the plug connection on the controller with the white marker, and the receiver to the plug connection with a blue marker.

In addition, the connectors cables are offered with both blue and white rings that are attached to each end of each cable. Remove the blue markers from the emitter cable and the white ones from the receiver cable so that the cables are marked appropriately for future use.

The individual light arrays are powered through this connection to the controller. See the Installation Instructions corresponding to the specific controller that you are using for further details on wiring and connecting the controller.

Alignment

This alignment is a crucial step in the setup since sensor operation is dependent on correct alignment of the emitter and receiver. This process is simplified by using the green status indicator on the receiver unit to serve as an indication of proper alignment.

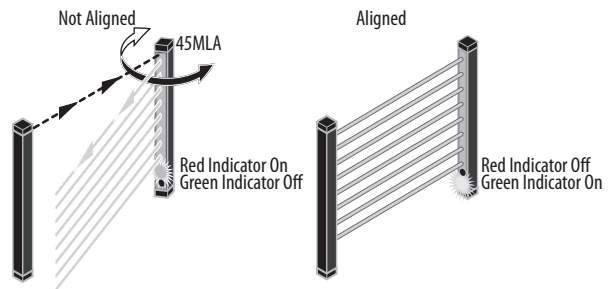

Horizontal Alignment

- Aim the receiver 90° away from the emitter (light source) and verify that the red status indicators on both the receiver and emitter are ON.
- Slowly rotate the receiver to face the emitter and note the point at which these red indicators turn OFF and the green alignment indicator turns ON.
- Continue to rotate the receiver away from the emitter until the green indicator turns OFF again, and the red indicator turns ON. Note the point at which it turns ON.
- For horizontal centering, rotate the array halfway between the two points at which the red indicator turns OFF.

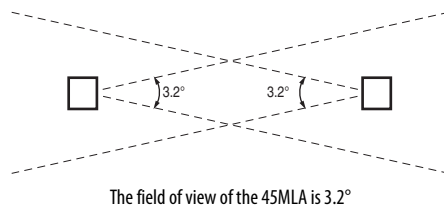

Vertical Alignment

- Beginning with the two arrays parallel to each other, slide the receiver down and note the point at which the red indicator turns ON on both arrays. This point indicates that the receiver is no longer in line with the emitter.
- Slide the receiver back upwards until the red indicator turns OFF and the green indicator on the receiver turns ON. This position indicates that the two arrays are aligned.

- Continue to slide the receiver upwards, noting the point at which the green indicator turns OFF, and the two red indicators turn ON, again indicating misalignment.
- For vertical centering, position the receiver halfway between the two points at which the red indicators turn OFF.

Wiring Diagram

The 45MLA is a “Three Box System”—every setup consists of an emitter array, a receiver array, and an external controller.

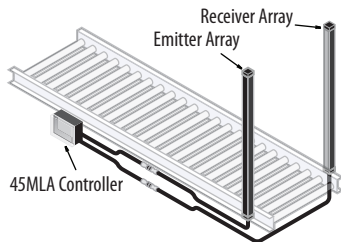

The 45MLA arrays feature an M12, 8-pin female QD, which connects to the connecting cable 445L-AC9RJx (x = 3, 5, or 8 meter length). The other end of the 445L connecting cable has an RJ45 connector, which plugs into the ports on the controller. The emitter plugs into the top port, marked with the white dot. The receiver plugs into the lower port, marked with the blue dot. The 445L connecting cable comes with both blue and white markers at each end. It is recommended to remove the markers that do not correspond to the array pigtail marker.

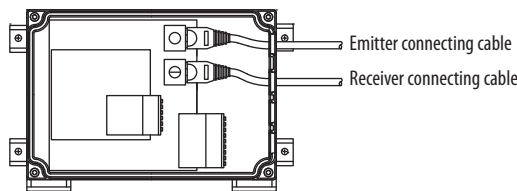

All electrical connections are made via the 45MLA-CTRL controller.

IMPORTANT Cascading light array systems can consist of two or three light array pairs. The last pair must be a standard array pair and the first (and middle) pairs must be cascable. A total system can be no more than 10 m (32.8 ft) in length from the controller to the end of the last array and cannot exceed 254 total beams.

IMPORTANT For use in NFPA 79 applications only.

Adjustable Bracket 445L-AF6143 (Slim Profile) (four pieces included) [mm (in.)]

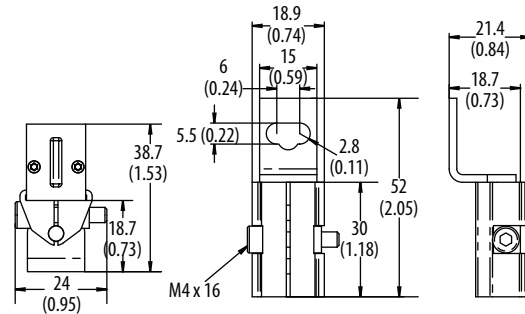

Optional 30 mm adjustable bracket for reinforced profile sold separately.

Flat Bracket 445L-AF6145 (sold separately) [mm (in.)] (Slim Profile)

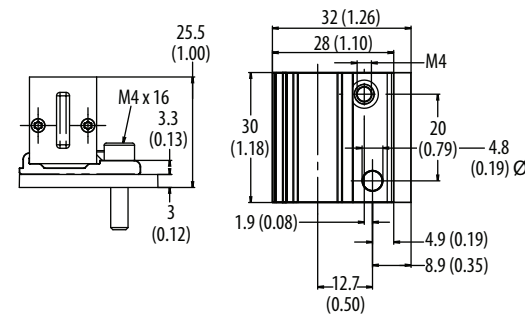

A 30 mm flat bracket for reinforced profile (2 x 2 mm [0.08 x 0.08 in.]) pieces are included.

Cascadable Array Extension Patchcord 445L-AC8PCx

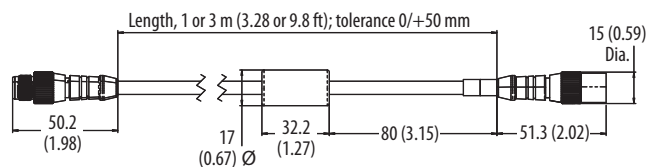

Dimensions [mm (in.)]

Slim Profile Array

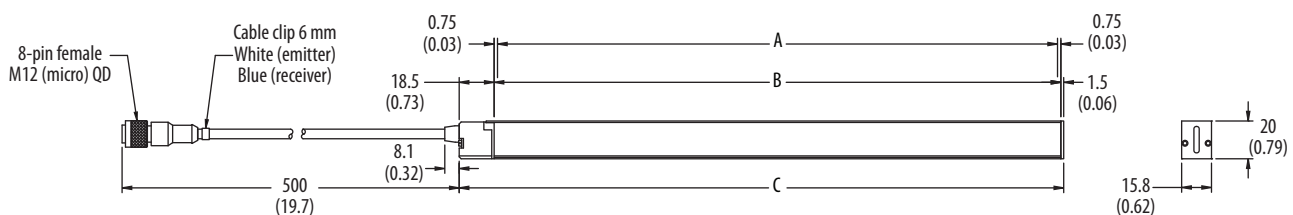

Cascadable Array

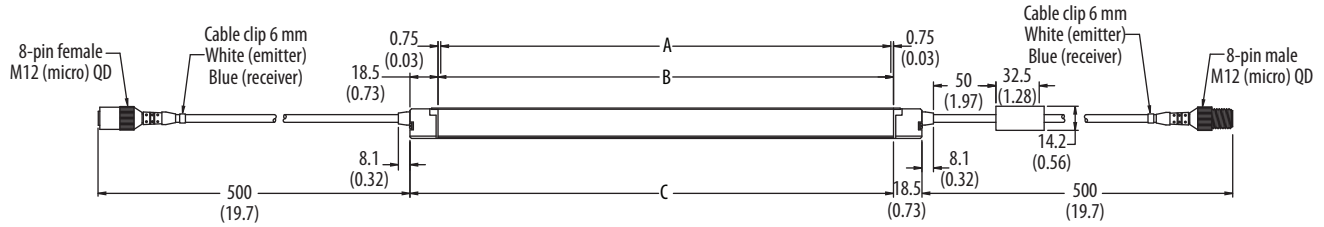

Standard Array

A Sensing Height [mm (in.)]	C Housing Height [mm (in.)]	Beam Spacing [mm (in.)]	No. of Beams	Cat. No.
300 (11.8)	322 (12.7)	25 (0.98)	12	45MLA-AT0300P25
600 (23.6)	622 (24.5)	25 (0.98)	24	45MLA-AT0600P25
900 (35.4)	922 (36.3)	25 (0.98)	36	45MLA-AT0900P25
1200 (47.2)	1222 (48.1)	25 (0.98)	48	45MLA-AT1200P25
300 (11.8)	322 (12.7)	10 (0.39)	30	45MLA-AT0300P10
600 (23.6)	622 (24.5)	10 (0.39)	60	45MLA-AT0600P10
900 (35.4)	922 (36.3)	10 (0.39)	90	45MLA-AT0900P10
1200 (47.2)	1222 (48.1)	10 (0.39)	120	45MLA-AT1200P10

Cascadable Array

A Sensing Height [mm (in.)]	C Housing Height [mm (in.)]	Beam Spacing [mm (in.)]	No. of Beams	Cat. No.
300 (11.8)	339 (13.3)	25 (0.98)	12	45MLA-CT0300P25
600 (23.6)	639 (25.2)	25 (0.98)	24	45MLA-CT0600P25
900 (35.4)	939 (37.0)	25 (0.98)	36	45MLA-CT0900P25
1200 (47.2)	1239 (48.8)	25 (0.98)	48	45MLA-CT1200P25
300 (11.8)	339 (13.3)	10 (0.39)	30	45MLA-CT0300P10
600 (23.6)	639 (25.2)	10 (0.39)	60	45MLA-CT0600P10
900 (35.4)	939 (37.0)	10 (0.39)	90	45MLA-CT0900P10
1200 (47.2)	1239 (48.8)	10 (0.39)	120	45MLA-CT1200P10

IMPORTANT The 45MLA ships as a transmitted beam pair—both the emitter and receiver arrays are in one package. The “T” in the cat. no. represents the transmitted beam pair. For individual parts, replace the “T” with an “E” for emitter or “R” for receiver, for example, 45MLA-AR0300P10.

Rockwell Automation maintains current product environmental information on its website at <http://www.rockwellautomation.com/rockwellautomation/about-us/sustainability-ethics/product-environmental-compliance.page>.

Allen-Bradley, GuardShield, Rockwell Automation, and Rockwell Software are trademarks of Rockwell Automation, Inc. Trademarks not belonging to Rockwell Automation are property of their respective companies.

Rockwell Otomasyon Ticaret A.Ş., Kar Plaza İş Merkezi E Blok Kat:6 34752 İçerenköy, İstanbul, Tel: +90 (216) 5698400

www.rockwellautomation.com

Power, Control and Information Solutions Headquarters

Americas: Rockwell Automation, 1201 South Second Street, Milwaukee, WI 53204-2496 USA, Tel: (1) 414.382.2000, Fax: (1) 414.382.4444
 Europe/Middle East/Africa: Rockwell Automation NV, Pegasus Park, De Kleetlaan 12a, 1831 Diegem, Belgium, Tel: (32) 2 663 0600, Fax: (32) 2 663 0640
 Asia Pacific: Rockwell Automation, Level 14, Core F, Cyberport 3, 100 Cyberport Road, Hong Kong, Tel: (852) 2887 4788, Fax: (852) 2508 1846

Publication 45MLA-IN001C-EN-P - February 2017

10002902576 Ver 00

107 863