

INSTALLATION, OPERATION AND MAINTENANCE MANUAL



CONTROL UNITS TYPE GP04 R
FOR SENSITIVE MATS, EDGES AND
BUMPERS - SENSOR 8,2 K Ω
STATIC OUTPUTS OSSD (PNP)

ISTRUZIONI ORIGINALI

TABLE OF CONTENTS





SYMBOLS : MEANING AND USE	5
INTRODUCTION	6
SAFETY	6
IDENTIFICATION PLATE	7
CE DECLARATION	8
MANUFATURER'S ADDRESS.....	9
OBJECT AND SCOPE OF THE MANUAL.....	9
WARRANTY TERMS	10
WARRANTY	10
LEGISLATIVE REFERENCES	11
IMPORTANT WARNINGS ON SAFETY	12
DESCRIPTION OF THE CONTROL UNIT	13
TECHNICAL SPECIFICATIONS.....	14
IMPROPER USE	15
BLOCK DIAGRAM.....	16
TIME CHART	17
DESCRIPTION OF OPERATION	18
INSTALLATION	19
SAFETY REGULATIONS AND INSTALLATION INSTRUCTIONS.....	19
ADVANTAGES/DISADVANTAGES.....	20
TRANSPORT AND PACKAGING.....	21
GP04 R ENCLOSURE	C21
ENCLOSURE SPECIFICATIONS.....	21
CONNECTION DIAGRAMS	22

ASSEMBLY & DISASSEMBLY	25
WIRING	25
LIGHT INDICATORS.....	26
COMMISSIONING.....	26
FUNCTIONAL TEST	27
CHECKING THE SYSTEM INTEGRITY	28
TROUBLESHOOTING	29
MAINTENANCE	30
DISPOSAL OF CONTROL DEVICE(S).....	30

SYMBOLS: MEANING AND USE

This Manual makes use of symbols in order to draw the reader's attention and focus on very important aspects.

The table below shows the list and describes the meaning of the various symbols used within this Manual.

SYMBOL	MEANING	REMARKS
	Danger	Indicates a hazardous situation which, if not avoided, will result in death or serious injuries of the user.
	Attention	Indicates a hazardous situation which, if not avoided, will result in damage to the machine or to personal belongings of the user.
	Warning Note	Indicates a warning or a note on key functions or useful information.
	Additional information	Text blocs containing additional information are highlighted by this symbol. This information is not directly related to the description of a function or a procedure development. Reminders to another supplementary documentation or other sections of this Manual.

INTRODUCTION

This Manual describes the characteristics, the performance, the transport and installation instructions as well the preventive maintenance instructions for the CONTROL UNIT GP04 R.



This Manual is an integral part of the CONTROL UNIT TYPE GP04 R. It must accompany the control unit along the entire life of the installation.

Keep this Manual and the documentation annexed in a safe and accessible location near the control unit for future consultation. .

It is extremely important that you read and understand the instructions, the safety messages and the regulations contained in this Manual before installing and commissioning the safety control unit.

The installation and maintenance procedures are to be performed by qualified personnel having experience in safety regulations and procedures. The control unit assures protection against the risks which can be eliminating by switching OFF the power supply. The total safety of the machine and the control unit depends on their mutual compatibility and integrity..

Please carefully take into account the risk assessment of the machine to protect in order to choose the best performance level to adopt in conformity with the EN ISO 13849-1 Standard.

The CONTROL UNIT MOD. GP04 R is accompanied by the relevant Declaration of Conformity.

SAFETY

The employer MUST instruct its personnel on the accident risks, the location and functioning of the safety devices as well as on the general rules on accident prevention/protection against risks as provided for in the European Directives and the legislation of the country where the machine is installed.



The operator must be aware of the characteristics and mode of use of the control unit. He/she must have read and understood all parts of this Manual.

All maintenance tasks are to be performed by qualified personnel only.

Tampering with or replacing one or several components capable of modifying the applicability of the control unit without the manufacturer's consent will result in risks of accidents.



Personnel charged with the maintenance work must be aware of the electric risks ((PES, PAV, PEI according to the EN ISO 50110-1 Standard).



IDENTIFICATION PLATE

CE

GP04 R

- **Supply**
- **CH1**
- **CH2**

Modulo di sicurezza

GP04 R MODULO DI SICUREZZA
CATEG. SICUREZZA 3 PLe

Alimentazione : 9 - 13 24 VDC

Uscite di sicurezza : Statiche «Source» 13-12 13 - 16

Tensione Uscita : 24 VDC
 Corrente uscita : 0,4A max per canale
 Tempo risposta : < 10 mS

Uscita segnalazione: 10 - 14
 Max Corrente 110VAC 0,2A / 24 VDC 0,5A

Installare rispettando le indicazioni di impianto

Gamma System srl
Via Torino 24/I 10044 Pianezza (TO)

Tel. +39 011 9682466 www.gamma-system.com e-mail: info@gammasystem.com

<table style="width: 100%; border-collapse: collapse;"> <tr><td style="width: 50%;">+ 24V</td><td style="width: 50%; text-align: right;">9</td></tr> <tr><td>Segnalazione</td><td style="text-align: right;">10</td></tr> <tr><td>Uscita CH1</td><td style="text-align: right;">11</td></tr> <tr><td>Comune</td><td style="text-align: right;">12</td></tr> <tr><td>Segnalazione</td><td style="text-align: right;">13</td></tr> <tr><td>Uscita CH2</td><td style="text-align: right;">14</td></tr> <tr><td></td><td style="text-align: right;">15</td></tr> <tr><td></td><td style="text-align: right;">16</td></tr> </table>	+ 24V	9	Segnalazione	10	Uscita CH1	11	Comune	12	Segnalazione	13	Uscita CH2	14		15		16	<table style="width: 100%; border-collapse: collapse;"> <tr><td style="width: 50%;">1</td><td style="width: 50%;">Reset</td></tr> <tr><td>2</td><td>Auto</td></tr> <tr><td>3</td><td>Mano</td></tr> <tr><td>4</td><td></td></tr> <tr><td>5</td><td></td></tr> <tr><td>6</td><td></td></tr> <tr><td>7</td><td></td></tr> <tr><td>8</td><td></td></tr> </table> <p style="text-align: center; margin-top: 10px;">8,2 Kohm</p>	1	Reset	2	Auto	3	Mano	4		5		6		7		8	
+ 24V	9																																
Segnalazione	10																																
Uscita CH1	11																																
Comune	12																																
Segnalazione	13																																
Uscita CH2	14																																
	15																																
	16																																
1	Reset																																
2	Auto																																
3	Mano																																
4																																	
5																																	
6																																	
7																																	
8																																	

Environmental protections according to the EUROPEAN DIRECTIVE (RAEE)
2012/19/UE

The product conforms to the Directive
2011/65/UE

Fig. 1-1 Identification plate

EC DECLARATION OF CONFORMITY

DICHIARAZIONE CE DI CONFORMITÀ

EC DECLARATION OF CONFORMITY

(lingua originale ITALIANO)		(translation from the original language:
Noi	GAMMA SYSTEM S.R.L. Via Torino, 24/I 10040 PIANEZZA (TO)-Italy	We
in qualità di costruttore e persona giuridica stabilita nella comunità e autorizzata a costituire il fascicolo tecnico, dichiariamo sotto la nostra esclusiva responsabilità che il componente di sicurezza : UNITA' DI COMANDO PER TAPPETI, BORDI E PARAURTI SENSIBILI ALLA PRESSIONE MODELLI: GP04 R e GP04 T risponde alle disposizioni previste dalle direttive alle quali questa dichiarazione si riferisce:		as manufacturer and person authorised to compile the technical file and established in the Community, declare on our sole responsibility that the safety component: CONTROL DEVICE FOR SENSITIVE MATS, EDGES AND BUMPERSMOD. GP04 R and GP04 T meets the requirements of the following standard directives:
2006/42/CE - 2014/30/UE 2012/19/UE (RAEE) - 2011/65/UE (ROHS) - Regulation (EC) n°1907/2006 (REACH)		
Sono state utilizzate le seguenti norme	The following standards have been applied:	
EN ISO 13849-1 ; EN ISO 13856-1 ; EN ISO 13856-2 ; EN ISO 13856-3 EN ISO 12100 ; EN 60204-1		
CERTIFICATO DI ESAME "CE" DI TIPO	"EC" TYPE EXAMINATION CERTIFICATE	
N° 20CMAC0023		
EMESSO DALL'ORGANISMO NOTIFICATO	ISSUED BY THE NOTIFIED BODY:	
I.C.E.P.I S.p.a Via Belizzi, 31 - 29122 PIACENZA- Italia Numero identificazione 0066 / Identification number 0066		
Luogo e data: <i>Place and Date:</i> <i>Pianezza 29/07/2020</i>	Amministratore Delegato Managing Director  Maurizio Valentini	

Fig. 1-2 EC Declaration of Conformity

MANUFACTURER'S ADDRESS

GAMMA SYSTEM S.r.l, is at your disposal for supplying any type of information on the use, installation and maintenance of the control units.

The Customer/User must submit the requests for information in a clear and unambiguous manner to the After-Sales Service for intervention at the Customer/User's premises. Any requests of clarification concerning the technical aspects of this document are to be addressed to:



GAMMA SYSTEM S.r.l.
10044 - Pianezza - TO
Via Torino, 24/I _ Italy
Tel. +39 011 968 24 66 a.r.
Fax +39 011 967 42 11
e-mail: info@gammasystem.com
www.gammasystem.com

OBJECT AND SCOPE OF THE MANUAL

This Manual is intended for installers and users of the **CONTROL UNIT GP04 R**. It supplies the technical characteristics of the system, describes the different functional groups as well as the main procedures for use and information required to perform the maintenance tasks.

This manual is intended for technical personnel with good knowledge of processing techniques, and of mechanical and electrical design. It is also intended for operators charged with machine exploitation and maintenance personnel .

This Manual is an integral part of the machine and contains useful information for personnel charged with machine exploitation/maintenance in order to operate in safety and assure perfect efficiency during the entire useful life of the machine.

The machine must be operated in adequate premises in conformity with the current safety specifications.



WARRANTY TERMS

GAMMA SYSTEM S.r.l. warrants its products against any defects in material and workmanship provided that they are used under the prescribed and normal conditions indicated in the Manual.

The warranty covers the GAMMA SYSTEM safety system consisting of the sensor (sensitive mat, edge, bumper) and the control unit.

WARRANTY

The warranty covers the defects due to design, materials and/or workmanship and covers 24 (twenty-four) months from the date of invoice.

In the absence of an invoice referring to Gamma System, the warranty period of 24 months starts from the fabrication date. For the verification of the applicability, the date when the customer communicates the defect will prevail.

The warranty is valid under these conditions:

- If a fault occurs, the customer must inform, in writing, Gamma System, detailing the failure and the product considered defective. In order to make use of the warranty, the communication of the defect must be sent within the warranty period

The return of faulty products must be agreed upon with Gamma System which will issue a special code number for returning the goods. This code/number is to be indicated in the transport document accompanying the goods. Components covered by warranty will be repaired or replaced free of charge by Gamma System.

- Gamma System does not undertake to remedy faults under warranty if the following conditions occur (directly or indirectly):

- improper use of the control unit
- non-observance of the use instructions
- carelessness, incompetence, wrong maintenance
- repair, modifications, adjustments not performed by Gamma System personnel, tampering with the control units, etc...
- accidents or impacts (also due to transport or causes of force majeure)
- other causes independent of Gamma System

The warranty covers the free of charge replacement of faulty components. In severe cases, sending of technical personnel to the site is at the discretion of GAMMA SYSTEM.

As for transport costs of defective material under warranty, the following conditions shall be applied:

- from Customer to Gamma System: at Customer's charge
- from Gamma System to Customer: at Gamma System's charge

Transports by means of express courier or to an address other than that of the Customer to whom Gamma System has invoiced the goods, will in any case be at Customer's charge.

Gamma System disclaims all other warranties or rights other than those made herein; in no event can claims for compensation be filed for expenses, down-time, lost production or other factors or circumstances, arising directly or indirectly from and in any way connected with the failure of the product or one of its parts.

STANDARDS

The safety component named

CONTROL UNIT TYPE: GP04 R

Manufactured by:

GAMMA SYSTEM S.R.L.-Via Torino 24 I

10044 PIANEZZA (TORINO) -ITALY

Has been designed and manufactured respecting the essential health and safety requirements of persons. In a special way, the design and manufacture requirements set out in the Machine Directive 2006/42/EC and in the Directive “Electromagnetic Compatibility” 2014/30/UE have been taken into account as well as the requirements of the harmonized standard EN ISO 12100 regarding the risk prevention, the Standards and the technical national specifications in force, taking into account the technological level existing at the time of construction and the technical and economical imperatives.

GAMMA SYSTEM CONTROL UNIT also conceptually meets the clarifications indicated in the following Standards:

EN 13856-1:2013	Pressure-sensitive protective devices - Part 1: General principles for design and testing of pressure-sensitive mats and pressure-sensitive floors.
EN 13856-2:2013	Pressure-sensitive protective devices - Part 2: General principles for design and testing of pressure-sensitive edges and pressure-sensitive bars
EN 13856-3:2013	Pressure-sensitive protective devices - Part 3: General principles for design and testing of pressure-sensitive bumpers, plates, wires and similar devices
EN ISO 13849-1:2015	Safety of machinery - Safety-related parts of control systems - Part 1: General principles for design
EN ISO 13849-2:2013	Safety of machinery - Safety-related parts of control systems - Part 2: Validation
EN 60204-1:2018	Electrical equipment of machines - Part 1: General requirements
EN 60529:1991/A2:2013/AC:2019	Degree of protection provided by enclosures (IP code)
<i>Fundamental climatic and mechanical resistance tests:</i>	
EN 60068-2-78: 2013	Environmental testing - Part 2-78: Tests - Test Cab: Damp heat, steady state
EN 60068-2-6:2008	Environmental testing - Part 2-6: Tests - Test Fc: Vibration (sinusoidal)
EN 60068-2-14:2009	Environmental testing - Part 2-14: Tests - Test N: Change of temperature
<i>Other European Directives</i>	
2012/19/UE	(RAEE)
2011/65/UE	(ROHS)

Unless otherwise indicated, references to Standards refer to the last issue.



IMPORTANT WARNINGS ON SAFETY

This Manual is intended for qualified, technical personnel charged with installation.

GAMMA SYSTEM components are not intended for use in potentially explosive atmospheres.

The control unit, in association with the sensor, is a safety system used for detecting the presence of persons in areas which can become a source of danger with risk of personal injuries.

To make sure that the application of a safety component for protecting a machine or an installation, meets the current Standards, it is necessary to assess the risk level of the machine/installation as well as its compatibility with the performance level declared by GAMMA SYSTEM (in conformity with EN ISO 13849-1 Standard). For safety components used to protect the machines the performance level is defined by C-type Standards or by the risk assessment performed by the machine manufacturer. The manufacturer is responsible for determining the performance level of the entire control circuit.

Other fundamental elements are the installation, maintenance and verification of good operation of the safety component. These evaluations are the sole responsibility of the machine manufacturer.

The additional requirements indicated below must be satisfied before using the control unit:

- The machine to be protected by the control unit must be capable of stopping at any point of its cycle and machine movements it must be prevented from restarting until the hazardous situation persists and has not been eliminated.
- If the control unit provides for the automatic reset, this function is entrusted to the machine manufacturer.
- When the control unit is used as a safety device, the machine manufacturer is responsible for making sure that all requirements, rules, codes and applicable legislation are fully met in compliance with current regulations.
- Test procedure must be carried out during the installation phase and after any maintenance work and modifications performed on the machine. Test procedure is described in this Manual.
- Electrical wiring must be made and installed in compliance with the local regulations and electrical standards in force.
- The user must follow all procedures described in this Manual in order to ensure correct operation of the control unit.
- The employer is responsible for the selection and instruction of personnel charged with the use, maintenance of the machine and its relevant safety system. The machine user shall immediately report any malfunction of the machine, tools, equipment and safety devices. Do not operate the machine if the safety device(s) is (are) defective.

DESCRIPTION OF THE CONTROL UNIT

The **GP04 R** control unit is a safety device used to control sensitive mats, edges and bumpers through a 2-wire, 8,2 K Ω sensor with STATIC OUTPUTS OF OSSD (PNP) SOURCE TYPE. Its architecture is based exclusively on discreet, electronic components and electromechanical components. No programmable logic components are used.



The use of the safety control unit not in compliance with its usage destination (described in this Manual) is strictly forbidden.

Technical data and drawings contained in this Manual may vary without prior notice. Please always refer to the last update(s) of technical drawings and diagrams.

TECHNICAL SPECIFICATIONS

Classification	GP04R	
Reference Standard	EN ISO 13849-1, EN ISO 13856 (parts 1,2,3)	
PL	e ⁽¹⁾	
Category	3 ⁽¹⁾	
DC [%]	86,2	
PFH _D (1/h)	5*10 ⁻⁸	
Reset	Manual/Automatic	
Categories of use	DC13	
Electrical data		
Power supply	24 VDC ± 10%	
Current consumption with sensor activated(24VDC)	15 mA	
Current consumption with sensor reset (24VDC)	15 mA	
Inputs		
Detection of short-circuited inputs	YES	
Detection of input connection interruption	YES	
Max length of connecting cables	100 m	
Min section of connecting cables	0,35 mm ² (1 mm ² for cable length >20 m)	
Max resistance of activated sensor	100 ohm	
Voltage applied to inputs	24 VDC	
Max current (peak)	2 mA	
Safety outputs		
Number of safety outputs	2	
Max switchable voltage [VDC]	24	
Max switchable current DC13 VDC [A]	0,4	
Max switchable capacity in AC [VA]	Not allowed	
Type of Outputs mode	Static	
Type of Outputs mode	PNP Source	
Rated Power supply	VDC	24
Rated power DC [W]	0,25	
ON delay time (reset)	<10ms	
OFF delay time (Intervention)	<10 ms	
Protection against over-currents ⁽²⁾	1 A quick	
Signaling outputs		
Number of signaling outputs	1	
Max operating voltage	VAC	125
	VDC	30
Max current 110VAC	0,2 A	
Max current 24VDC	0.5 A	
Environmental characteristics		
Operating temperature [°C]	-10 / +55	
Storage temperature [°C]	-20 / +70	
Max relative humidity	85%	
Degree of protection - terminals/casing	IP20/IP30	
Vibrations (frequency/amplitude)	10-55 Hz/0,15 mm	
Electromagnetic environment (immunity/emission)	Industrial/residential	
Altitude a.s.l.	Max 1000 m	
Overcurrent category/Degree of pollution	III/2	
Dimensions		
Width [mm]	22,5	
Height [mm]	56,4	
Depth [mm]	98	
Weight [g]	60	
Material of casing	PA - UL94V0	
Installation	On Omega rail	

⁽¹⁾ Provided that conditions indicated in chapter "INSTALLATION" page 18 are met.

⁽²⁾ Power supply shall be applied through a stabilized power feeder or equivalent systems capable of preventing the current pulses on the control unit power supply and temporary interruption of voltage (see. EN 60204-1 Standard, point 4.3).

IMPROPER USE

The control unit described in this Manual has been designed and manufactured in order to control sensitive safety mats, edges and bumpers with a 2-wire sensor - resistance 8,2 K Ω .



The use of the installation for purposes other than those described in this Manual is considered an IMPROPER/INCORRECT USE. GAMMA SYSTEM shall not be held responsible for damage to persons or property in case of damage due to improper/incorrect use. Improper/incorrect use of the control unit will void any form and type of warranty.

The manufacturer will not be held responsible for damage and/or malfunctioning in case of tampering with the control unit or non-authorized modifications or maintenance work performed by non-authorized personnel.

DO NOT USE the control unit:

- on a machine/installation with inadequate stoppage time or inadequate control mechanisms;
- in an environment which can degrade the good working of the control unit (e.g.: environments where corrosive, chemical agents are present);
- to start the machine motion;
- Outside the temperature range: -10°C et + 55°C
- In zones classified as potentially explosive areas

BLOCK DIAGRAM

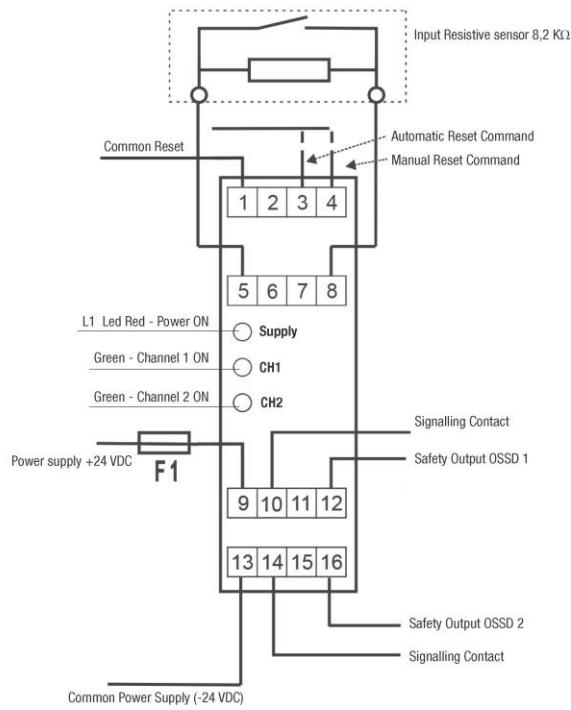
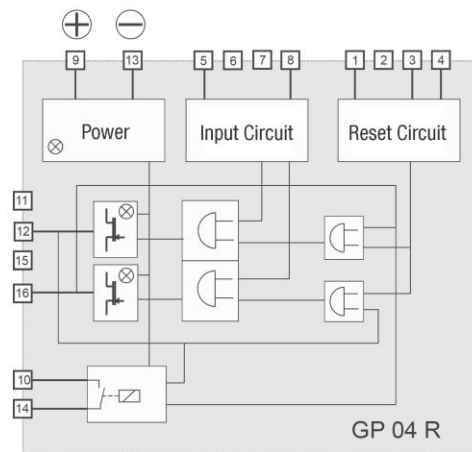

Note F1: F1 Protection fuse 1 A fast

Connection	
1	Common Reset
3	Automatic Reset Command
4	Manual Reset Command
5-8	Input Resistive sensor 8,2 KΩ
6-7	//
9	Power supply +24 VDC
10	Signalling Contact
12	Safety Output OSSD 1
13	Common Power Supply (-24 VDC)
14	Signalling Contact
11-15	//
16	Safety Output OSSD 2
Signalling LED's	
L1 Supply	Red – Power ON
L2 CH1	Green – Channel 1 ON
L3 CH2	Green – Channel 2 ON



Fig. 1-3 Block diagram

TIME CHART

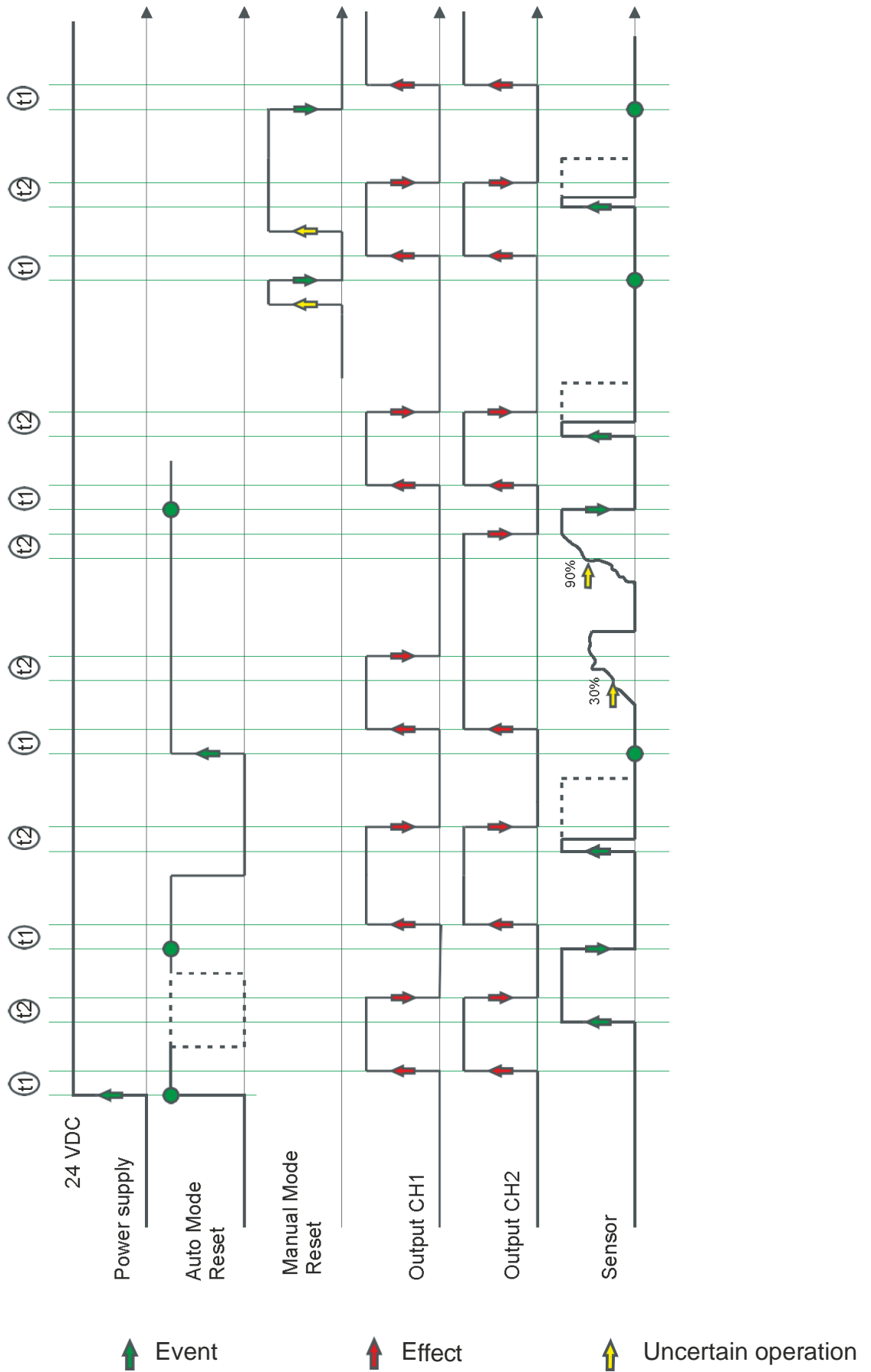

Fig. 1-4 Time diagram

OPERATION DESCRIPTION

For the sake of simplicity, the sensor (sensitive mat, edge or bumper) is considered as a unique NO contact which makes when activated.



RESET function set on AUTOMATIC mode (contact closed between terminals 1 - 3)

When the control unit is 24 VDC power supplied, positive on terminal 9 and negative on terminal 13, the red Led "Supply" goes ON. Once the activation time t_1 has elapsed, if the safety sensor (sensitive edge, mat, bumper) is not pressed / activated, the safety outputs 12 and 16 switch to active status (HIGH) – green LEDs "CH1" and "CH2" are ON - thereby applying +24V voltage, measured between the terminals 12-13 (CH1) and 16-13 (CH2). If the safety sensor (sensitive edge, mat, bumper) is pressed or interrupted, once time t_2 has elapsed, the safety outputs 12 and 16 switch to non-active status (LOW) – green LEDs "CH1" and "CH2" go OFF and +24V voltage is removed, measured between terminals 12-13 (CH1) and 16-13 (CH2).

When the safety sensor (sensitive edge, mat, bumper) is released (not activated), because the Automatic RESET function is active, once the activation time t_1 has elapsed, the safety outputs 12 and 16 go back to the active status (HIGH) – green LEDs "CH1" and "CH2" go ON - thereby applying +24V voltage measured between the terminals 12-13 (CH1) and 16-13 (CH2).

If closing of the safety sensor (sensitive edge, mat, bumper) is uncertain (e.g. pressure on it is too low), once the time t_2 has elapsed, one of the two safety outputs (output 12 or 16) switch to non-active status (LOW) and one of the corresponding green LEDs "CH1" or "CH2" go OFF, thereby ENSURING the safety function

When the sensor is not pressed / activated and the safety outputs 12 and 16 are active, the green LEDs "CH1" and "CH2" are ON, possible breaks / makes of the reset contact do not modify the status of these outputs (ALWAYS ACTIVE)



RESET function set on MANUAL Mode (contact closed between terminals 1 - 4)

When the control device is 24 VDC power supplied, with positive on terminal 9 and negative on terminal 13, the red Led "Supply" goes ON. Until the RESET command is not applied, the safety outputs 12 and 16 stay in the NON-active status (LOW) with green LEDs "CH1" and "CH2" OFF. When after giving the RESET command (close terminals 1 – 4), it is released (open contact between terminals 1 and 4), after the activation time t_1 has elapsed, if the safety sensor (sensitive edge, mat, bumper) is not pressed / activated, the safety outputs 12 and 16 switch to the active status (HIGH) – green LEDs "CH1" and "CH2" ON - thereby applying +24V voltage measured between terminals 12-13 (CH1) and 16-13 (CH2). If the safety sensor (sensitive edge, mat, bumper) is pressed or interrupted, when time t_2 has elapsed, the safety outputs 12 and 16 switch to the non-active status (LOW), the green LEDs "CH1" and "CH2" go OFF and +24V voltage, measured between terminals 12-13 (CH1) and 16-13 (CH2) is removed..

With the safety sensor (sensitive edge, mat, bumper) not activated, the RESET function **MUST BE REACTIVATED** (closing of terminals 1 -4) and then RELEASED (opening of terminals 1 – 4) in order to reactivate the safety outputs. Once the activation time t_1 has elapsed, the safety outputs 12 and 16 go back to the active status (HIGH) – green LEDs "CH1" and "CH2" ON - thereby applying +24 V voltage, measured between terminals 12-13 (CH1) and 16-13 (CH2).

If closing of the safety sensor (sensitive edge, mat, bumper) is uncertain (e.g. pressure on it is too low), after time t_2 has elapsed, one of the two safety outputs (output 12 or 16) switches to the non-active status (LOW) and one of the corresponding green LEDs "CH1" or "CH2" goes OFF, thereby ENSURING the safety function.

INSTALLATION

SAFETY REGULATIONS AND INSTALLATION INSTRUCTIONS



DANGER! RISK OF DEATH, PERSONAL INJURIES OR DAMAGE TO THE EQUIPMENT!

Depending on the application, the wrong use of the device may result in serious risks for the safety and health of the user or damage the equipment. Always respect all the safety rules and warnings indicated in this Manual.

Read and understand this Manual before commencing any operations on the control unit(s)..

The GP04 R is a safety device used to control 2-wire, pressure sensitive sensors – resistor 8,2 kΩ. It is made from an IP30 plastic casing with DIN connection and is intended to be installed inside an enclosure (e.g.: electrical cabinet) providing IP54 degree of protection (minimum)

The control unit must be powered via a power supply circuit in compliance with EN 60204-1:2006, point 6.4 (PELV) Standard.

The control unit architecture for category 3 is such if the two one-channel, static outputs (terminals 12 and 16) are handled by a processing unit (e.g. a safety PLC) in PL capable of monitoring the outputs. Alternatively, the architecture for category 3 may be implemented by connecting each output to a relay in compliance with the requirements of EN 61810-3 Standard,; in this case, the NO contacts must be connected in series in order to implement the function in a redundant way and the NC contacts must be connected in series and inserted into the feedback circuit of the control unit (terminals 1 and 3 or 4, depending on the reset mode) in order to provide the correct diagnostic coverage.

In this case, special attention shall be paid to current consumption of loads on static outputs and protection systems against overvoltage generated by inductive loads during transients are to be put in place.

In fact, when removing power supply used to energize inductive-type loads such as valve solenoids, contactors or relays, a reverse voltage will be generated because of the characteristics of this type of devices. This reverse voltage may be greater than the original supply voltage used to power supply the device (three times greater or even more, depending on the inductive load).

It is therefore important to ensure that the outputs of any equipment used to pilot these types of inductive loads are adequately protected. This will prevent damage and faults to the output used to pilot the load.

The outputs can be used to pilot inductive loads such as valve solenoids, contactors or relays. Due to these high reverse voltages generated at shutdown, it is therefore of paramount importance to make sure that adequate protection (suppressor) is installed directly on each of these devices connected to the output of the control unit. This will prevent the occurrence of damage and possible failures. This precaution ensures that the energy of the inductive load on shutdown is dissipated through the suppressor instead of the static output (MOSFET).

Different types of protection are available:

- RC (resistor/capacitor)
- Flyback diode
- Varistor

ADVANTAGES/DISADVANTAGES

RC protective modules can also interfere with hardware controls performed by the control unit on the outputs by signaling wrong situations of error.

The use of diode-type protective modules may also affect the performance of intervention times. This may result in the increase of stoppage times if compared with protection via a varistor.

Varistor: offers response time and suppressing capacities for voltages and transients generated which are greater than the other protection solutions. Furthermore, varistor provides protection for valves with integrated electronics and reduces electromagnetic disturbances and radio-frequency. But it is necessary to check that the blocking voltage is really lower than maximum reverse voltage that Mosfet can withstand.

The protection of the suppressor installed on the inductive load MUST be capable of blocking this reverse voltage at 50V or even less. The installation of suppressors which block the reverse voltage greater than 50 V or failure to install suppressors could result in damage to the output of the control unit and also damage because of the energy which is dissipated through the output device instead of the suppressor installed on the valve/relay coil.

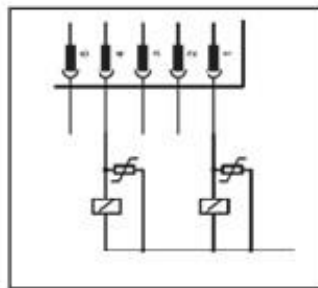

Fig. 1-5 Connections of protective modules

The protection MUST ensure that over-voltage is lower than maximum reverse voltage of the Mosfet and must be capable of ensuring correct operation within the “SOA” (Safe OPERATION Area) of the component (see picture below) also in function of the duration of over-voltage peak.

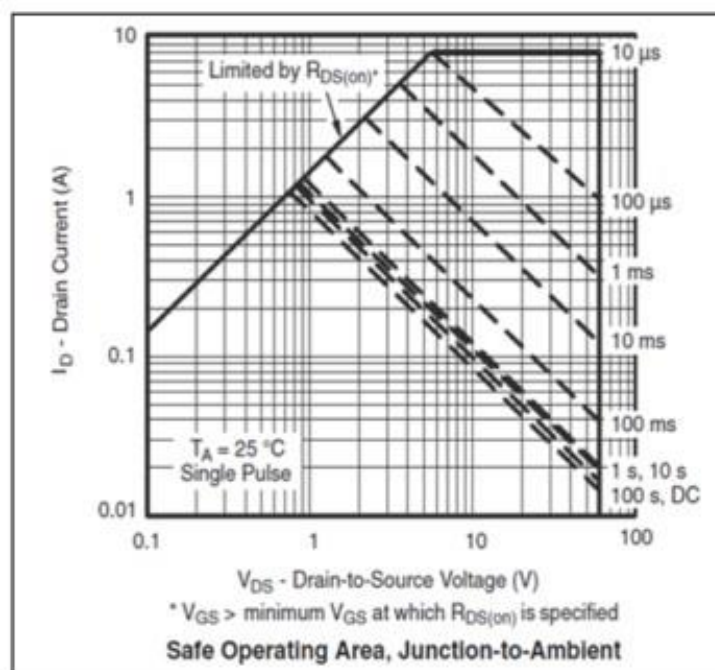

Fig. 1-6 Safe OPERATION Area

TRANSPORT AND PACKAGING



ATTENTION! Pay maximum attention while handling and transporting the control unit.

Packaging shall be in compliance with the means used for transport and with Standards provided for by legislation and/or by the specific requirements of the country in which the device is used.

Upon delivery, carefully inspect the package to make sure it is not damaged. If you note any damage, file a claim with the shipping company and notify GAMMA SYSTEM.

Pay maximum attention not to damage the content while opening the package.

GP04 R CONTROL UNIT ENCLOSURE

The GP04 R control unit is housed in a plastic enclosure destined to be installed on a DIN Rail.

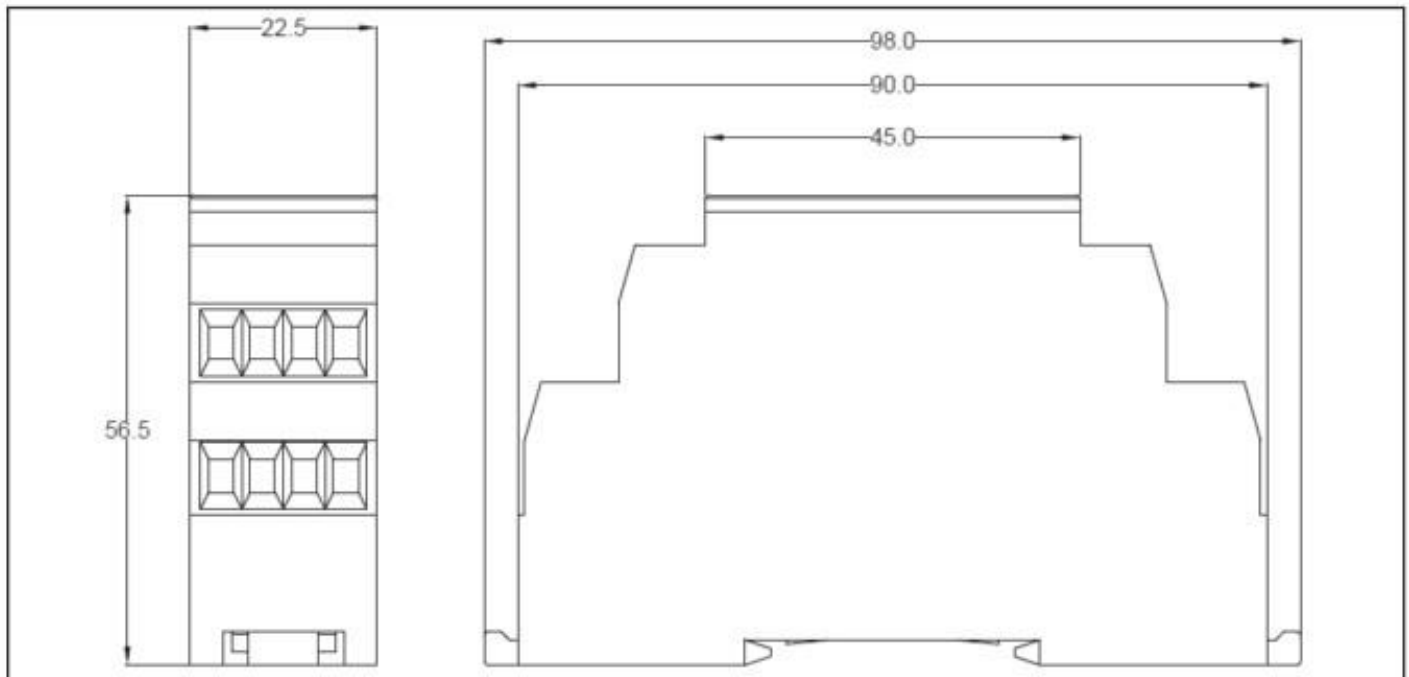

Fig. 1-7 GP04 R enclosure

ENCLOSURE CHARACTERISTICS

Enclosure material	PA-UL940V0
Installation	on Omega rail

WIRING DIAGRAMS



ATTENTION!

AUTOMATIC RESET: Make jumpers and/or insert the series of feedback contacts between terminals 1 and 3.

MANUAL RESET: Connect the NO Reset contact in series with the feedback contacts between terminals 1 and 4.

A signaling contact is planned (NO contact between terminals 10-14) WHICH CLOSSES WHEN BOTH THE "CH1" and "CH2" SAFETY OUTPUTS are active (Green LEDs ON).

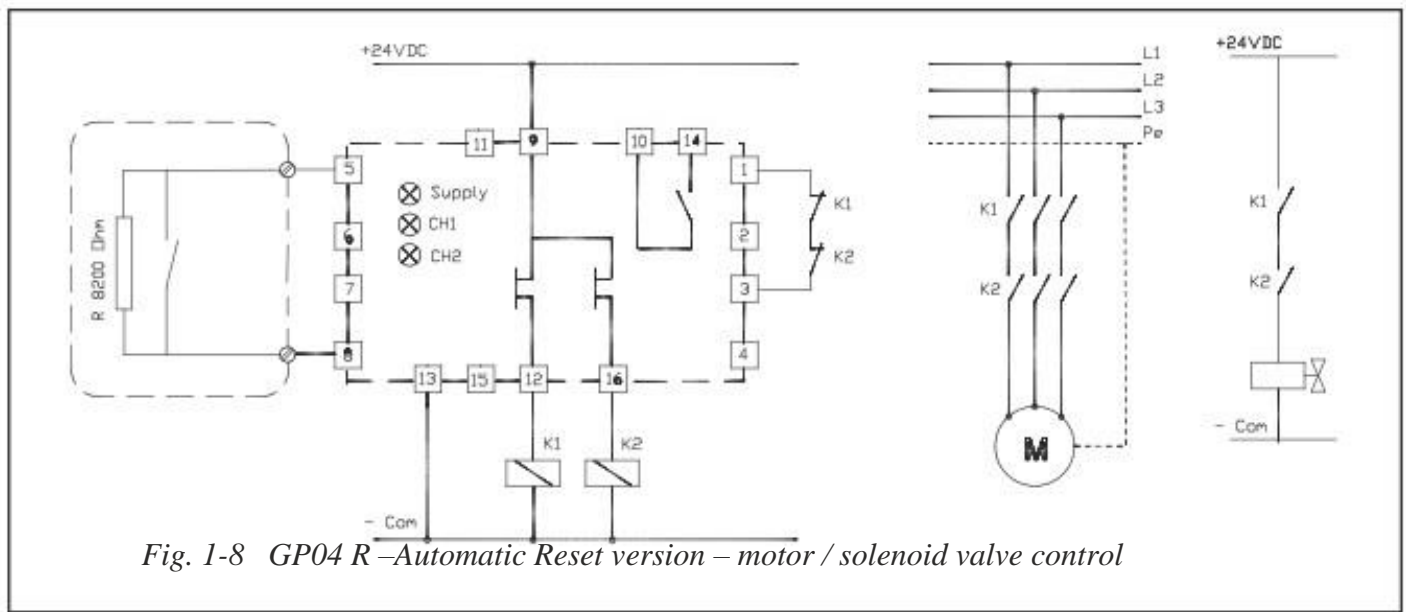

Fig. 1-8 GP04 R – Automatic Reset version – motor / solenoid valve control

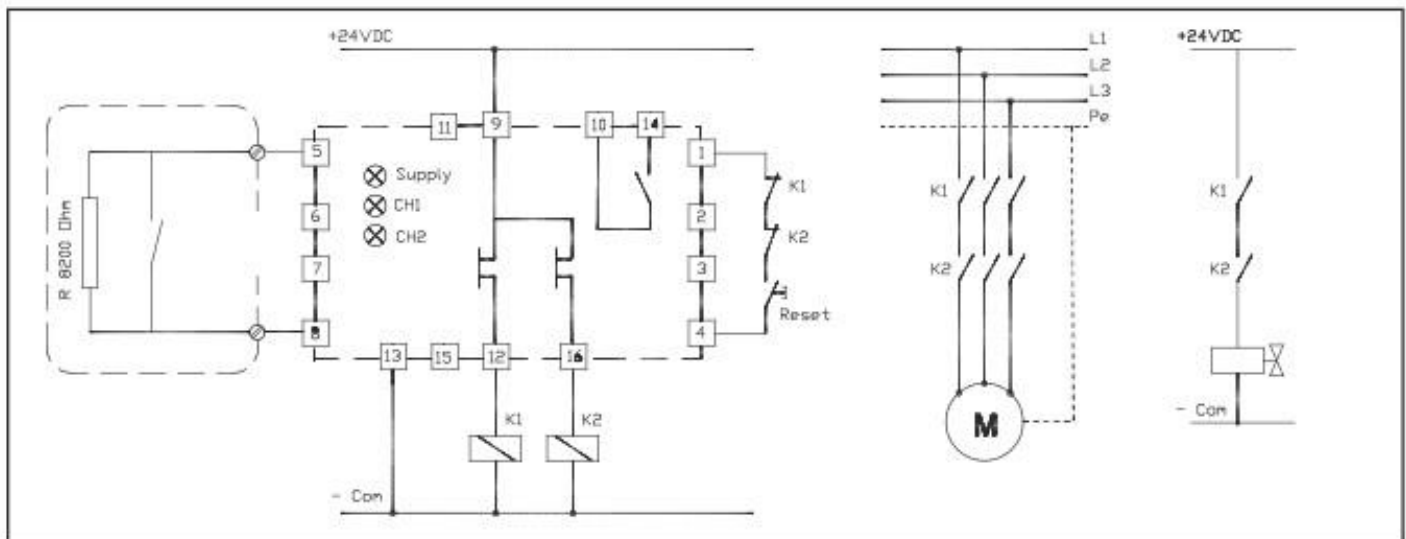

Fig. 1-9 GP04 R – Manual Reset version – motor / solenoid valve control

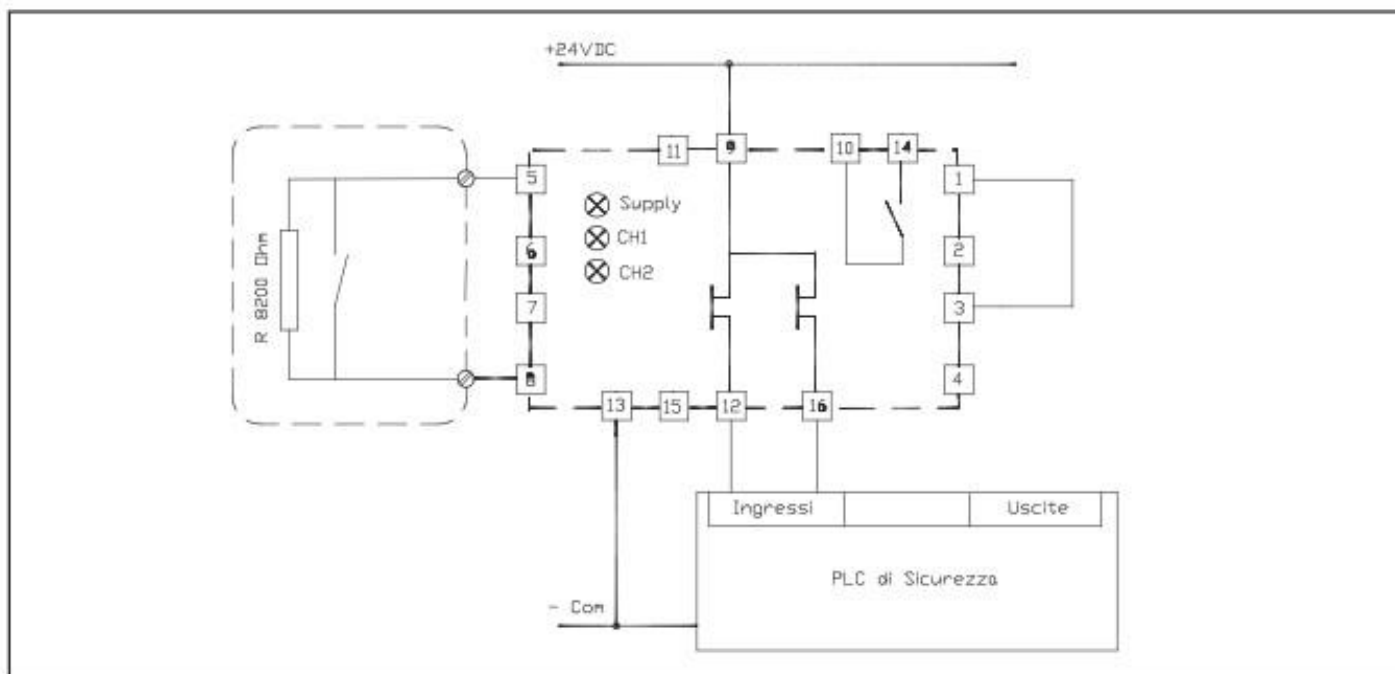

Fig. 1-10 GP04 R –Automatic Reset version – PLC Control

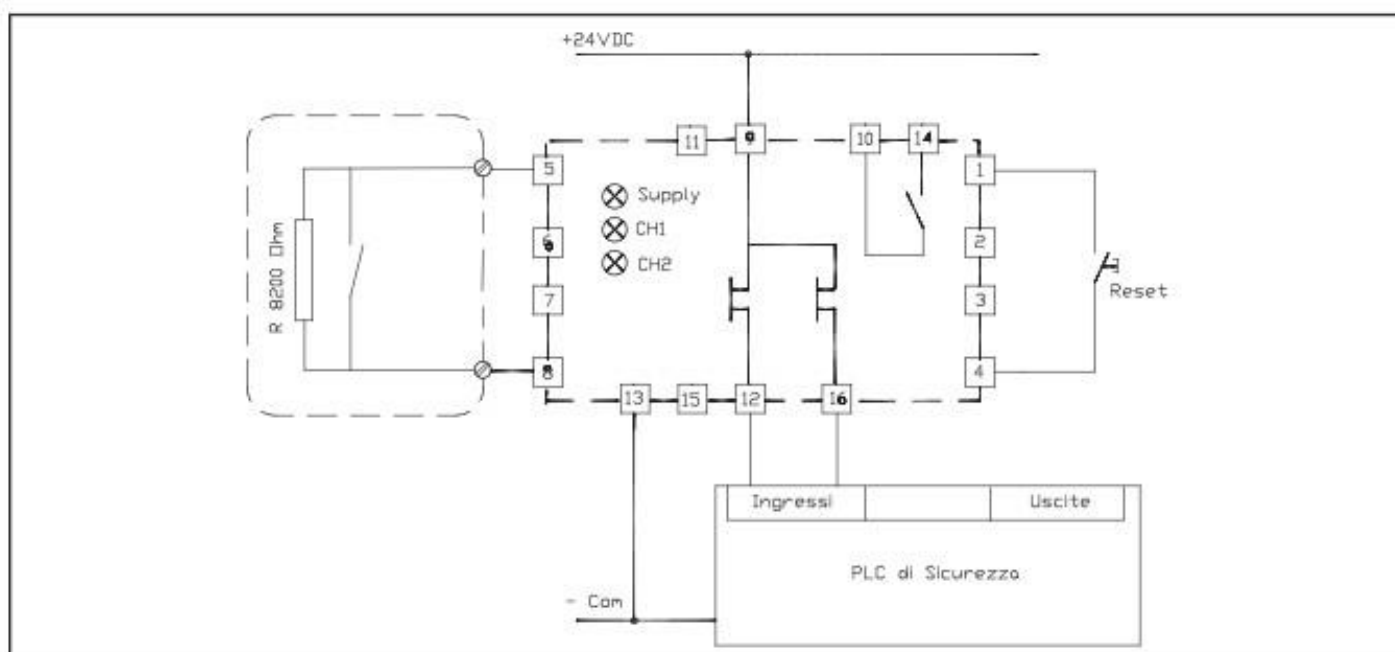

Fig. 1-11 GP04 R – Manual Reset version – PLC control

ASSEMBLY AND DISASSEMBLY

Mount the device on a 35 mm DIN rail in compliance with the EN ISO 60715 Standard.. To remove the device, use a screwdriver to release the attachment.

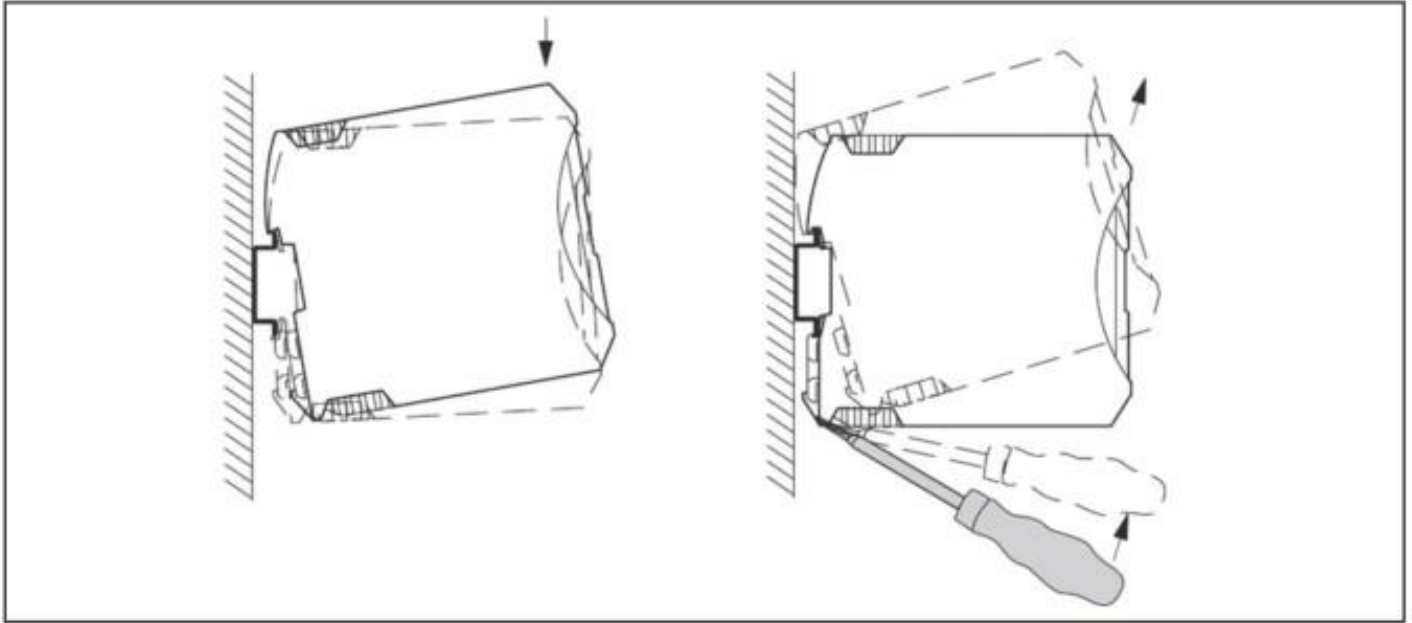

Fig. 1-12 Mounting the enclosure

WIRING

Use a screwdriver to connect the cables to terminals. Use cables of 0,35 - 2,5 mm² - AWG 14 cross section and tighten to 0,5 Nm. torque

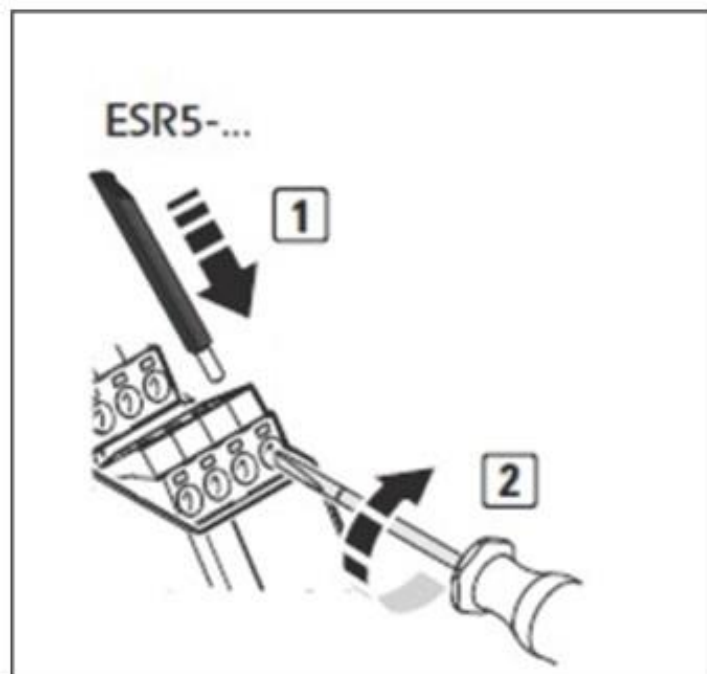

Fig. 1-13 Wiring

LIGHT INDICATORS

Depending on the device status, here below you find the meaning of the lights indicators:

RED LED "SUPPLY" : POWER SUPPLY

GREEN LED "CH1" : SAFETY 1 OUTPUT

GREEN LED "CH2" : SAFETY 2 OUTPUT

LIGHT INDICATORS (LEDs)	CONTROL UNIT POWERED AND RESET	SENSOR NOT ACTIVATED	SENSOR ACTIVATED
SUPPLY	ON	ON	ON
CH1	ON	ON	OFF
CH2	ON	ON	OFF

COMMISSIONING



WARNING: the entire safety of the machine and of the corresponding safety devices depends on the quality, reliability and correct installation of the relevant interfaces.

Once the installation is terminated, following the assembly instructions indicated in this Manual, and before commissioning the machine for production cycle and after performing the periodical checks (monthly checks), the personnel charged with the exploitation must verify that the points of the integrity control (see list below) have been satisfied in order to ensure the safety of the machine/installation.

FUNCTIONAL TEST



The activation of the sensor during a hazardous situation of the working cycle must stop the movements of all dangerous parts/components or, where appropriate, trigger a safety situation. The repeated motion of all hazardous parts must be prevented unless the safety function has been re-established.

OPERATION	EQUIPMENT REQUIRED	TYPE OF OPERATION	LED STATUS	SAFETY OUTPUTS STATUS	POSSIBLE FAILURE IF LED SIGNAL IS OTHER THAN THE CORRECT ONE
1	Screwdriver, Ø 3,5	Disconnect the 2 wires of the sensor (5-8) from module	Red LED "SUPPLY": OFF Green LED "CH1": OFF Green LED "CH2": OFF	NOT ACTIVE	
2	Screwdriver, Ø 3,5	Mount a new resistor - 8,2 kΩ- min. power 0,5 W - between terminals 5-8	Red LED "SUPPLY": OFF Green LED "CH1": OFF Green LED "CH2": OFF	NOT ACTIVE	
3	-	Power supply the module (24V DC). Make sure to respect polarity	Red LED "SUPPLY": ON Green LED "CH1": OFF Green LED "CH2": OFF	NOT ACTIVE	Red LED "SUPPLY": OFF. Power failure or reversed polarity
4	-	Press the Reset button of the machine	Red LED "SUPPLY": ON Green LED "CH1": ON Green LED "CH2": ON	ACTIVE	Green LEDs "CH1" and/or "CH2" OFF. Control unit faulty or jumpers incorrectly connected.
5	-	Prepare 1 jumper – 5 cm in length – and simulate the activation of the sensor between terminals 5-8	Red LED "SUPPLY": ON Green LED "CH1": OFF Green LED "CH2": OFF	NOT ACTIVE	Green LEDs "CH1" and/or "CH2" ON. Control unit faulty or jumpers incorrectly connected
6	-	Remove jumper between terminals 5-8 and press Reset	Red LED "SUPPLY": ON Green LED "CH1": ON Green LED "CH2": ON.	ACTIVE	Green LEDs "CH1" and/or "CH2" OFF. Control unit or jumpers incorrectly connected

! SYSTEM INTEGRITY CHECK

- Inspect the machine controls and the connection to the device to ensure that no modifications capable of adversely affecting the system have been carried out and check that authorized modifications have been recorded.
- Check the efficiency with powered device and machine idle.
- Where the Reset function is planned, check that the restarting of machine cannot be done until the system has been reset.
- Check that the device is suitable for the environmental conditions
- Check that the device is firmly secured;
- Check the rated values and the characteristics of all inputs/outputs, e.g.: rated values of fuses;
- Check that when power supply is shutdown, all hazardous movements of the machine are prevented. Dangerous parts of the machine shall be reactivated only when the safety function has been re-established;
- Interface between the machine and the control unit is of paramount importance for safety. Make sure that all the machine parts, including the safety device/s the control circuit as well the safety device connections are in compliance with the risk assessment results and with the categories (in compliance with EN ISO 13849-1:2008 established in the relevant legislation
- If installed, check the lock-off devices depending on the requirements indicated at point 5.2.5 of EN ISO 13849-1:2008. Standard.
- Check that all light indicators operate correctly..



TROUBLESHOOTING AND POSSIBLE REMEDIES

Table below shows the most common faults which can occur on the control unit and gives a list of causes and remedies.

If a failure occurs, check possible cause indicated in the table below, All operations must be performed by qualified personnel only.

If No qualified personnel is available, do not hesitate to contact GAMMA SYSTEM.

GP04 R LIGHT INDICATORS	CAUSE	REMEDY
Red LED "SUPPLY": OFF	Power supply failure	Check connection on electrical panel
	Reversed polarity	Check and re-establish correct polarity
	External protection fuse is broken	Check and replace the fuse (if necessary)
	Led burned out	Replace module and send to Gamma System
	Power cable not correctly connected to terminal	Tighten the screws with wire inserted in terminal
Green LED "CH1" and/or "CH2": OFF	Sensor activated	Remove possible weights and deformations caused by the floor or by foreign bodies under the bumper
	Internal sensor faulty	Replace the sensor and send to Gamma System for repair
	Temporary block of the module	Activate the sensor and reset the Reset button
	Internal fault of the control unit	Replace the control unit and send to Gamma System
	Circuit of sensor connection broken	Check connections
	Inner circuit of sensor broken	Replace the sensor and send the faulty one to Gamma System
Green LEDs "CH1" and/or "CH2": ON and never go OFF	Sensor is faulty	Check sensor and/or send it to Gamma System
	Short-circuited output on control unit	Replace the control unit and send to Gamma System

Read and fully understand all the instructions for use provided in this Manual before commencing any maintenance work on the equipment. Tasks requiring specific technical experience and/or specific competence must be performed by qualified and trained personnel only, meaning by GAMMA SYSTEM technical personnel.

After any maintenance work, check correct operation of the device(s). Check again the integrity of the device(s) and run a functional test.



WARNING: The safety device must always be maintained in efficient working conditions in conformity with the manufacturer's instructions.

REMEMBER! GAMMA SYSTEM devices maintain conformity to the original EC certification requirements only if **GAMMA SYSTEM** genuine parts are used when replacing or repairing damaged components..

Maintenance tasks must be performed by qualified, maintenance personnel only.

Periodically run a functional test and check the control device integrity in order to check correct and efficient operation..



WARNING: Any type of failure not immediately detectable must be reported to GAMMA SYSTEM..

DISPOSAL OF THE CONTROL UNIT/S

At the end of the GP04 T useful life, the device is considered a RAEE waste equipment (electric and electronic waste) which must be disposed of in conformity with the European environmental directives (RAEE 2012/19/UE).



These products must be disposed of in conformity with the European Directive 2012/19/UE.



DO NOT STACK the disassembled parts which must be disposed of.

Separate the waste and put product to be disposed of in proper containers in order to allow for their re-use, recycling or confinement of the hazardous substances.



Gamma System reserves the right to modify the characteristics of its products without any prior notice in order to improve their functionality and efficiency.

Gamma System S.r.l.

Via Torino, 24/i 10044 Pianezza (TO) Italy

Tel. +39.011.968.24.66 r.a. - Fax +38.011967.42.11

www.gammasystem.com